

SHARP®

MODEL
型號
Модель
VL-DC1E

OPERATION MANUAL

Please read this operation manual carefully
before using the VIEWCAM.

使用說明書

在使用本攝錄放影機之前，
請先閱讀本使用說明書。

Инструкция по эксплуатации

Пожалуйста, прочитайте внимательно эту
инструкцию по эксплуатации перед тем как
пользоваться видеочамерой.

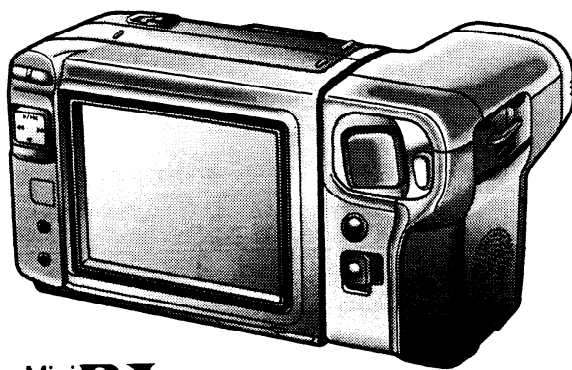

Mini **DV**

- The **Mini DV** logo is a trademark.
- **Mini DV** 標記是商標
- Буквы **Mini DV** являются торговой маркой.

SHARP



OPERATION MANUAL

ENGLISH

WARNING

TO PREVENT SHOCK HAZARD, DO NOT EXPOSE THIS APPLIANCE TO RAIN OR MOISTURE.

This equipment should be used with DC 3.6 V --- only or recommended AC adaptor.

CAUTION

To prevent electric shocks and fire hazards, do NOT use any other power source.

CAUTION

To prevent shock, do not open the cabinet. No user serviceable parts inside. Refer servicing to qualified dealer or service centre.

Important:

Audio-visual material may consist of copyrighted works which must not be recorded without the authority of the owner of the copyright. Please refer to relevant laws in your country.

Power supply:

This unit can be operated by connecting it to either the AC adaptor, battery pack, or optional car battery adaptor/battery charger. The AC adaptor incorporates the AUTO VOLTAGE (AC 110–240 V, 50/60 Hz) function.

Your VIEWCAM is designed to record in SP mode only. It will not perform normal playback for programmes prerecorded in LP mode.

NOTE

The VIEWCAM's LCD panel is a very high technology product with more than 112,000 thin-film transistors*, giving you fine picture detail. Occasionally, a pixel may appear on the screen as a fixed point of blue, green, red, or black. Please note that this does not affect your VIEWCAM's performance.

*Specifications are subject to change without notice.

Information for Australia/New Zealand Only

WARNING:

This Camcorder must be supplied with D.C. 3.6 volts only from a BT-L2 battery, the AC adaptor or the optional VR-410CH car battery adaptor/battery charger or the optional VR-410CA car battery adaptor.

CAUTION:

As there are no user-serviceable parts inside the Camcorder and AC adaptor, do NOT remove their cabinets as touching parts inside could result in electric shock. Please refer servicing to a qualified dealer or a Camcorder service centre approved by Sharp.

NOTE

This VIEWCAM is a high technology product. The LCD Panel comprises 112,320 TFT Transistors. Due to the high density of transistors, it is possible that some pixels may fail.

Important:

Copyright may exist in material you wish to record.

Copying such material without permission of the relevant licensees or owners of the copyright is prohibited by law.

Sharp is not in a position to authorize the recording of copyright works and nothing in this operation manual should be read or implied as giving that authority.

Contents

Important Information

Supplied Accessories	3
Optional Accessories	4
Precautions	5
About the DV (Digital VCR)	8
Mini DV Cassette	9
Part Names	11

Preparation

Installing the Memory Backup Battery	13
Installing the Battery in the Remote Control	13
Using the AC Adaptor/Battery Charger	14
Inserting and Removing the Battery Pack	15
Powering the VIEWCAM from an AC Outlet	16
Powering the VIEWCAM from Your Car Battery	17
Inserting and Removing a Mini DV Cassette	18
Controlling the Monitor Display	19
Using the On-screen Menu	20
Warning Indicators	22
Setting the Area, Date and Time	23
World Clock	24
Picture/Backlight Adjustments	27
Using the Hand Strap	28
Attaching the Shoulder Strap	28

Basic Operations Camera Recording

Easy Camera Recording with Full Auto	29
Zooming	30
Setting the Digital Zoom	30
Digital Quick Zoom (Extend Zoom)	31
Auto Focus	31
Backlight Compensation (BLC)	32
Gain-up (Cat's Eye)	32
Digital Image Stabilization (DIS)	33
Macro Shots	33
Fade In and Fade Out	34
Recording with the Wide Screen (16:9)	35
Quick Return	36
Edit Search	36
Tips on Recording Positions	37
Hints for Better Shooting	37
Setting the VIEWCAM to Full Auto Mode	38
Remaining Recording Time Display	39
Remaining Battery Power Display	39
Using the Infrared Remote Control	40

**Basic Operations
Playback**

Playback	41
Volume Control	41
Fast Forward and Rewind	41
Displaying the Date and Time of Recording	42
Video Search	42
Still	42
Slow	42
Frame Advance	43
Strobe Playback	43
Turning Off the LCD Monitor Backlight	43
Programme Search	44
Using the Time Code	45
Using the Tape Counter	46
Skip Playback	47

**Useful Features for
Camera Recording**

Self Recording	49
Manual Focus	52
Setting the Shutter Speed	53
White Balance Lock	54
Manual Iris	55
Strobe Recording	55
Recording a Five-second Still Image (Snapshot)	56
Still Recording	56
Lighting	57



**Connections and
Editing**

Using the A/V Pack	58
Connections for Playback on a TV with Audio/Video Jacks	58
Connection to TV without Audio/Video Jacks	59
Connection to TV via VCR	60
Watching Played-back Tapes on a TV	60
Editing	61

Others

Fluorescent Lamp Backlight	62
Before Requesting Service	63
Specifications	65
Easy Menu Reference Chart	66

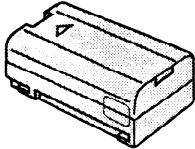
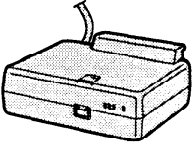
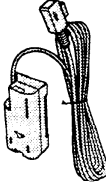
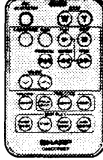
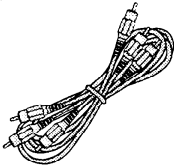
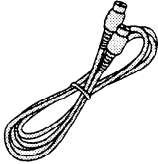
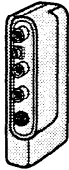
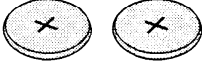
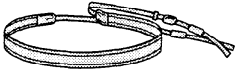
Supplied Accessories

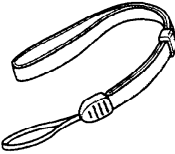
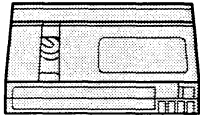
 <p>Battery pack BT-L2</p>	 <p>AC adaptor/battery charger</p>	 <p>DC output cable (2.0 m)</p>	 <p>Infrared remote control</p>
 <p>Audio/video cable (RCA type) (1.5 m)</p>	 <p>S-video cable (1.5 m)</p>	 <p>A/V pack</p>	 <p>Lithium battery × 2</p>
 <p>Shoulder strap</p>	 <p>Tripod adaptor</p>	 <p>Hand strap</p>	 <p>Mini DV video cassette</p>

Optional Accessories

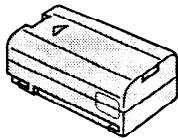
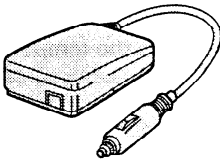
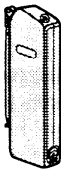
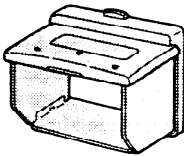
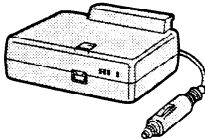
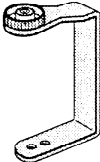
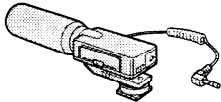
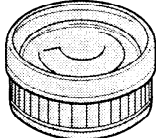
 <p>Battery pack BT-L2</p>	 <p>Car battery adaptor VR-410CA</p>	 <p>Tuner pack VR-HT31P</p>	 <p>Sun hood VR-39BF</p>
 <p>RF converter VR-H30RF or VR-X30RF</p>	 <p>Car battery adaptor/ battery charger VR-410CH</p>	 <p>Accessory shoe adaptor VR-30AD</p>	 <p>Tripod adaptor for 180° recording VR-33FA</p>
 <p>Stereo microphone VR-1MC</p>	 <p>Soft case VR-33SC</p>	 <p>Telephoto conversion lens VR-TC37</p>	 <p>Wide conversion lens VR-WC37</p>
 <p>Mini DV video cassette VR-DVM60N</p>	<p>Note:</p> <ul style="list-style-type: none"> • Some of these accessories may not be available in selected areas. 		

Precautions

Use & Care

- After operation, remove the battery pack from the unit.

- **Do not aim the lens at the sun.**

Do not allow direct sunlight to strike the VIEWCAM lens or LCD panel, whether recording is in progress or not, as it may damage the CCD sensor or LCD panel surface. Be particularly careful when recording outside.

- When shooting in dark places, avoid sudden brightly lit objects or light sources, such as the sun. Otherwise, the image may white out. Should this happen, point the camera in a different direction until the picture returns to normal.

- **Avoid magnetic sources.**

Using the VIEWCAM near strong fluorescent lights, motors, televisions, or other magnetic sources may adversely affect recorded images.

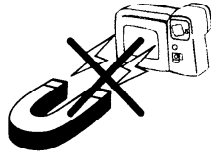

- **Remember to remove the cassette tape, turn off the power, and remove the battery pack when the VIEWCAM is not in use.**

- **Using the VIEWCAM near a broadcasting station or other powerful transmission source may cause buzzing or picture deterioration.**

- **Avoid shocks and dropping.**

Do not drop or otherwise subject the VIEWCAM to hard shocks or strong vibrations. Bumping or striking the unit during recording will generate noise in the recorded image.

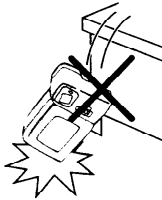

- **Avoid placing the VIEWCAM in close proximity to lighting equipment.**

The heat from incandescent lights may deform the VIEWCAM, or cause it to malfunction.

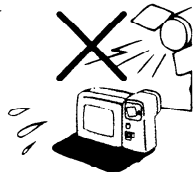

- **Always respect prohibitions or restrictions on the use of electronic equipment on commercial flights or in other sensitive areas.**

- **Watch the temperature and humidity.**

You can use your VIEWCAM at 0°C to +40°C and at 30% to 80% relative humidity. Do not store the unit in an unventilated car in the summer, in direct sunlight, or near strong heat sources; this can result in severe damage to the unit's casing and circuitry. Be careful when handling the unit after it has been left in a hot place, such as the ones described above.

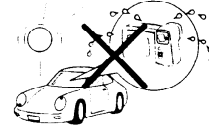

- **Avoid situations where water, sand, dust or other foreign matter could get on or inside the VIEWCAM. Such substances could cause malfunctions.**

Do not use your VIEWCAM in areas with excessive smoke or steam.

Do not leave your VIEWCAM in areas with excessive dust or moisture.

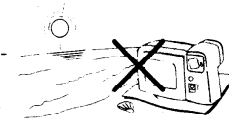

Such environments can cause mildew to form on this unit's lenses. Be sure to provide ample ventilation.

- **Some small, portable tripods may be difficult to attach and may not be sturdy enough to support your VIEWCAM. Be sure to use only a strong, stable tripod.**

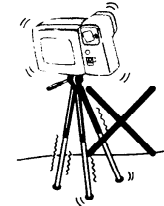

- **When using your VIEWCAM in a cold environment, the colour LCD view screen may appear less bright. This often occurs in cold environments immediately after the power is turned on. This is not a malfunction. If this occurs, put the VIEWCAM in a warmer location for some time before use. To prevent excessive cooling, wrap the VIEWCAM in a thick cloth (a blanket, etc.).**

Dew Formation

• What is "dew formation"?

When cold water is poured into a glass, dew drops form on the glass. This clinging of water drops is called dew formation.

• When dew forms in your VIEWCAM.

Dew will gradually form on the head drum of your VIEWCAM and make the video tape stick to the head. This causes damage both to the head and the tape. When dew formation occurs, recording and playback may not function properly.

Dew is likely to form in the following circumstances:

- when moving the VIEWCAM from a cold place to a warm place,
- when placing the VIEWCAM in a cold room which is then heated rapidly,
- when moving the VIEWCAM outdoors from an air conditioned room,
- when placing the VIEWCAM in the direct path of air blowing from an air conditioner,
- when placing the VIEWCAM in a humid room.

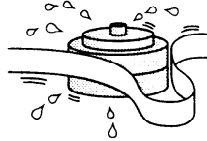

• How to prevent trouble due to dew formation.

When using the VIEWCAM in a place where dew formation is likely to occur, allow the VIEWCAM and the video tape to acclimate to the surroundings for about one hour. For example, when bringing the VIEWCAM indoors after skiing, place it in a plastic bag and allow it to adapt to room conditions for some period of time.

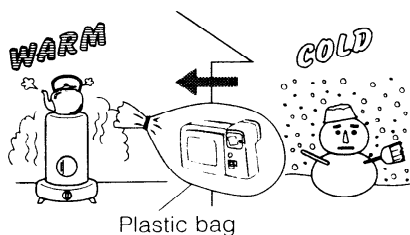

- 1 Be sure to tightly seal the plastic bag containing the VIEWCAM.
- 2 Remove the bag when the air temperature inside it reaches the temperature of the surroundings.

• "Dew" warning feature

If dew forms, the word "DEW" flashes on the LCD monitor, and the power will automatically turn off in approximately 10 seconds.

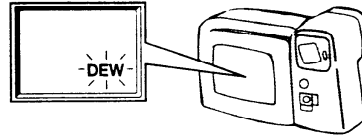

- 1 If the word "DEW" flashes on the LCD monitor, remove the cassette, leave the cassette compartment open, and wait several hours to allow the VIEWCAM to acclimate to the surrounding temperature.
- 2 To use the VIEWCAM again, turn on the power after waiting for several hours. Be sure that the word "DEW" has disappeared from the monitor screen.
- 3 Do not insert a cassette while the word "DEW" is flashing; this may result in damage to the tape.
- 4 Since dew forms gradually, it may take 10 to 15 minutes before the dew warning feature engages.

• How to continually maintain good recording.

If used in a variety of places, eventually your VIEWCAM may not function properly due to accumulation of dirt on the head drum. Please pay special attention to the following points when using your VIEWCAM.

- 1) Dew formation on the head drum.
- 2) Worn video tapes:
 - Using a damaged or soiled video tape may also soil the head drum, causing the picture to be blurred or nothing to be recorded on the video tape. Do not use such a video tape.
- 3) VIEWCAM use in a humid or dusty place. Use in extremely humid or dusty places may cause damage to your VIEWCAM.

• When the video heads become clogged.

Using the VIEWCAM when the video tape is dirty may cause the head to clog, producing noise on the recorded image or preventing the image from being recorded at all. Under such circumstances, contact the nearest SHARP service centre or your dealer for further advice.

(Video head cleaning can be done by using a commercially available cleaning tape. However, excessive use of the cleaning tape may also cause damage to the video heads. Please read the instructions accompanying the cleaning tape carefully, before using it.)

Precautions

Battery Pack

This VIEWCAM uses a lithium-ion type battery pack. It is not necessary to store the lithium-ion battery pack in a fully discharged state. Also, if stored in the charged state, the battery will gradually self-discharge, resulting in decreased recording time. Charge the battery pack soon (a day) before use.

Battery pack consumption

- Recording with many starts and stops, frequent zooming, and recording in low temperatures will somewhat shorten actual recording times. Accordingly, be sure to turn off the power when not recording. Use of an auxiliary battery pack is recommended to prevent undesirable interruptions in your recording.
- Do not use an insufficiently charged or weak battery pack. Such battery packs may cause the power to automatically stop during VIEWCAM operation to protect both the battery pack and the unit.

Battery power is consumed even when the VIEWCAM's power is turned off. If you are not going to use your VIEWCAM immediately, remove the battery pack. (See page 15.)



Note:

- Use only the SHARP BT-L2 battery pack. It is designed specifically for use with this VIEWCAM.

How to use the marker on the battery pack

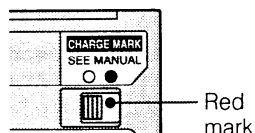
The marker is provided to indicate the battery's charge condition. Slide the switch to indicate the charge condition as shown below.



Position	Charge condition
	Before charging
	After charging

Temperature during charging

- Store the battery pack in a dry, cool place.
- Charge the battery pack at temperature of 10°C to 30°C.

For long battery lifetime

- Charge the battery pack (lithium-ion type) at least once every six months.
- Do not leave the battery pack being charged for long periods of time.

Cautions:

- If the battery pack is misused, there is danger of fire or explosion. Pay close attention to the following:
 1. Do not dispose of in fire.
 2. Do not allow metallic objects to come in contact with the terminals. This can cause a short circuit.
 3. Do not disassemble or repair by yourself.
 4. Do not use any battery charger other than those designed for use with these battery packs.
 5. Do not place the battery pack under direct sunlight or in excessively hot places (over 60°C) such as the dashboard of cars.
 6. Do not expose to moisture, water, or salt water.
 7. Do not drop or subject to strong force.
 8. Keep battery out of reach of children and in the original package until ready to use.
 9. Dispose of used batteries promptly.
- The battery pack will become warm during charging and use. This is normal and not a malfunction.
- The battery pack has a limited service life. If the period of use becomes noticeably shorter with a normal charge, the battery pack is at the end of its service life. Replace it with a new battery pack.
- For safety, keep the battery pack in its protective cover when it is not being used. If the metal parts of the battery pack come in contact with other metal objects, there is a danger that a short circuit may occur.

About the DV (Digital VCR)

The "DV" trademark can only be used on digital VCR products which have been evaluated and have met the specifications set by the **HD Digital VCR Conference for Standardization of Consumer Use Digital VCR Formats**.

1. High horizontal resolution

Detailed, accurate images with the highest level of horizontal resolution for home use.

2. Clear colour reproduction with virtually no colour contamination

Provides three times the colour resolution of conventional VCRs (based on Sharp models). Clear images with virtually no distracting colour contamination (which usually appears as red).

3. Standard use of TBC (time base collector) to prevent jittery images

Ensures stable images with a high signal-to-noise ratio.

4. PCM digital recording

PCM digital recording gives you high-quality stereo sound that puts you in the middle of the action.

DV digital VCR tapes

There are two kinds of DV digital VCR tapes: the Mini DV cassette and the larger DV cassette used for extended playback and recording. This VIEWCAM only operates with Mini DV cassettes. DV cassettes cannot be used. Be sure to use Mini DV cassettes with the **Mini DV** mark.

Mini DV cassette



DV cassette

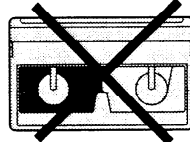

DV digital technology and conventional VCRs

- 8 mm, VHS, or Beta cassettes cannot be used for playback or recording with this unit.

8 mm cassette



VHS cassette



Beta cassette

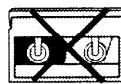

- An 8 mm, VHS, or Beta VCR (or camcorder) can be connected using the A/V pack, and the A/V cable or S-video cable.

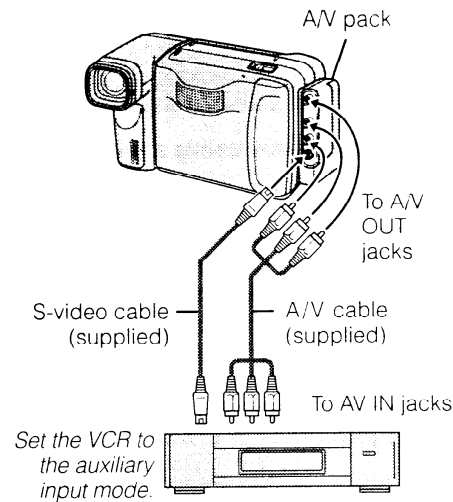

- **Audio and video cannot be input to this VIEWCAM.**

- You can also watch tapes by connecting to a conventional TV.

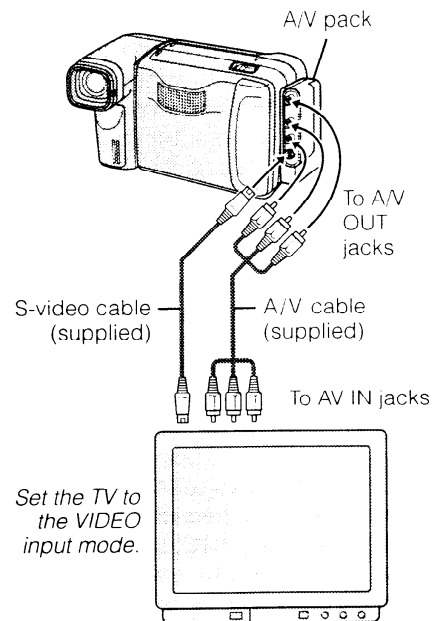

Note:

- This VIEWCAM reproduces the highest picture quality when used with an ME tape. We recommend you use an ME tape for high-quality recording and playback.

Precautions

Mini DV Cassette

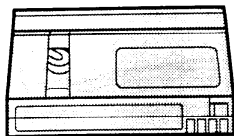

Precautions when using a Mini DV cassette

- Be sure to use only Mini DV cassettes with the **Mini DV** mark.
- This VIEWCAM can record and play back with Mini DV cassettes with cassette memory, but it cannot record or play back this memory.
- 8 mm, VHS, or Beta cassettes cannot be used for playback or recording with this unit.

8 mm cassette VHS cassette Beta cassette



- Do not insert anything into the holes on the bottom of the Mini DV cassette or block them in any way.
- Avoid placing the cassette in an area conducive to dust or mold.
- Do not place the cassette near magnetic sources such as electric clocks or magnetic devices as this may adversely affect recorded material.
- When a previously recorded Mini DV cassette is used again for recording, the previously recorded material will be automatically erased.
- The Mini DV cassette will not operate if inserted on the wrong side.
- Do not repeatedly insert and eject the Mini DV cassette without running the tape as this may cause uneven tape winding and damage the tape.
- Do not place the cassette in direct sunlight, near strong heat sources, or in areas with excessive steam.
- Store the cassette in its case and stand it in an upright position.
- If the tape is not properly wound, rewind the tape.
- Do not drop the cassette or subject it to excessive shocks.

E 9

To protect recordings against accidental erasure

Slide the protect tab on the rear of the Mini DV cassette to the "SAVE" position.

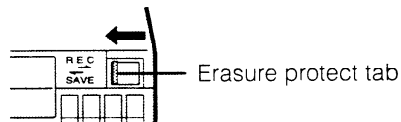

To record over a previously recorded tape, slide the protect tab to the "REC" position.

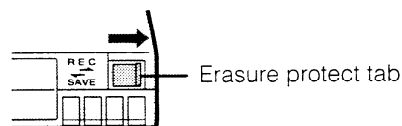

Copyright protection

- The digital VCR has far superior recording and playback ability than the traditional analog VCR, and in order to protect digital video software copyrights, a system for managing copyrights has been established. Some digital video software may have pre-recorded copyright protection signals and cannot be played back on this VIEWCAM. When playing back a copyright-protected tape, the "COPYRIGHT PROTECTED." warning will be displayed on the monitor screen. Copyright protection signals cannot be recorded with this VIEWCAM.

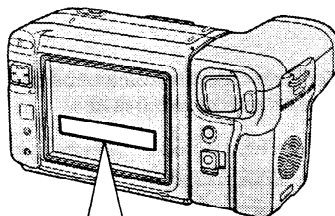

COPYRIGHT PROTECTED.

Care

Cleaning and maintenance

- Many plastic parts are used in the VIEWCAM casing. Do not use thinners, benzenes or other strong chemical cleaners. These may cause discoloration and damage to the casing.
- Clean the casing with a soft, dry cloth. If the casing is particularly dirty, wipe the casing with a tightly wrung cloth dampened with a diluted, neutral detergent. Then wipe it again with a soft, dry cloth.
- Use a cloth to wipe finger marks and other soiling off the LCD monitor and lens protector.
- If the lens needs cleaning, first remove the lens protector by turning it anticlockwise. Then clean the lens with a cloth, or compressed air and lens papers designed for photographic lenses.

Using Your VIEWCAM Abroad

Television system signals and electrical system voltages and frequencies vary substantially from country to country. When you are abroad, please check the sections below before using the AC adaptor or connecting the VIEWCAM to a TV.

AC Power Sources

The AC adaptor is compatible with 50 Hz and 60 Hz electrical systems in the range of 110 V to 240 V AC.

Car Cigarette Lighter Power Adaptor (Optional Accessory)

This can be used with 12 V and 24 V negative-ground cars only. Do not use it with positive-ground electrical systems.

Television Signal Systems

In any country, you can always watch the video picture by using the LCD monitor screen. However, if you want to watch the picture on a TV screen, the TV must be PAL system compatible. PAL is used in the following countries:

Germany, Great Britain, Sweden, Denmark, Austria, Belgium, Switzerland, Italy, Spain, Holland, Finland, Portugal, Norway, Hong Kong, Thailand, Australia, New Zealand, Singapore, Kuwait, China, etc.

Note:

To connect the VIEWCAM to a TV which does not have audio/video jacks, you must use the supplied A/V pack and the optional VR-H30RF or VR-X30RF RF converter (see page 59).

Part Names

For details on the use of each control, refer to the page number indicated in the brackets.

Front view

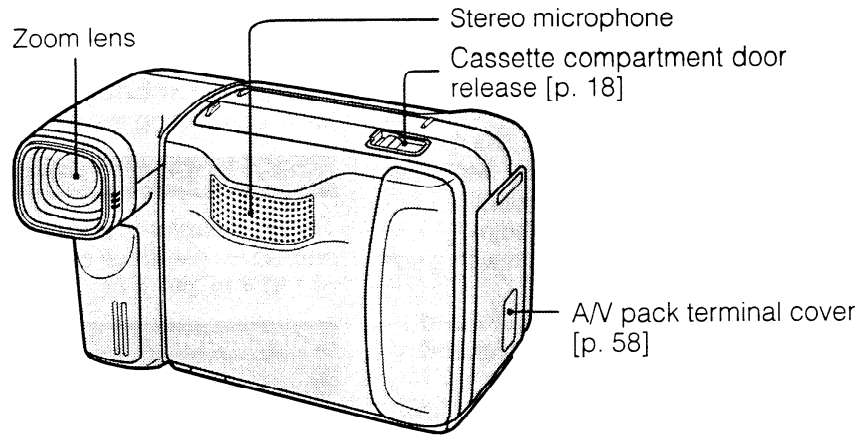

When the cassette compartment door is opened

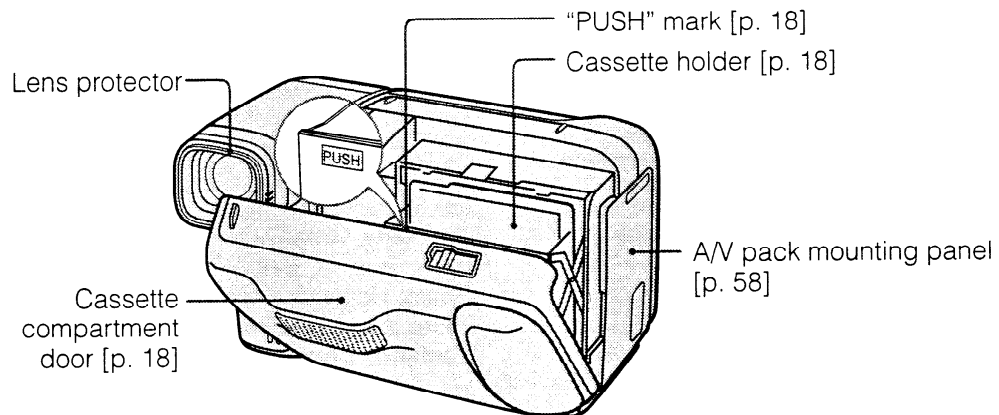

Removing the Lens Protector

Before mounting the optional wide or telephoto conversion lens, remove the lens protector by turning it anticlockwise.

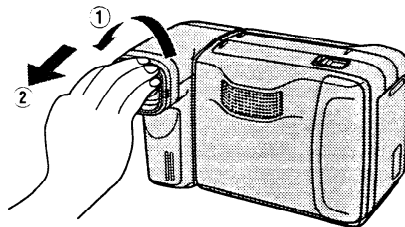

Rear view

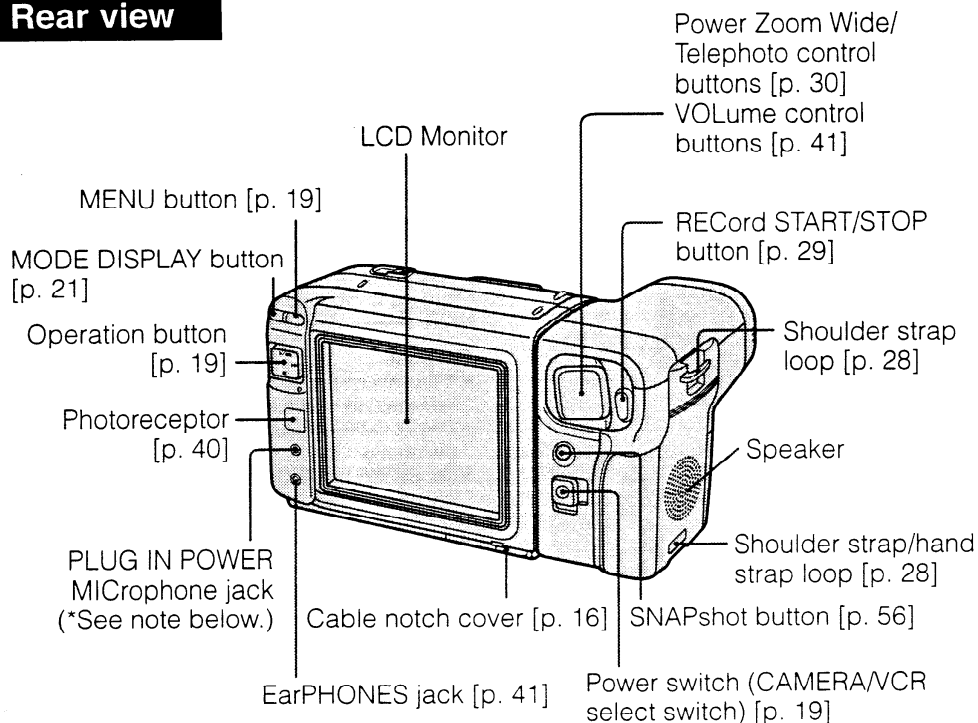

*About the PLUG IN POWER MIC Jack

This external microphone jack outputs a DC voltage of 4.0 V. It is for use with the microphone supplied with the sports case optional accessory for this VIEWCAM, or with any 2.5–4.0 volt DC use condenser-type microphone with a 3.5 mm diameter plug. The use of other types of microphones may result in damage to the microphone or the VIEWCAM.

Side view

When camera module is rotated

Fluorescent lamp compartment [p. 62]

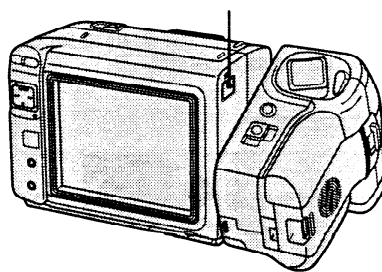

Bottom view

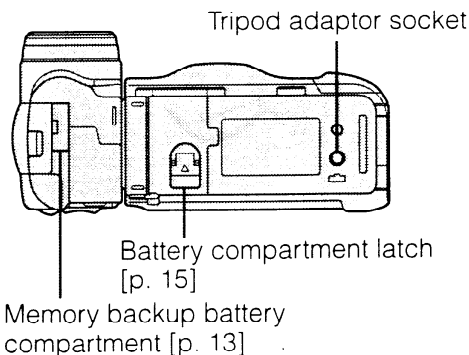

Preparation

Installing the Memory Backup Battery

Preparation

- 1 Pull out the battery holder from the memory backup battery compartment on the bottom of the VIEWCAM, using a pointed object such as the point of a pen.

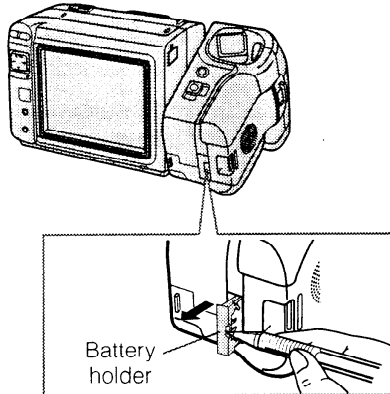

- 2 Insert the supplied lithium battery into the holder with the + side facing outward.

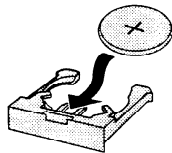

- 3 Insert the battery holder back into its compartment and push it in completely.

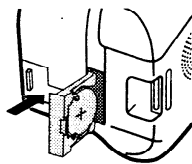

CAUTION: Danger of explosion if battery is incorrectly replaced. Replace only with the same or equivalent type CR2025 recommended by the equipment manufacturer.

WARNING: KEEP THIS BATTERY AWAY FROM CHILDREN. IF SWALLOWED, CONSULT A PHYSICIAN IMMEDIATELY FOR EMERGENCY TREATMENT.

CAUTION: BATTERY MAY EXPLODE IF MISUSED OR INSTALLED WITH POLARITY REVERSED. DO NOT RECHARGE, DISASSEMBLE OR DISPOSE OF IN FIRE.

Cautions:

- If the lithium battery is installed with polarity reversed, the backup function will fail.
- Do not short-circuit, recharge, disassemble, or heat the battery.
- Should the battery leak, wipe the battery compartment clean, and then insert a new battery.

Notes:

- The lithium battery is used to back up the calendar and other memory functions.
- The battery will last about one year of normal usage.
- Replace the battery with a new CR2025 cell when the VIEWCAM's time indicator starts to fall behind the correct time.

Installing the Battery in the Remote Control

- 1 Hold the remote control facing down, then pull out the battery holder while pressing the tab toward the centre.

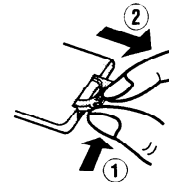

- 2 Install the supplied CR2025 lithium battery with its + side matching the ⊕ marked side of the battery holder.

- 3 Insert the holder in the direction of the arrow. Make sure that the ⊕ side faces the back of the remote control.

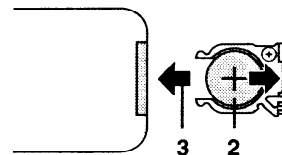

Using the AC Adaptor/Battery Charger

Precautions:

- If used near a radio, the AC adaptor/battery charger may interfere with reception.
- Prevent flammables, liquids, and metal objects from entering the unit.
- This is a sealed unit. Do not attempt to open or modify it.
- Do not damage, drop, or subject the unit to vibration.
- Do not leave the unit in direct sunlight.
- Avoid using the unit in humid or extremely hot places.
- If the power source becomes disconnected during recording, playback, or other operations, the tape will remain wrapped around the drum and may be damaged. Reconnect the power source to the main unit immediately.
- The supplied AC adaptor/battery charger is specially designed for use with the VIEWCAM, and should not be used as a power supply for other camcorders.

Charging the Battery Pack

- 1 Be sure the DC output cable is disconnected from the AC adaptor/battery charger, then insert the AC plug into a power outlet. The POWER indicator will light up.

To power outlet

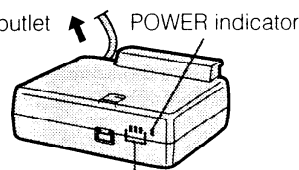

CHARGE indicators

- 2 Align the ▼ mark on the battery with the ▲ mark on the charger (1), then guide the battery into the groove. Pressing the battery (2), slide it in the direction of the arrow (3) until it locks into place.

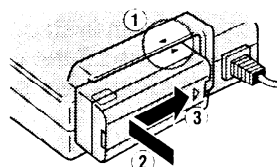

- 3 When the battery is charged, all three CHARGE indicators will light up. Remove the battery and the AC plug.

CHARGE indicators

	Charging starts. (Indicator starts flashing.)
	Now charging.
	Charging completed. (The indicators will turn off approximately 90 to 120 minutes after charging is completed.)

Charging time using AC adaptor/battery charger and maximum time for continuous camera recording and playback

Battery pack	Charging time	Max. Recording Time	Max. Playback Time
BT-L2	Approx. 90 min.	Approx. 50 min.	Approx. 50 min.

Notes:

- The above playback time is based on operation of the VIEWCAM without use of the A/V pack and with the volume set at the middle setting.
- The battery and charger warm up during charging. This is not a malfunction.
- Charging time depends on the ambient temperature and the condition of the battery.

Cautions:

- Charge only SHARP model BT-L2 battery pack. Other types of batteries may burst, causing personal injury and damage.
- Do not incinerate or mutilate the battery pack. It may present the risk of a rise in surface temperature, and/or the release of flammable vapors.
- Replace battery with BT-L2 only. Use of another battery may present a risk of fire or explosion.

Preparation

Inserting and Removing the Battery Pack

Preparation

Inserting the Battery Pack

- 1 Raise the battery compartment latch on the bottom of the VIEWCAM (1), turn it anticlockwise (2) and open the compartment door (3).

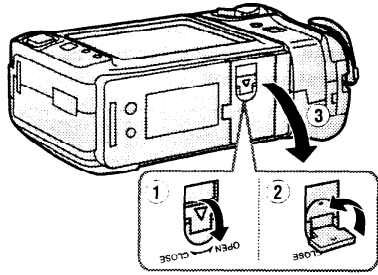

- 2 Insert the battery pack into the compartment, as shown, and push it in completely.

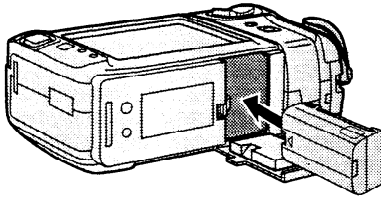

- 3 Close the door (1), turn the latch clockwise to secure it firmly (2), and then push down the latch (3).

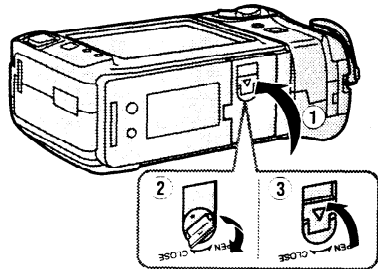

Removing the Battery Pack

Perform step 1 above, then, with the VIEWCAM facing down, press the battery release (1) and remove the battery (2).

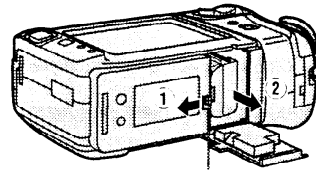

Battery release

Cautions:

- BEFORE REMOVING THE BATTERY PACK, ALWAYS STOP THE TAPE AND TURN THE POWER OFF. If you remove the battery pack during recording or playback, the tape will remain wound around the video head drum and may be damaged. Should the power source (battery or adaptor) become disconnected during operation, reconnect it again immediately.
- Do not expose the battery compartment door to strong force, as it may come off.
- Be sure to close the battery compartment door firmly, especially during operations. If you do not, the battery pack may come off or VIEWCAM operation may fail because of the poor contact pressure.
- Remove the battery pack from the VIEWCAM or disconnect the VIEWCAM from the AC adaptor if the VIEWCAM will not be used for a long time.
- When removing the battery pack, do not tilt the VIEWCAM so that the battery compartment faces down. The battery pack may fall out.

Battery Pack Handling

- Make sure that you take enough battery packs with you to provide two to three times your estimated recording time. See page 29.
- Recording time will be reduced in cold weather.
- The battery will drain in Recording Standby mode. Turn off the power if you will not be recording again soon.

Powering the VIEWCAM from an AC Outlet

- 1 Slide the cable notch cover in the direction of the arrow.

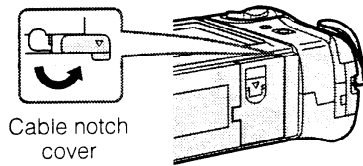

- 2 Raise the battery compartment latch on the bottom of the VIEWCAM (1), turn it anticlockwise (2) and open the compartment door (3).

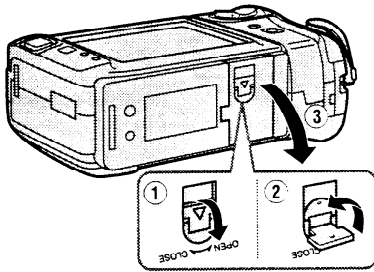

- 3 Insert the DC cable connecting plate into the compartment and push it in until it clicks (1). Pass the cable through the cable notch (2), and close the door (3). Turn the latch clockwise to lock the door, and push down the latch (4).

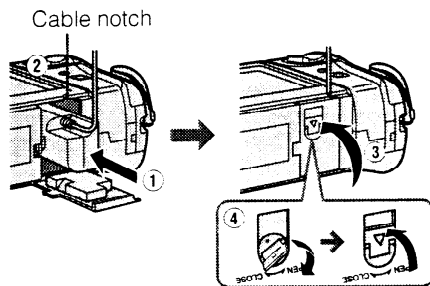

- 4 Insert the DC cable plug into the DC OUT jack on the AC adaptor (1), then plug the power cord into a power outlet (2). The POWER indicator on the AC adaptor will light up.

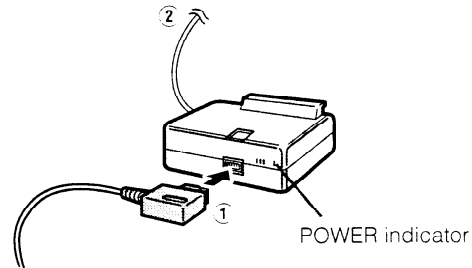

Removing the DC Cable from the VIEWCAM

- 1 Perform steps 1 and 2 above.
- 2 Remove the cable from the notch (1), press the release as shown (2), and remove the connecting plate from the compartment (3).

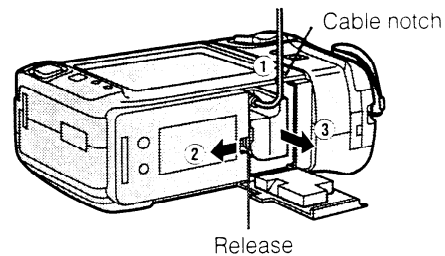

Cautions:

- Turn the Power switch off before removing the DC cable.
- When removing the DC cable, grasp the connecting plate, not the cable itself, and pull it out of the compartment.
- When removing the connecting plate, do not tilt the VIEWCAM so that the battery compartment faces down. The connecting plate may fall out.

Note:

- After removing the DC cable, return the cable notch cover to the former position.

Preparation

Powering the VIEWCAM from Your Car Battery

Preparation

Use the optional VR-410CH car battery adaptor/battery charger (or the VR-410CA car battery adaptor) when you want to power the VIEWCAM from the battery of your car while it is idling or being driven.

- 1 Slide the cable notch cover in the direction of the arrow.

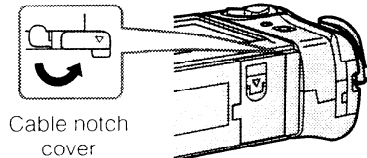

- 2 Raise the battery compartment latch on the bottom of the VIEWCAM (1), turn it anticlockwise (2) and open the compartment door (3).

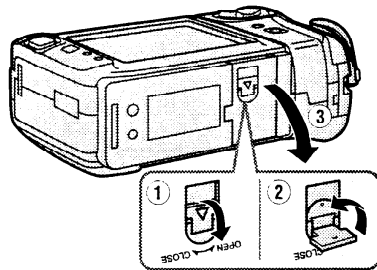

- 3 Insert the DC cable connecting plate into the compartment and push it in until it clicks (1). Pass the cable through the cable notch (2), and close the door (3). Turn the latch clockwise to lock the door, and push down the latch (4).

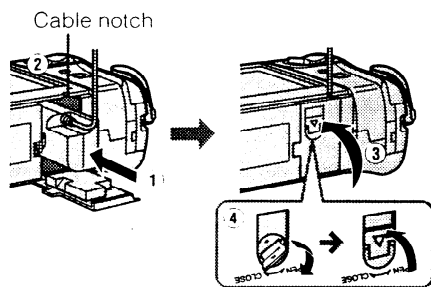

- 4 Insert the DC cable plug into the DC OUT jack on the VR-410CH (or VR-410CA).

- 5 Start the car engine and leave it idling, then insert the power cord plug of the car battery adaptor into the cigarette lighter socket. (The POWER indicator on the VR-410CH will light up.)

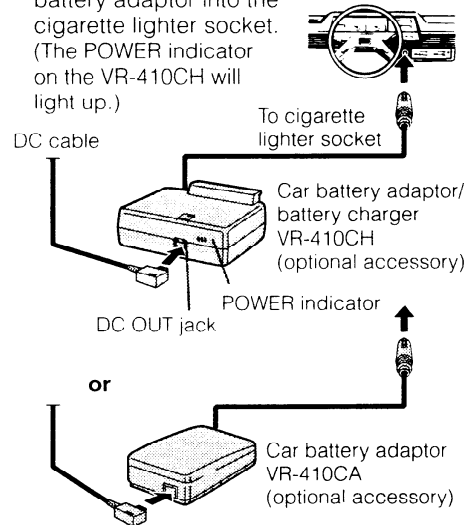

Notes:

- See the VR-410CH (or VR-410CA) operation manual for details.
- You can recharge the battery pack by using the VR-410CH in basically the same manner as the supplied AC adaptor/battery charger (see page 14).
- The VR-410CA cannot be used to recharge battery packs.

Cautions:

- Use in only DC 12 V or 24 V negative ground system cars. Positive-ground car batteries CANNOT BE USED. Check your car operation manual or consult a local car dealer.
- Use the VR-410CH (or VR-410CA) only when the car is idling or being driven. Otherwise, the car's battery will be drained.
- Charge only SHARP model BT-L2 battery pack. Other types of batteries may burst, causing personal injury and damage.
- Before starting the car engine, the VR-410CH (or VR-410CA) must be unplugged from the cigarette lighter socket.
- Before removing either the DC plug or the cigarette lighter plug, the VIEWCAM's Power switch should be set to OFF.
- Do not apply strong force to the DC cable connected to the VIEWCAM as this will cause a malfunction.
- The battery used in this device may present the risk of a rise in surface temperature and/or the release of flammable vapors. Do not incinerate or mutilate. Replace battery with BT-L2 only. Use of another battery may present a risk of fire or explosion.

Inserting and Removing a Mini DV Cassette

Inserting a Cassette

- 1 While holding down the Lock button, set the Power switch to CAMERA or VCR.

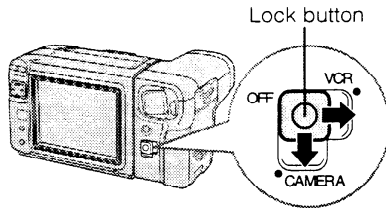

- 2 Slide the release and open the cassette compartment door.
 - The cassette holder automatically opens after about 10 seconds.

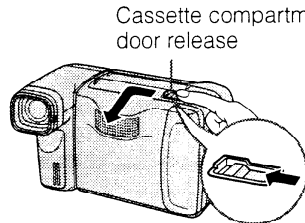

- 3 Insert the tape cassette fully with the window facing outwards, and with the erasure protect tab facing upwards.

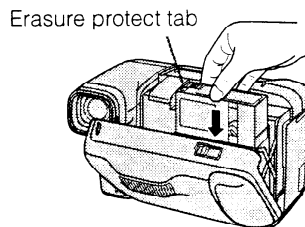

- 4 Press the "PUSH" mark gently until the cassette holder clicks into place.

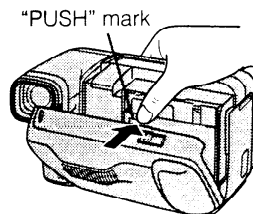

- 5 Close the compartment door pressing its centre until it clicks into place.

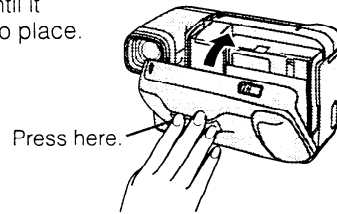

Preparation

Removing a Cassette

Perform steps 1 and 2 above, then take out the cassette.

Cautions:

- Be careful not to get your fingers caught in the cassette compartment.
- Do not apply force to the cassette compartment except for pressing the "PUSH" mark to close it.
- Do not tilt the VIEWCAM or hold it upside down when you are inserting or removing a cassette. It may damage the tape.
- Remove the cassette if you will not use the VIEWCAM for a long time.
- If you do not press the cassette holder closed correctly in step 4 above, the VIEWCAM's cassette protection mechanism might eject the cassette. If this happens, repeat the insertion procedure.
- Do not attempt to pick up the VIEWCAM by the cassette compartment door.
- If the compartment door does not close when gently pressed into position, check the compartment door release. The door release may not be completely opened as shown below on the left. In this case, slide the door release in the direction of the arrow and press the compartment door closed.

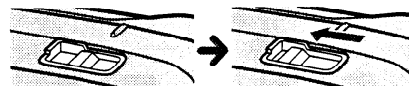

- If the battery power is too low, you may not be able to eject the cassette or operate the Power switch. Replace the battery pack with a fully charged one.

Preparation

Controlling the Monitor Display

You can use various functions and make mode settings while viewing the monitor display.

Preparation

MODE DISPLAY button

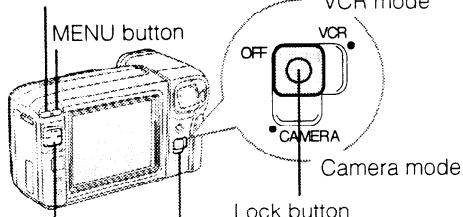

Operation button

Power switch

Lock button

- Hold down the Lock button when setting the Power switch to CAMERA or VCR.

Notes:

- The monitor illustrations in this operation manual are for the purpose of explaining the functions of the VIEWCAM, and may differ from the actual monitor displays.
- The displays below are those when a cassette is loaded in the VIEWCAM and the power is supplied from a battery pack.

Camera mode (when the Power switch is set to CAMERA)

- Each time you press the MENU button, the function screen display changes from 14 to 44.
- With the 44 screen displayed, press \blacktriangleright on the Operation button () to select "MENU". Each time you press \blacktriangleleft or \blacktriangleright on the button, the screen changes from MENU-PAGE 1 to 4.
- If the area, date and time have not been set, MENU-PAGE 4 appears when you press \blacktriangleright on the button to select "MENU" on the 44 screen (see page 23).

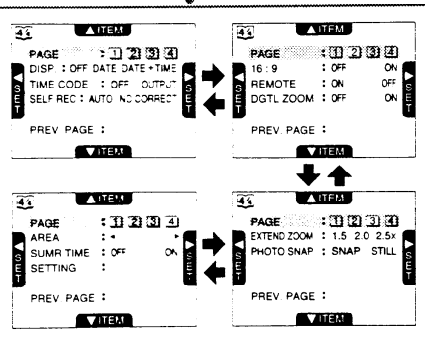
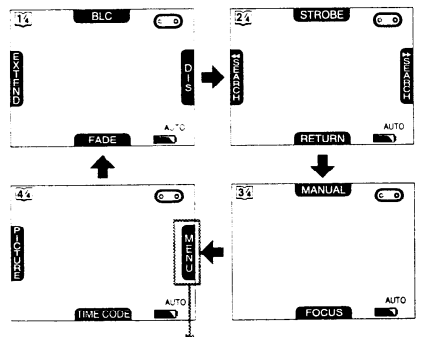

VCR mode (when the Power switch is set to VCR)

- Each time you press the MENU button, the function screen display changes from 14 to 34.
- With the 34 screen displayed, press \blacktriangleright on the button to select "MENU". The menu screen will appear.

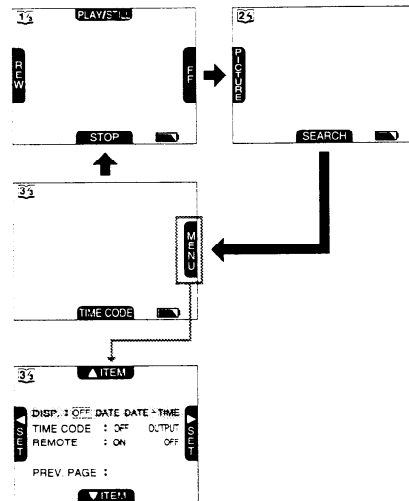

About the Operation button ()

Press up ($\blacktriangleright/\blacktriangleleft$), down (\blacksquare), left (\blacktriangleleft), or right (\blacktriangleright) to select one of the blue function items displayed on the edge of the screen.

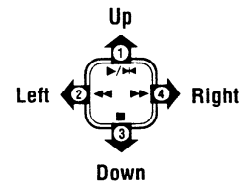

Note:

- The \blacktriangleright , \blacktriangleleft , \blacksquare , \blacktriangleleft , or \blacktriangleright buttons on the remote control cannot be used to move the cursor, or select or set any of the various functions on the monitor.

Using the On-screen Menu

In Camera mode

1 To display the Camera mode menu screen:

Hold down the Lock button and slide the Power switch to CAMERA. Then perform steps 2-4.

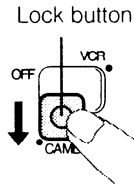

2 Press the MENU button until 4/4 screen appears on the monitor.

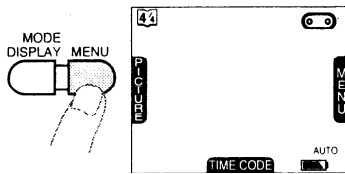

3 Press >>> on the Operation button () to select "MENU". MENU-PAGE 1/1 will appear on the monitor.

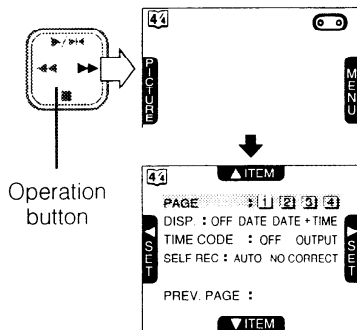

Note:

- If the area, date and time have not been set, MENU-PAGE 4/1 appears first. Refer to page 23 to set them.

4 Press left (<<<) or right (>>>) edge on the Operation button () to change from MENU-PAGE 1/1 to 4/4.

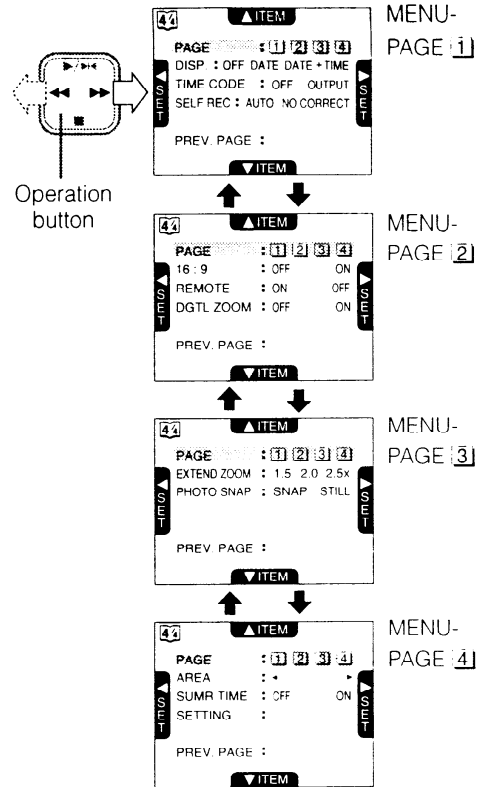

5 Press top (>/<) or bottom (■) edge on the button to select the menu item highlighted in light blue colour.

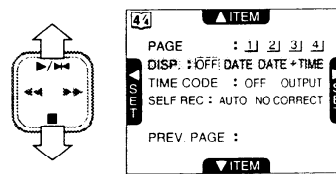

6 Press <<< or >>> on the button to set the desired mode.

- Each time you press the button, the item setting changes as shown below.

7 After completing the setting, press the MENU button. The menu screen will disappear.

Preparation

In VCR mode

Preparation

- To display the VCR mode menu screen:**
Hold down the Lock button and slide the Power switch to VCR. Then perform steps 2 and 3.

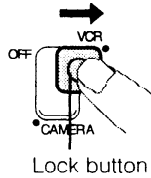

- Press the MENU button until **3/3** screen appears on the monitor.

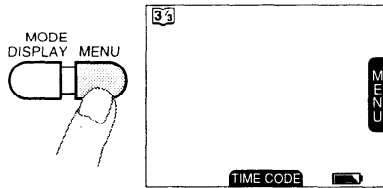

- Press **▶▶** on the Operation button (◻) to select "MENU". The menu display will appear on the monitor.

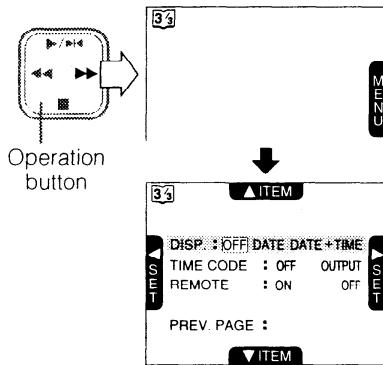

- After completing the setting, press the MENU button. The menu screen will disappear.

Notes:

- Certain menu items are common to both the Camera and VCR modes. If the "REMOTE" menu item, for example, is set to "OFF" in the Camera mode, it will automatically be set to "OFF" in the VCR mode.
- The menu screen cannot be displayed when the VIEWCAM is recording.
- To turn off the menu display, press the MENU button or MODE DISPLAY button. When the MENU button is pressed, the menu screen will disappear and the **1/1** screen will be displayed. When the MODE DISPLAY button is pressed, operation indicators will disappear. Press it again to display the indicators.

Returning to the Previous Screen





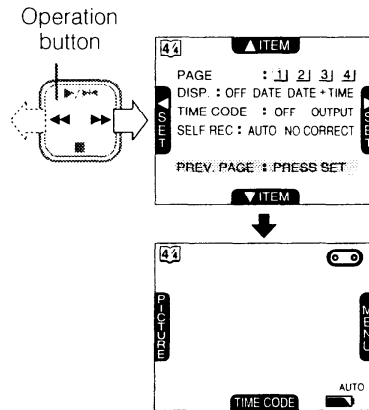

Press **■** on the Operation button (◻) to select "PREV. PAGE" and then press **◀◀** or **▶▶** to select "SET" to return to the previous screen.

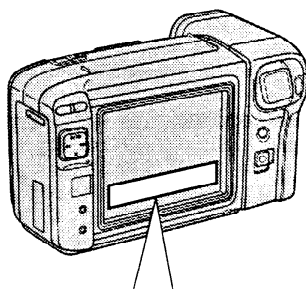
Ex. Camera mode



Warning Indicators



Display for the first 3 seconds	Display after the first 3 seconds	Description of warning
EJECT THE CASSETTE.	EJECT THE CASSETTE.	The video cassette is defective and should be removed.
DEW	DEW	Dew has formed inside the VIEWCAM. Wait for a few hours until the dew disappears (see page 6). About 10 seconds after this warning appears, the VIEWCAM turns off, and the display goes off too.
BATTERY IS TOO LOW.		The battery is almost depleted. Note: Operation of the zoom may interrupt the VIEWCAM power. Replace the battery pack.
		The video heads are clogged and should be cleaned (see page 6).
INSERT A CASSETTE.	CASSETTE	There is no tape cassette in the VIEWCAM. Load a cassette.
CASSETTE NOT RECORDABLE.	PROTECT. TAB	The red erasure protect tab in the video cassette has been slid to the record-protect position, preventing recording.
THE TAPE ENDS SOON.		The tape is about to end. Get ready to load a new cassette.
CHANGE THE CASSETTE.	TAPE END	The tape has reached its end. Load a new cassette.
REPLACE THE LAMP.	REPLACE THE LAMP.	The fluorescent lamp behind the LCD monitor is close to the end of its service life. Replace it with a new one (see page 62). The LCD monitor turns off about 1 minute after this warning is displayed.
		During Self Recording mode, every warning indicator is replaced by a "◇" indicator displayed in the centre of the monitor. To check the meaning of the warning, rotate the monitor back to the normal position.

Note:

•  indicates a blinking display.

Preparation

Setting the Area, Date and Time

Preparation

Example:

Setting the date to 2 June 1997 (2.6.1997) and the time to 10:30 am (10:30) in Hong Kong.

Notes:

- Check that the memory backup lithium battery has been installed before setting the date and time.
- The date and time, once set, are stored in memory.

- 1 Set the Power switch to CAMERA, then press the MENU button until 44 appears on the monitor (Camera mode).

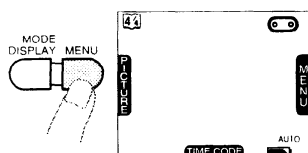

- 2 Press ► on the Operation button (E) to select "MENU". The MENU-PAGE 44 appears.

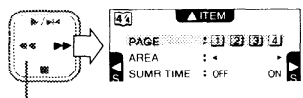

Operation button

- If the date and time have been set, the MENU-PAGE 11 appears. Press ► on the E button to select PAGE 4.

- 3 Move the light blue highlighted bar to "AREA" by pressing the ■ on the Operation button (1), then press ◀ or ▶ until "9 HNGKNG" (Hong Kong) appears (2).

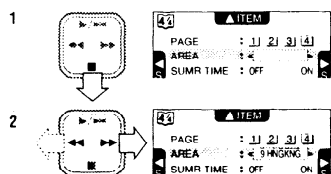

- See the time zone chart on page 25 and the area table on page 26 for area numbers and representative cities for each time zone.

- 4 Press ■ on the E button to select "SETTING" (1), then press ► to select "SET" (2).

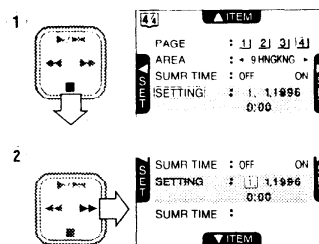

- 5 Press ►/◀ or ■ on the E button to select "2." (day), and press ►.

SETTING : 2. 1 1996
0:00

- 6 Press ►/◀ or ■ on the E button to select "6." (month), and press ►.

SETTING : 2. 6 1996
0:00

- 7 Press ►/◀ or ■ on the E button to select "1997" (year), and press ►.

SETTING : 2. 6 1997
0:00

- 8 Press ►/◀ or ■ on the E button to select "10" (hour), and press ►.

SETTING : 2. 6 1997
10:00

- 9 Press ►/◀ or ■ on the E button to select "30" (minutes), and press ►.

SETTING : 2. 6 1997
10:30

The date and time settings are now complete.

To Turn Off the Menu Display

Press the MENU button.

Notes:

- The internal clock starts operating when ► on the E button is pressed in step 9 above.
- When the tape cassette is inside, if no settings are made within 5 minutes after the menu display appears, the display is automatically cancelled.

World Clock

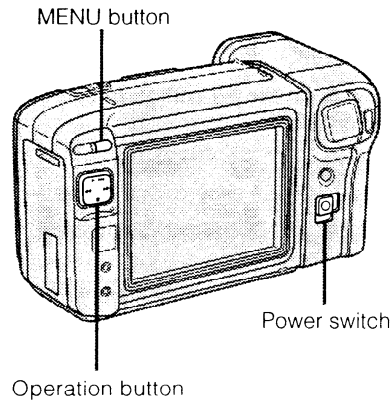

This VIEWCAM is equipped with a world clock feature. It allows you to easily adjust the time when you use the VIEWCAM while travelling anywhere in the world outside your home time zone. Set the area, date and time if they are not already set. (See page 23.)







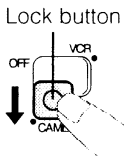

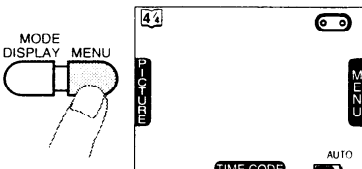
Changing the Area of the Time Zone

Example:

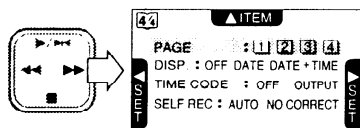
Changing the area from Hong Kong to Bangkok.

- 1 Hold down the Lock button and slide the Power switch to CAMERA.
 
- 2 Press the MENU button until  appears on the monitor.
 

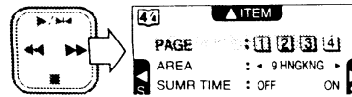

- 3 Press  on the Operation button () to select "MENU".
 

- 4 Press  on the  button to select PAGE .

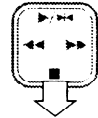

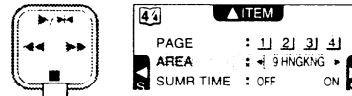

- 5 Press  to select "AREA".
 

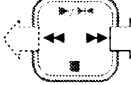

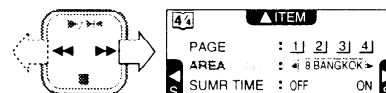
- 6 Press  or  until "8 BANGKOK" appears. The VIEWCAM is now set to the Bangkok time. Press the MENU button to turn off the menu.
 



Blank Area Setting

If you do not want to set the area (time zone), you can leave the setting blank. In step 6 above, press  or  on the  button until the area setting is blank (after "24").

To turn off the menu display

Press the MENU button.

Preparation

Preparation

To Display Area, Date and Time on the Monitor

- 1 Refer to page 20 to display function screen **44** and select MENU-PAGE **1**.
- 2 Press **■** on the Operation button (**E**) to select "DISP."

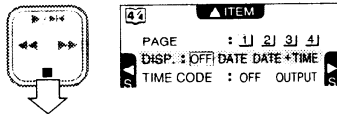

- 3 Press **←** or **→** on the **E** button to select "DATE" or "DATE+TIME".

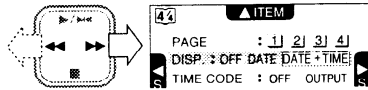

- 4 Press the MENU button to turn off the menu display. The area, date and time will be displayed on the monitor.

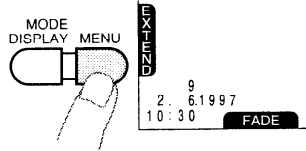

Setting Summer Time (Daylight Saving Time)

- 1 Refer to page 20 to display function screen **44** and select MENU-PAGE **1**. Press **▶** on the Operation button (**E**) to select MENU-PAGE **4**.

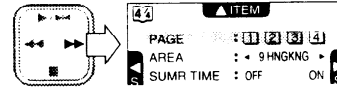

- 2 Press **■** on the **E** button to select "SUMR TIME".

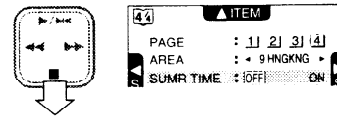

- 3 Press **▶** to select "ON". The time automatically changes to summer time.

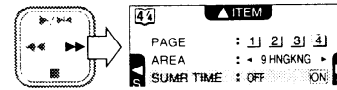

- 4 Press the MENU button to turn off the menu display. The "♦" mark will be displayed to the left of the area indicator. To reset to standard time, set the "SUMR TIME" menu item to "OFF".

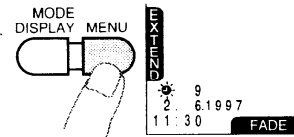

Time Zone Chart

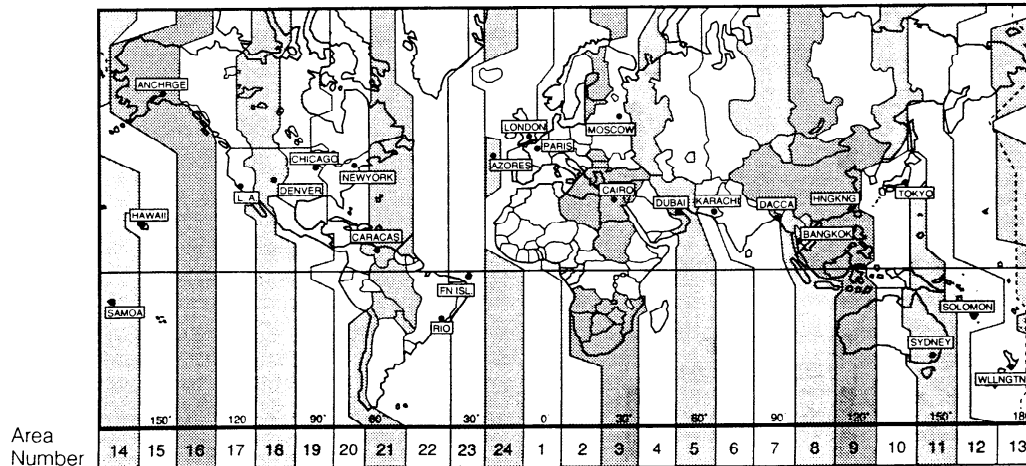

Area Table

Area number	Area name	Countries or areas*
1	LONDON	England, Morocco, GMT (Greenwich mean time)
2	PARIS	Austria, France, Germany, Italy, Netherlands, Spain, Sweden, Switzerland, Portugal, CST (Continental Standard Time), Tunisia
3	CAIRO	Egypt, Finland, Greece, Turkey
4	MOSCOW	Ethiopia, Iraq, Kenya, Mauritius, Saudi Arabia, Seychelles, Russia (Moscow)
5	DUBAI	United Arab Emirates
6	KARACHI	Maldives, Pakistan
7	DACCA	Bangladesh, India, Myanmar
8	BANGKOK	Cambodia, Indonesia (Jakarta), Thailand, Vietnam
9	HNGKNG	Australia (Perth), China, Hong Kong, Indonesia (Borneo, Bali), Malaysia, Philippines, Singapore, Taiwan
10	TOKYO	Japan, Korea
11	SYDNEY	Australia (Sydney)
12	SOLOMON	New Caledonia
13	WLLNGTN	Fiji, New Zealand
14	SAMOA	Western Samoa
15	HAWAII	Hawaii Is., Tahiti, HST (Hawaii Standard Time)
16	ANCHRGE	U.S.A. (Alaska), AST (Alaska Standard Time)
17	L.A.	U.S.A. (Los Angeles, San Francisco), PST (Pacific Standard Time)
18	DENVER	U.S.A. (Denver), MST (Mountain Standard Time)
19	CHICAGO	Mexico, U.S.A. (Chicago), CST (Central Standard Time)
20	NEWYORK	Canada (Montreal), Jamaica, Peru, U.S.A. (New York, Washington D.C.), EST (Eastern Standard Time)
21	CARACAS	Chile, Dominica, Venezuela
22	RIO	Argentina, Brazil, Uruguay
23	FN ISL.	Fernando de Noronha
24	AZORES	Azores Islands

* These are common names. The formal may be different.

Preparation

Preparation

Picture/Backlight Adjustments 5

Press ◀ or ▶ to adjust the picture or backlight to your preference.

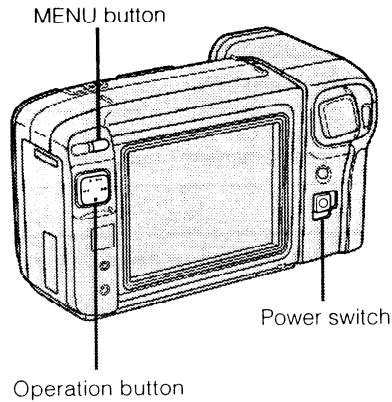

If the picture is difficult to see due to ambient lighting, etc., adjust the monitor picture.

- 1 Set the Power switch to CAMERA.

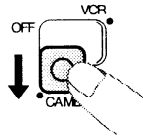

- 2 Press the MENU button until function screen 4/4 appears on the monitor.

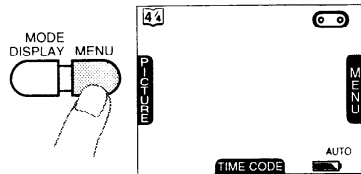

- 3 Press ◀ on the Operation button (⏮) to select "PICTURE".

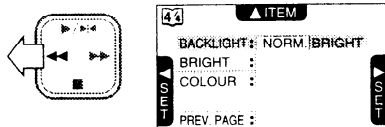

- 4 Press ■ or ▶/▶▶ on the ⏮ button to select the menu item you wish to adjust.

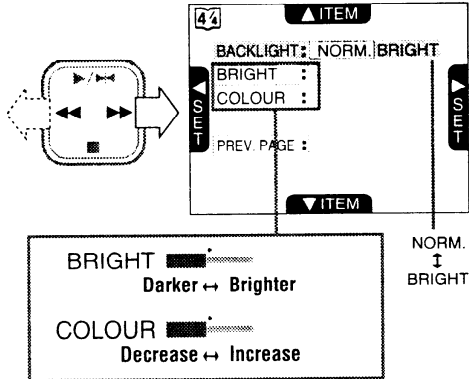
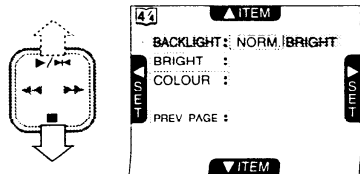

- 6 When you are finished, press the MENU button to turn off the adjustment display.

When the VIEWCAM is in VCR Mode

Press the MENU button until 2/3 appears on the monitor. Then perform steps 3 through 6 shown above.

Notes:

- In bright daylight, the monitor picture will be easier to see if you set the backlight ("BACKLIGHT") to "BRIGHT".
- The picture adjustments have been factory preset to neutral settings, and the backlight mode ("BACKLIGHT") has been factory preset to normal ("NORM.").
- When the colour is adjusted, the picture on the screen may differ from the picture actually recorded. Do not change the colour settings unless it is necessary.

Using the Hand Strap

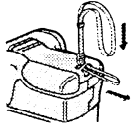
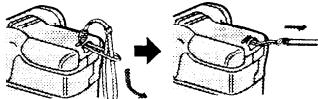
- 1 Thread the narrow end of the hand strap through the VIEWCAM's hand strap eyelet. Then pass the wide end of the strap through the narrow loop at the other end. 
- 2 Pull the wide end and tighten the strap. 

Fixing the Hand Strap on Your Wrist

Pass your right hand through the loop of the hand strap. Then move the slider toward your wrist until the strap fits your wrist snugly.

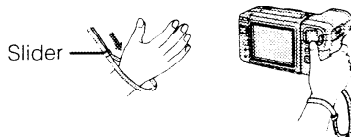

Caution:

- Be careful not to drop the VIEWCAM when attaching the hand strap, or during operation.

Using the Tripod Adaptor

When you use the VIEWCAM with a tripod, you must first attach the supplied tripod adaptor to the VIEWCAM.

Raise the adaptor's screw latch, and turn the latch clockwise to firmly fix the screw into the VIEWCAM's tripod adaptor socket.

- To connect your tripod to the tripod adaptor, firmly fix the mounting plate screw of your tripod into the adaptor's tripod socket. For details, see the user's manual for your tripod.

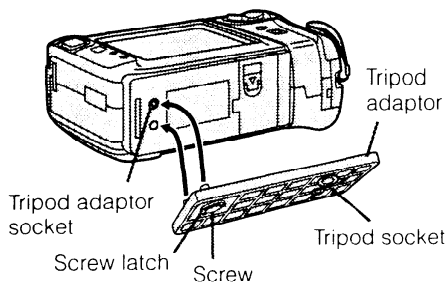

Caution:

- Do not connect your tripod to the VIEWCAM without using the tripod adaptor. The tripod may not balance properly and fall over, resulting in serious damage to the VIEWCAM.

Attaching the Shoulder Strap

- 1 Hold one end of the strap and thread it through the loop below the speaker on the lens section. **Note:**
 - If the hand strap is attached to the loop, remove it first.
- 2 Thread the end of the strap through the long slider and move the long slider in the direction of the arrow to secure.
- 3 Loosen the buckle, and then pass the strap through it.
- 4 Draw the strap in the direction of the arrow (1), and then secure the end of the strap with the short slider (2).
- 5-8 Use the same procedure to attach the other end of the strap to the loop above the speaker.

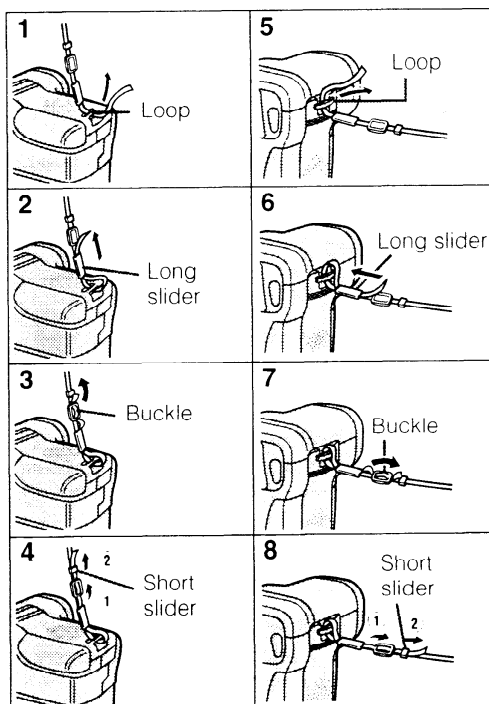

Handling the LCD Monitor

- Do not let anything press against the monitor screen, and do not expose it to shock, as it may break.
- Do not put the VIEWCAM on a table, or any other surface, with the monitor screen facing down.
- Use a soft cloth to clean the screen.

Basic Operations Camera Recording

- Refer to pages 19–21 on how to operate the monitor display.

Unlike conventional camcorders, this model frees you from having to peer into a small viewfinder. You can watch the subject on the large LCD monitor screen for easier, more enjoyable video-shooting.

Easy Camera Recording with Full Auto

Basic Operations
Camera Recording

Before you start recording, perform the operations described on pages 13 through 28 to prepare your VIEWCAM for recording.

- 1 Hold down the lock button and slide the Power switch to CAMERA.
 - The picture from the lens is now displayed on the LCD monitor.

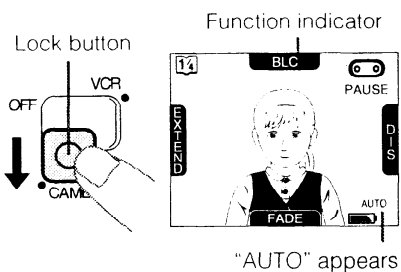

- 2 Press the REC START/STOP button to start recording.

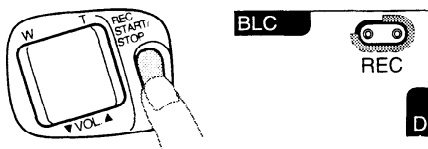

Note:

- When you set the Power switch to CAMERA, it may take some time before the screen appears. Wait until the screen appears, then start operation.

To Pause Recording

Press the REC START/STOP button again. Recording pauses, and the VIEWCAM enters Recording Standby mode.

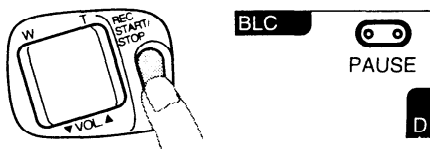

E 29

To Turn the Power Off

Slide the Power switch to OFF without pressing the Lock button.

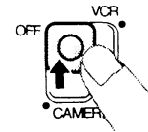

Notes:

- To leave Camera Recording mode, set the Power switch to OFF.
- During Camera Recording mode, the speaker is off, and the PHONES (earphones) jack cannot be used.
- If the VIEWCAM is kept in Recording Standby mode for more than approximately 5 minutes, the power will automatically turn off to save battery power and to protect the tape from being damaged. To continue recording after this, set the Power switch to OFF, and then back to CAMERA again.
- If you will not be recording again for a while, turn the power off. This will make the battery last longer.
- The operation indicators can be turned off or back on again with the MODE DISPLAY button.
- The date and time, once set, will be internally recorded even if they do not appear on the screen. You can also turn them on or off on the screen. See page 25 for details.

Maximum Time for Continuous Camera Recording and Playback

Battery pack	Max. camera recording time	Max. playback time
BT-L2	Approx. 50 min.	Approx. 50 min.

Notes:

- The use of the zoom and other functions will accelerate power consumption. The actual recording time per battery pack may be 30%–50% less than the maximum camera recording time shown above.
- The above playback time is based on operation of the VIEWCAM without use of the A/V pack and with the volume set at the middle setting.

Zooming

Zooming allows you to move visually closer to or farther from a subject without physically changing your position.

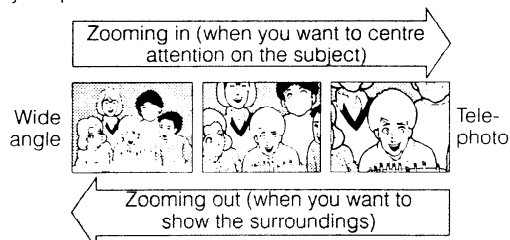

To Zoom In

Press the Power Zoom T (telephoto) button to get a close-up view (1).

To Zoom Out

Press the Power Zoom W (wide angle) button to get a wide field of view (2).

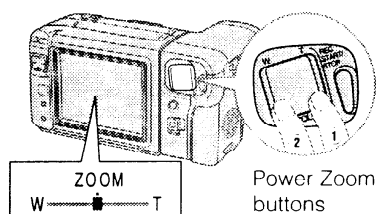

- The zoom speed changes depending on the degree of pressure placed on the Power Zoom buttons.
- The on-screen display will show you the current zoom setting.

Notes:

- The VIEWCAM is unable to focus when zooming in on subjects within 1.5 m. The VIEWCAM will automatically zoom out until it focuses on the subject.
- Frequent zooming produces unattractive pictures. It also increases battery power consumption.

Setting the Digital Zoom

You can select between two different zoom ranges: 1–12× optical zoom or 12–30× digital zoom. The 12–30× digital zoom allows you to record powerful close-up pictures with the same operation as normal zooming. The zoom range is factory preset to 1–12× optical zoom. In the 12–30× zoom range, the picture quality may suffer slightly.

- 1 Press the MENU button until function screen 44 appears on the monitor (Camera mode).

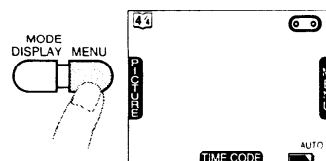

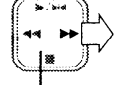
- 2 Press \blacktriangleright on the Operation button () to select "MENU".

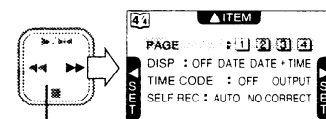

Operation button

- 3 Press \blacktriangleright on the  button to select MENU-PAGE 21 (1), then press \blacksquare to select "DGTL ZOOM" (2).

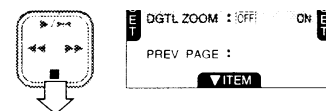
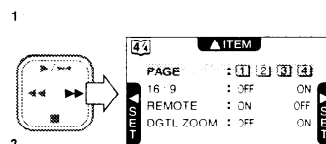

- 4 Press \blacktriangleright to select "ON".

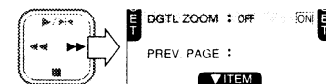

- 5 The digital zoom is now on. Press the MENU button to turn off the menu.

To return to normal zoom, set "DGTL ZOOM" to "OFF" in step 4 above.





Note:

- When the digital zoom is used, the picture quality may suffer. At maximum zoom, the horizontal resolution decreases by a maximum of 60% of the optical zoom.

Digital Quick Zoom (Extend Zoom)

Use the digital quick zoom function (extend zoom) to instantly zoom in on a subject. This is useful when you want to instantly capture a particular subject.

Setting the Digital Quick Zoom Ranges



Refer to page 20 to display function screen  and select MENU-PAGE , and then press  on the Operation button () to select "EXTEND ZOOM".

Press  or  on the  button to select "1.5", "2.0" or "2.5" x.





Using Digital Quick Zoom (Extend Zoom)

1 Press the MENU button until  appears on the monitor (Camera mode). 

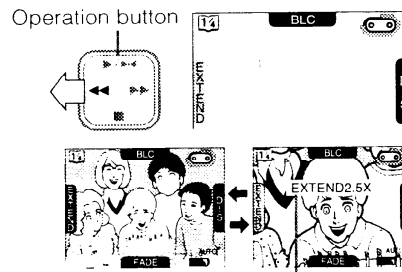
2 During recording, press  on the Operation button () to select "EXTEND" when you want to instantly zoom in on a subject.



"EXTEND 1.5x", "EXTEND 2.0x" or "EXTEND 2.5x" is displayed.









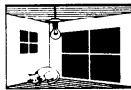

To return to the previous magnification, press  on the  button to select "EXTEND" again.

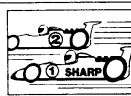
Notes:

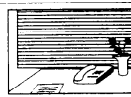
- When the digital quick zoom is used, the picture quality decreases by a maximum of 60% of the optical zoom.
- The digital quick zoom (extend zoom) function does not work in the digital zoom (12-30x) range. ("EXTEND" is faintly displayed.)
- When the extend zoom is on with the optical zoom at 12x, 1.5x becomes 18x, 2.0x becomes 24x, and 2.5x becomes 30x.

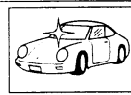
Auto Focus

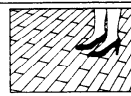
The auto focus feature is designed to focus on most types of subjects. In Auto Focus mode, the VIEWCAM automatically focuses on whatever is in the centre of the scene. Always keep the subject in the centre of the screen. The auto focus may not be able to focus on the subject in the situations shown in the chart. In such situations, set the VIEWCAM to Manual Focus mode and focus manually (see page 52).

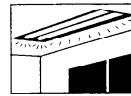
 Subject is too dark	 Lack of contrast, e.g. snow scene
 Fast-moving subject	 Background is too bright
 Subject has vertical or horizontal stripes.	 Subject is being shot through a dirty or wet window.
 Light reflects off the subject	 Two subjects at different distances overlap in the same scene.
 Subject has fine, repeated patterns.	 Subjects at different distances appear in the centre of the scene at the same time.
 High-speed shutter being used under fluorescent lighting.	

Notes:

- If no subject is in the centre of the monitor, the focus area will expand and the subject nearest the centre will be focused on.
- If no subject is displayed on the monitor, the VIEWCAM will automatically zoom out until some subject comes into the frame.
- If the image being recorded is not sharp, the auto focus may not function and the image will be blurred. If this occurs, press the Power Zoom W button to zoom out, or pan the VIEWCAM to shoot some other subject. The auto focus will resume operation.

Backlight Compensation (BLC)

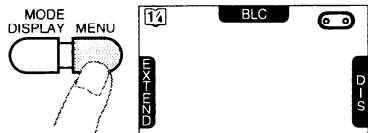

When the subject is backlit, the image will be darkened if it is recorded normally. Use the backlight compensation (BLC) feature to improve the picture.

- 1 Press the MENU button until  appears on the monitor (Camera mode).





Note:

- At locations where lighting is insufficient, "LIGHT" appears on the monitor. "GAIN-UP" instead of "BLC" appears indicating the BLC function cannot be used.

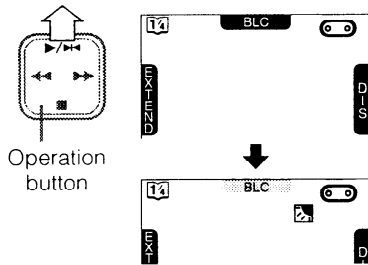
- 2 Press  on the Operation button () to select "BLC". The backlight compensation indicator  appears on the monitor, indicating that the BLC function is now working.



To turn off the BLC function, press  on the  button to select "BLC" again. The  indicator goes off.

Gain-up (Cat's Eye)

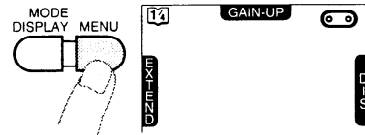

When you are recording in a dark or poorly illuminated location, "LIGHT" (warning of too little ambient illumination) is displayed on the monitor. Use the gain-up feature to record a brighter picture.

- 1 Press the MENU button until  appears on the monitor (Camera mode).





Note:

- At locations where lighting is adequate, the "LIGHT" indicator will not appear. "BLC" instead of "GAIN-UP" appears indicating the gain-up function cannot be used.

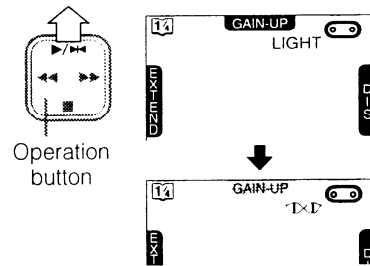
- 2 Press  on the Operation button () to select "GAIN-UP". The "LIGHT" display changes to the gain-up (cat's eye) display , indicating that the gain-up function is now working.



To turn off the gain-up function, press  on the  button to select "GAIN-UP" again. The  display changes to the "LIGHT" display.

Notes:

- If the VIEWCAM is moved to a bright location after it is engaged in Gain-up mode, the Gain-up mode will disengage automatically.
- There is more picture noise in Gain-up mode.

Digital Image Stabilization (DIS)

The DIS function lets you stabilize the image by electronically cancelling relatively small image shakes that are often annoying in close-up shots.

Basic Operations
Camera Recording

- 1 Press the MENU button until appears on the monitor (Camera mode).

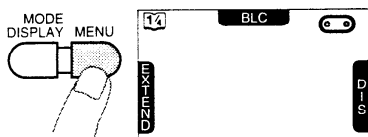

- 2 Press on the Operation button () to select "DIS". The "⚡" indicator appears on the monitor, and the VIEWCAM enters DIS mode.

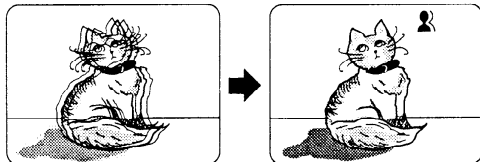
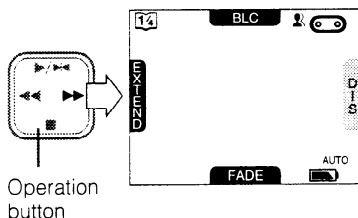

To return to normal recording mode, press on the button to select "DIS" again. The "⚡" indicator will disappear.

Notes:

- While this function is in progress, the image on the monitor is slightly magnified, and the shutter speed is automatically switched from the standard speed ($\frac{1}{50}$ sec.) to $\frac{1}{120}$ sec.
- Image resolution slightly decreases in DIS mode.
- Under the light of fluorescent lamps, the picture may brighten and dim.
- The DIS feature does not work during Still Recording mode.
- Battery consumption is larger in DIS mode. We recommend that you not use the DIS feature when using the VIEWCAM on a tripod.

Caution:

- The DIS function cannot compensate for excessive image shake, or for the subjects or situations described below.
 - Subject with low contrast*
 - Subject with a plain background*
 - Dark or dimly lit subject*
 - Subject with vertical or horizontal stripes
 - Many moving subjects in a single frame (*The "⚡" indicator blinks during these conditions.)

Macro Shots

This VIEWCAM lets you shoot close-up images of small objects such as flowers and insects, or make title frames for your videos. When you want to record a magnified image of a subject which is within approximately 1.5 m of the VIEWCAM, do not zoom in on the subject. Instead, zoom out all the way by holding down the Power Zoom W button, and then move the VIEWCAM closer to the subject until you obtain the desired angle of view. The VIEWCAM will automatically focus on the subject when the lens is set for the widest angle.

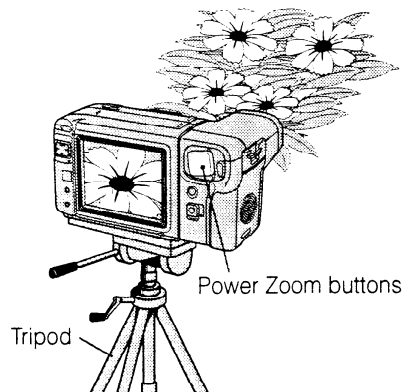

Notes:

- When you are recording a macro shot, be sure that the subject receives sufficient illumination.
- It is recommended that you use a tripod for recording macro shots, to prevent image shake.
- Before you mount the VIEWCAM on a tripod, be sure to connect the supplied tripod adaptor to the VIEWCAM (see page 28).

Fade In and Fade Out

With the fade function, it is possible to fade in or fade out scenes smoothly. It is effective especially for indicating a dramatic change in scenery.

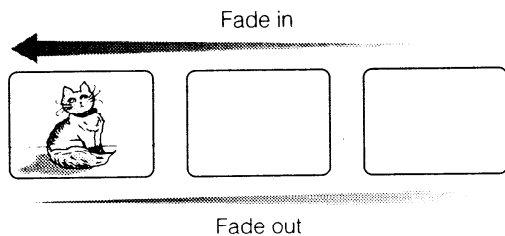

Fade In

- 1 Press the MENU button until 14 appears on the monitor (Camera mode).

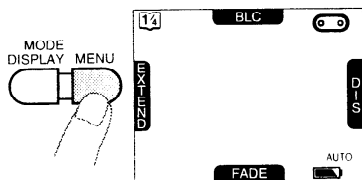

- 2 Press \blacksquare on the Operation button (⏏) to select "FADE".
 - "FADE" appears on the monitor.

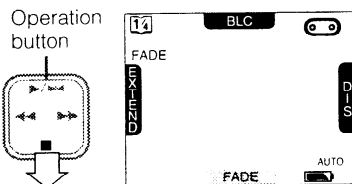

- 3 Press the REC START/STOP button. "FADE" changes to "FADE IN", and after the screen turns white, recording begins and the picture and sound fade into the monitor screen.

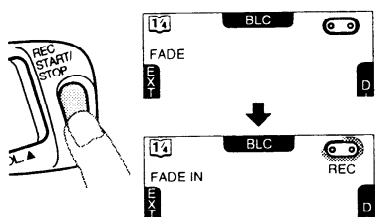

Fade Out

- 1 Press the MENU button until 14 appears on the monitor (Camera mode).

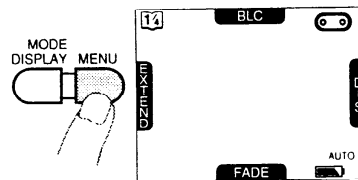

- 2 Press the REC START/STOP button to start recording.

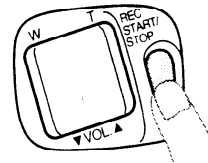

- 3 Press \blacksquare on the Operation button (⏏) to select "FADE".
 - "FADE" appears on the monitor.

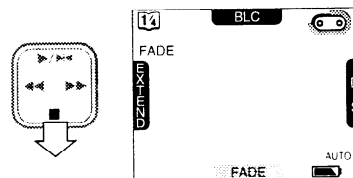

- 4 Press the REC START/STOP button at the point where you wish to stop recording. "FADE" changes to "FADE OUT", and the picture and sound fade out as the screen gradually turns white. The VIEWCAM then returns to Recording Standby mode.

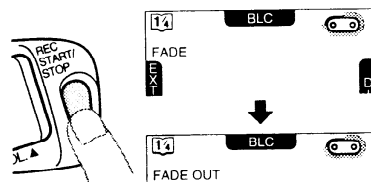

Basic Operations

Camera Recording

Recording with the Wide Screen (16:9)

This feature lets you record scenes with the wide-screen feel of a movie shown in a theatre. The top and the bottom of the picture are masked with black bands to produce an effective screen aspect ratio of 16:9.

- To return to the normal picture, press ◀ to select "OFF" in step 4 above.

Notes:

- When using the fade function (see page 34) in the Wide Screen mode, only the unmasked portion of the screen will fade in or out.
- You can only use the Wide Screen mode when the VIEWCAM is in Camera mode.

Basic Operations Camera Recording

Setting the Wide Screen Mode

- Press the MENU button until 44 appears on the monitor (Camera mode).

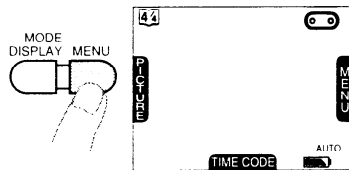

- Press ▶▶ on the Operation button (◻) to select "MENU".

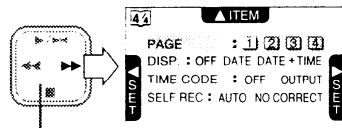

Operation button

- Press ▶▶ on the ◻ button to select MENU-PAGE 2 (1) and then press ■ to select "16:9" (2).

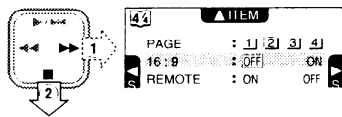

- Press ▶▶ to select "ON". Then, press the MENU button to turn off the menu.

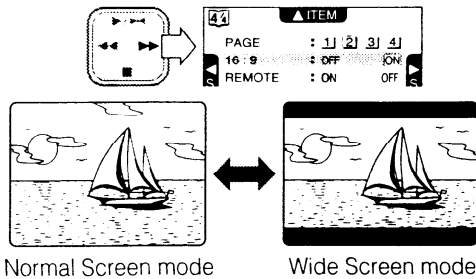

Quick Return

When you have been playing back what you have recorded, and wish to quickly return to recording again from the end of the last recorded scene, use the quick return function.

- 1 Set the Power switch to CAMERA.

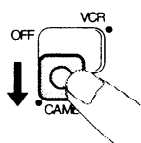

- 2 Press the MENU button until 24 appears on the monitor.

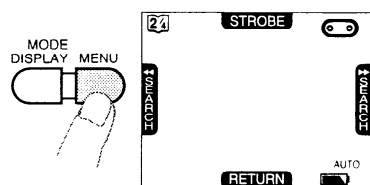

- 3 Press ■ on the Operation button (⏮) to select "RETURN". The tape will begin winding or rewinding to the end of the last recorded scene.

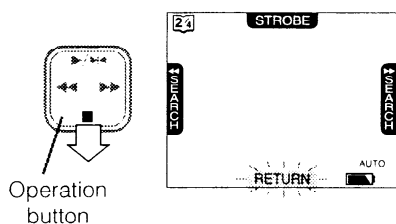

- To cancel, press ■ on the ⏮ button to select "RETURN" again.

- 4 When the tape reaches the end of the last recorded scene, the VIEWCAM enters Recording Standby mode.

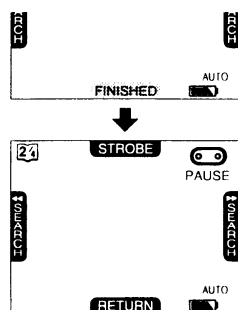

Note:

- If the cassette has been removed since the last recording, or if no recording has been made since the cassette was loaded, "RETURN" indicator will be faintly displayed and the quick return function will not operate.

Edit Search

The edit search feature lets you search, without switching from Camera Recording mode to VCR mode, for the point on the tape where you wish to start recording next.

- 1 In Recording Standby mode, press the MENU button until 24 appears on the monitor.

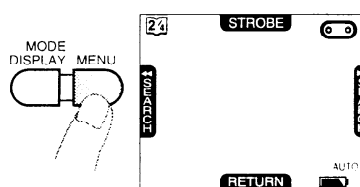

- 2 Hold down ◀ for reverse edit search or ▶ for forward edit search on the ⏮ button.

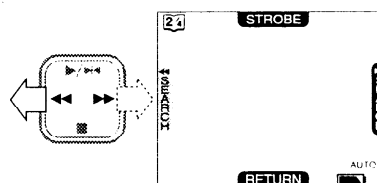

- 3 When you find the point where you want to begin recording, release the button.

Notes:

- Some picture noise appears during reverse edit search.
- Forward edit search is performed at the same speed as normal playback, and reverse edit search is performed at five times the normal playback speed.
- The sound is off during edit search.

Tips on Recording Positions

The rotating LCD monitor screen lets you enjoy easy video recording in relaxed postures.

- You can record using more natural body postures since you can see the subject on-screen, without having to hold the VIEWCAM against your eye
- The LCD monitor also makes high-angle and low-angle shots easy.
- In hand-held recording, the VIEWCAM has to be steadied to prevent image shake.
- Use a tripod for very stable recording.

Basic Recording Positions

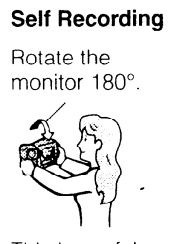
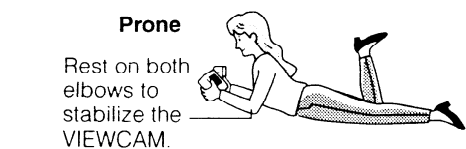
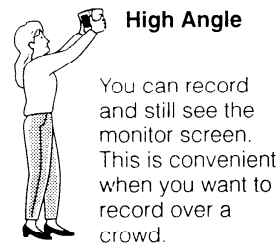
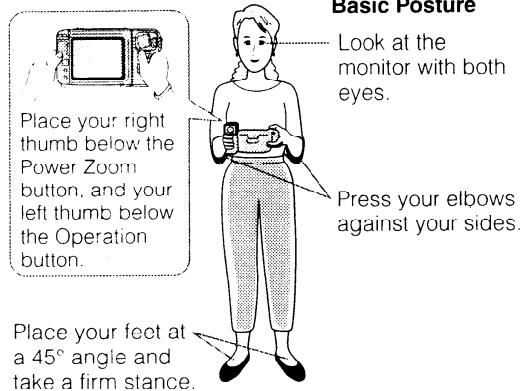

This is useful when you want to record your own portrait by yourself, or record yourself and your friends together.

Notes:

- Take care not to touch the monitor screen with your fingers, as perspiration and dirt will smudge it.
- Unless you intend to create a special effect, keep the VIEWCAM level with the horizontal plane.
- Take care not to touch the microphone with your fingers when the VIEWCAM is recording. It will cause noise on the audio track.

Hints for Better Shooting

- Position the subject in the centre of the screen. When you are using auto focus, whatever is in the centre of the screen is kept in focus.



Position the subject in the centre.



Focus manually when you need to position the subject off centre (see page 52).

- Avoid backlit subjects. For the best picture, have the light source behind you. When the background is brighter than the subject, the subject often becomes too dark. If you need to record with this lighting, correct the gain or iris to improve the picture (see pages 32 and 55).



- Before zooming, think about how to best frame the shot. Stop zooming when the shot is well framed.
- When image shake is noticeable during zoomed-in telephoto shooting, use a tripod, or press the Power Zoom W (wide angle) button to zoom out. (See page 28 for the use of the tripod adaptor.)
- Horizontal panning (lateral movement) and tilting (vertical movement) should be done slowly to emphasize the wide expanse of a scene or the height of a building, and to make them easy to watch on playback.
- Use wide-angle settings for fast-moving subjects.





Note:

- It may take longer to focus when zooming and panning are used frequently.



Setting the VIEWCAM to Full Auto Mode

This VIEWCAM is equipped with auto focus, auto white balance, auto exposure, and auto shutter speed functions. Set the VIEWCAM to Full Auto mode and you can record high-quality pictures easily.

When "AUTO" is not displayed on the monitor, the VIEWCAM is not in Full Auto mode. Perform the procedure below to set the VIEWCAM to Full Auto mode.

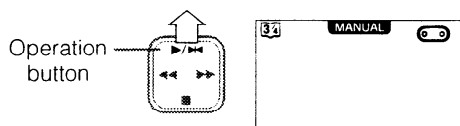
- 1 While the VIEWCAM is in Camera mode, press the MENU button until **34** appears.
Note:
 - If the VIEWCAM is in Manual Focus mode ("FOCUS" selected on **34** screen), press  on the  button to return to Auto Focus mode (see page 52).
- 2 Press  on the Operation button () to select "MANUAL".



- 3 Select "CAMERA MODE" and then press  on the  button to select "AUTO".



- 4 Press the MENU button until **14** appears. "AUTO" is displayed on the monitor. During normal recording, use the **14** screen for the Full Auto mode.

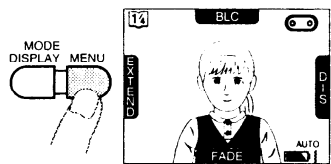

"AUTO" indicator

Basic Operations

Camera Recording

Remaining Recording Time Display

When the VIEWCAM is recording, an on-screen indicator will begin to show how much time you have left, as shown below. You might want to get a new tape ready at this time. To turn off the remaining recording time display, press the MODE DISPLAY button.

Basic Operations
Camera Recording

MODE DISPLAY button

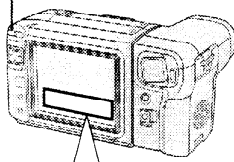

Approx. remaining recording time	Monitor display
Less than half of the tape remaining	
10 min.–8 min.	
8 min.–6 min.	
6 min.–4 min.	
4 min.–2 min.	
2 min.–1 min.	
1 min.–0 min.	<p>THE TAPE ENDS SOON.</p> <p>↓ (after 3 sec.)</p>
0 min. (The tape has reached its end.)	<p>CHANGE THE CASSETTE.</p> <p>↓ (after 3 sec.)</p> <p>TAPE END</p>

Notes:

- The time-remaining indicators only show approximate time left. Also, they vary slightly depending on the length of tape used. (This function's design is based on the DVM60 tape standard.)
- If you press the MODE DISPLAY button to turn off the remaining recording time display, this display will reappear after a short interval to indicate the new time remaining.
- **The time-remaining indicators above appear after 5 seconds from the time you press the REC START/STOP button to start recording.**

Remaining Battery Power Display

When you turn on the VIEWCAM, the remaining battery power display automatically appears on the monitor. By pressing the MODE DISPLAY button, you can turn the display on and off. The remaining power is displayed in five levels, as shown. If the battery power is very low, a warning message will appear. Replace the battery pack.

MODE DISPLAY button

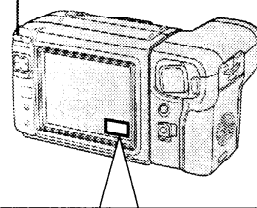

Monitor display	
	(Green)
	(Green)
	(Green)
	(Yellow)
	(Red)
5-level display	
BATTERY IS TOO LOW.	
↓	

Notes:

- Use the remaining battery power display only as an indication.
- Battery consumption may vary depending on the condition of use.
- The battery power display may change to either a higher or lower level if you set the Power switch to OFF and then back to CAMERA or VCR again.
- Use of the zoom functions when the warning message "BATTERY IS TOO LOW." is displayed may cause the VIEWCAM to suddenly lose power. Replace the battery pack.
- Remaining battery power display will not be displayed when the VIEWCAM is powered from an AC outlet or a car battery.

Using the Infrared Remote Control

Use the remote control to operate the VIEWCAM from a distance, such as when you want to record yourself in a scene, or when the VIEWCAM is connected to a TV for use as a VCR.

- 1 Set the Power switch to CAMERA or VCR.

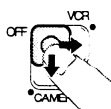

- 2 Press the MENU button until **44** (Camera mode) or **33** (VCR mode) appears on the monitor.

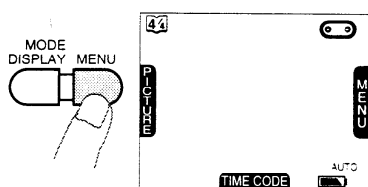

- 3 Press **▶▶** on the Operation button () to select "MENU".

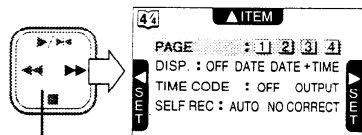

Operation button

- 4 Press **▶▶** on the  button to select MENU-PAGE **2** (**1**) and then press **■** to select "REMOTE" (**2**). Make sure that "REMOTE" is set to "ON".

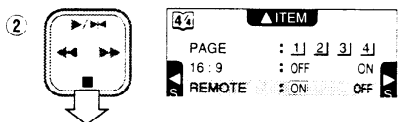
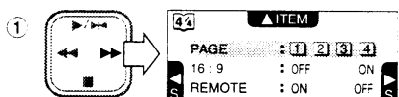

If "REMOTE" is set to "OFF", press **◀◀** to select "ON".

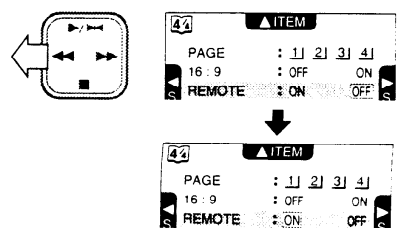

- 5 Aim the remote control at the photoreceptor of the VIEWCAM, and press the control buttons for operation.

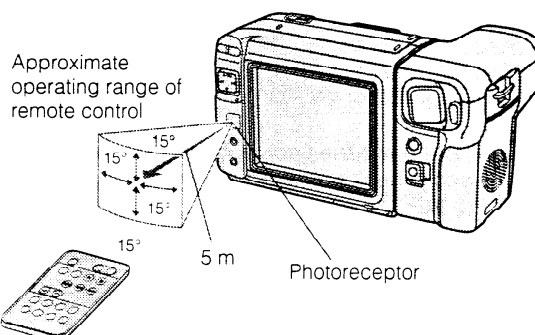

Notes:

- Be careful not to allow direct sunlight or bright light from interior illumination to fall onto the VIEWCAM's photoreceptor, as this may prevent the remote control from operating properly.
- Be sure that there are no obstacles between the remote control and the VIEWCAM's photoreceptor.
- When the "REMOTE" setting is changed in either Camera or VCR mode, the setting for the other mode is automatically set to the same.
- The lithium battery normally lasts about one year. It can be shorter under some operating conditions. When the lithium battery is dead and the remote control does not operate, replace the battery with a new one following the instructions on page 13.
- The **▶**, **▶▶**, **■**, **◀◀**, or **▶▶** buttons on the remote control cannot be used to move the cursor, or select or set any of the various functions on the monitor.

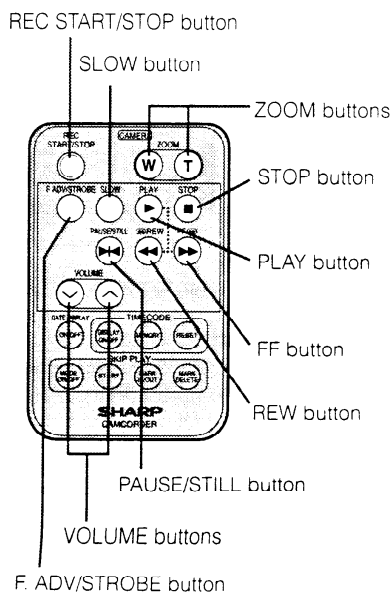

Basic Operations Playback

- Refer to pages 19–21 on how to operate the monitor display.

Playback

The LCD monitor makes it possible to play back and see what you have just recorded. Nothing needs to be connected, allowing instant on-screen playback. You can hear the sound through the built-in speaker or via your own stereo earphones.

- 1 Hold down the Lock button and slide the Power switch to VCR.
 - It may take some time before the screen appears. Wait until the screen appears, then start operation.

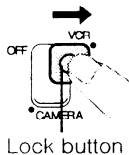

- Stereo earphones with a 3.5 mm diameter plug can be plugged directly into the PHONES jack. When you use this jack, the speaker automatically turns off.

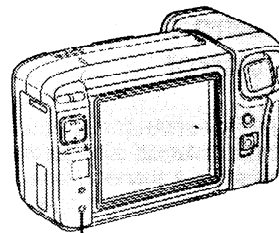

PHONES jack

Caution:

- To use the remote control, make sure that the remote control menu item ("REMOTE") is set to "ON". The remote control cannot be used to operate the VIEWCAM when this is set to "OFF". See page 40.

- 2 Press the MENU button until appears on the monitor.

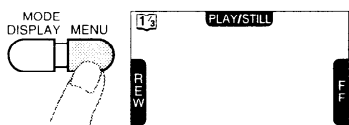

- 3 If the tape is not at the desired point, press or on the Operation button () to select "FF" (1) or "REW" (2).

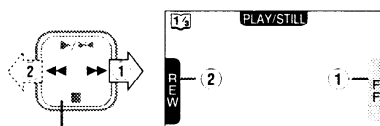

Operation button

- 4 Press to select "PLAY".

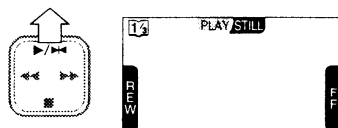

Volume Control

While the VIEWCAM is in the VCR mode, press the VOL. or button to increase or decrease the volume to your preference.

The volume control indicator will appear on the monitor. After adjusting the volume, if the Volume control buttons are not pressed, the indicator will disappear by itself shortly.

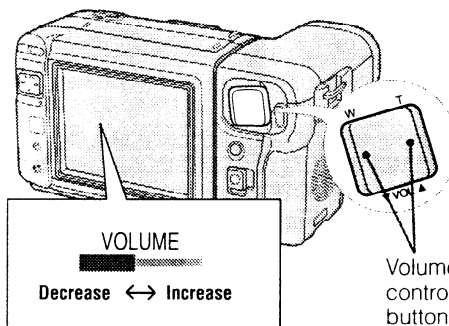

Volume control buttons

Note:

- The volume can also be adjusted with the remote control.

Fast Forward and Rewind

During a stop mode, press or on the button to select "FF" (Fast Forward) or "REW" (Rewind) on the screen (VCR mode).

To Stop Playback

Press on the button to select "STOP".

Auto Tape Rewind

The tape is automatically rewound when playback reaches the end of the tape.

Notes:

- If you wish to turn off the operation indicators on the monitor (e.g. because they interfere with your view of the picture), press the MODE DISPLAY button. The buttons will still function as indicated even after their indicators are turned off.

Displaying the Date and Time of Recording

The date and time, once set, are stored in memory. You can display them on the monitor during playback even if they were off during recording.

- 1 Display the menu screen (VCR mode) using the MENU button and the Operation button (◀▶).

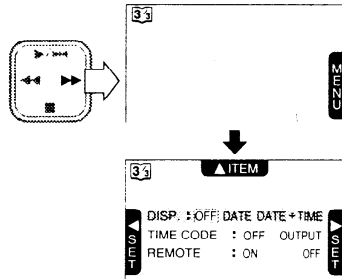

- 2 Select "DISP." and set it to "DATE" or "DATE+TIME" using the ◀▶ button.

Notes:

- You can also display the date and time by pressing the DATE DISPLAY ON/OFF button on the remote control. (When the tape is not running, the current date or time will be displayed.)
- If you wish to display the date and time during playback, make sure, before recording, that the date and time have been set correctly. If they are not set, "----:--" will be displayed. This will also be displayed on blank or damaged portions of the tape.

Video Search

This function makes it easy for you to search for a scene near the current tape position.

- 1 During playback, press ▶▶ on the Operation button (◀▶) to select "FF" (1) (or ◀◀ to select "REW" [2]) on the 1/3 screen (VCR mode). The fast forward (or reverse) playback picture is displayed on-screen.

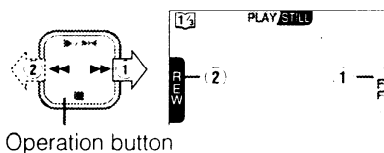

Operation button

- 2 When you find the desired scene, press ▶/◀ on the ◀▶ button to select "PLAY" to return to normal playback.

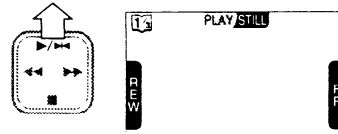

Notes:

- The sound is off during search.
- Some picture noise appears during search. This is not a malfunction.

Still

This function makes it possible to freeze the picture. During playback, press ▶/◀ on the ◀▶ button to select "STILL" on the 1/3 screen (VCR mode). To return to normal playback, press ▶/◀ to select "STILL" once again.

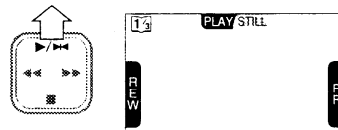

Slow

This function makes it possible to play back in slow motion. During playback, press the SLOW button on the remote control. To return to normal playback, press PLAY button on the remote control to select "PLAY".

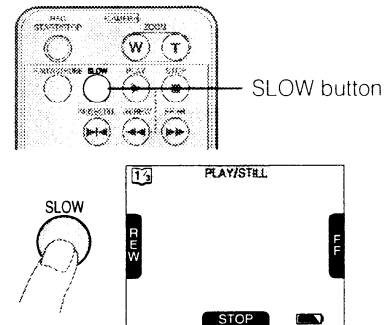

Notes:

- The sound is off during Still and Slow modes.
- To protect the tape, the VIEWCAM automatically returns to ordinary playback if it is left in Still mode for more than 5 minutes or in Slow mode for more than about 40 seconds.
- Still image playback can also be operated with the remote control. (See page 40.)
- If still or slow functions are used when connected to a TV, noise will appear and distort the image.
- Slow function cannot be operated from the VIEW-CAM.

Basic Operations

Playback

Frame Advance

During **still picture playback**, press the F.ADV/STROBE button on the remote control. Each time you press the button, the picture advances one frame.

To return to normal playback, press the PLAY button (▶).

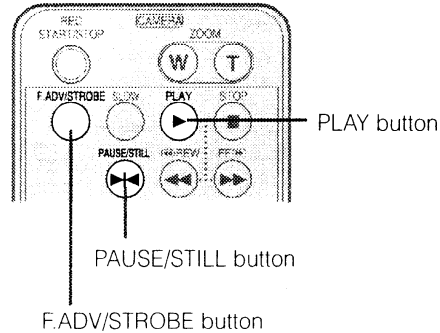

Basic Operations
Playback

Strobe Playback

During **normal playback**, press the F.ADV/STROBE button on the remote control. The VIEWCAM plays back one frame at a time at approximately 1/4 sec. intervals.

To return to normal playback, press the PLAY button (▶).

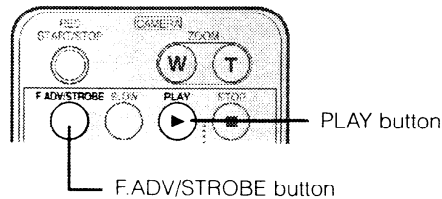

Note:

- Frame advance and strobe playback functions cannot be controlled from the VIEWCAM.

Turning Off the LCD Monitor Backlight

This VIEWCAM's LCD monitor uses a fluorescent lamp for backlighting (see page 62). In order to reduce battery consumption, you can turn off the lamp when backlighting is not necessary (e.g. when you are watching a playback on a connected TV's screen).

While the VIEWCAM is in Camera or VCR mode, hold down the MODE DISPLAY button for more than 5 seconds. The backlight will turn off and the LAMP OFF indicator will light up. To turn it on again, press the MODE DISPLAY button, or set the Power switch to OFF and then back to CAMERA or VCR.

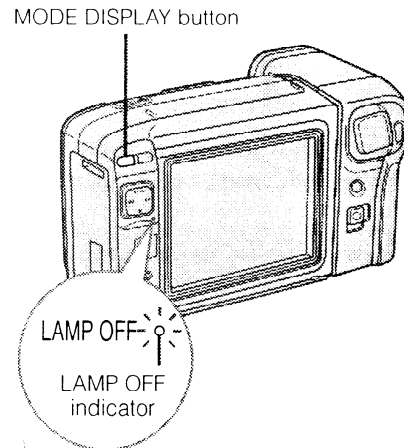

Notes:

- The LAMP OFF indicator will blink when the monitor is off to indicate that there is a warning message. Press the MODE DISPLAY button and check the message on the monitor.
- Turning the LCD monitor on and off repeatedly may deplete battery power.

Programme Search

The programme search feature automatically finds the beginning of a number of previously recorded scenes. Up to 10 different scenes can be found on one tape.

- 1 Set the Power switch to VCR.

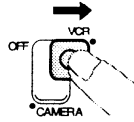

- 2 Press the MENU button until [2/3] screen appears on the monitor.

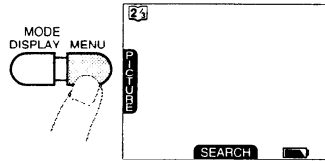

- 3 Press [] on the Operation button ([]) to select "SEARCH". The VIEWCAM enters the Programme Search mode. Both the "REW" and "FF" indicators, or one of them will start flashing. To cancel, press [] to select "SEARCH" again.

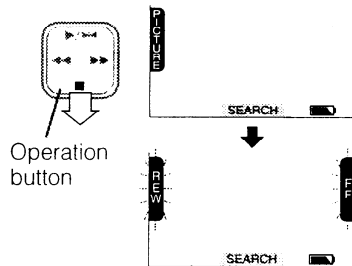

- 4 Press [] on the [] button to select "REW" (or [] to select "FF"). "SEARCH" will start flashing. The tape rewinds (or fast forwards) to the beginning of a scene immediately before (or after) the current tape position; playback then starts automatically. The "REW" and "FF" indicators automatically disappear after about 10 seconds.

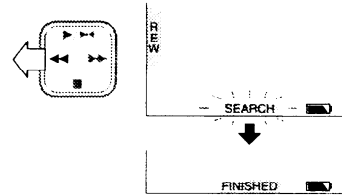

- 5 To continue searching, press [] to select "REW" (or [] to select "FF") while the "SEARCH" indicator is displayed.

Notes:

- Use this feature when the tape is stopped or being played back.
- This function finds the beginning of the scene immediately before or after the current tape position, stopping at every scene. It is not possible to skip a scene.
- This function cannot spot recordings that are shorter than 10 seconds in length.
- In steps 3 and 5, if the tape is at a point ahead of the most recent recording, only the "REW" indicator will flash, and the "FF" indicator will not appear.
- In steps 3 and 5, if the tape is at a point before the oldest recording, only the "FF" indicator will flash, and the "REW" indicator will not appear.
- This feature does not function if no recording has been made since the cassette was loaded, or if the cassette has been removed after the recordings were made. "SEARCH" is faintly displayed in this case.

Example: To find the beginning of five different scenes.

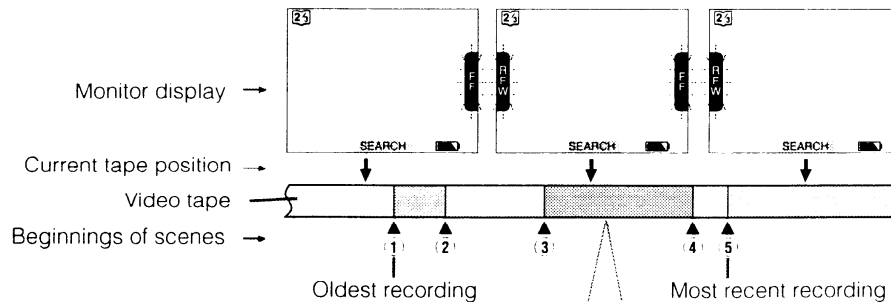

When you are at this position,
 Press [] on the [] button to select "REW" to rewind the tape to 3 and begin playback.
 Press [] on the [] button to select "FF" to forward the tape to 4 and begin playback.

Basic Operations

Playback

Using the Time Code

The time code allows you to record images together with the hour, minute and second of recording, and the frame number (1 frame = approx. 1/25 sec.). This can be displayed on the screen when needed, and used as an accurate counter.

- 1 Press the MENU button until **3/4** appears (VCR mode).

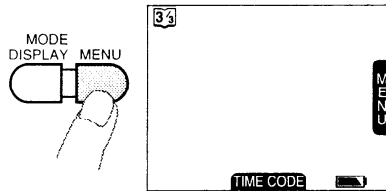

- 2 Press **■** on the Operation button (**⏮**) to select "TIME CODE". The time code display appears.

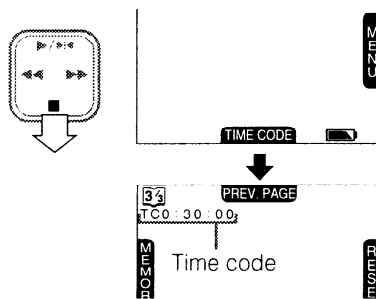

When images are played back in Still or Frame Advance mode, the time code is displayed for each frame. (During normal playback, only the hour, minute and second are displayed.)

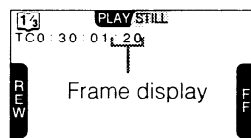

To turn off the time code display, press **■** on the **⏮** button again.

Displaying the Time Code with the Remote Control

Press the Time Code DISPLAY ON/OFF button on the remote control to display and turn off the time code.

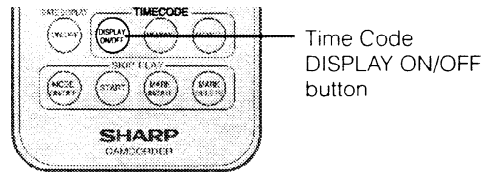

Displaying the Time Code on Your TV During Playback

- 1 Display the menu screen (VCR mode) on the monitor using the MENU button and the **⏮** button.

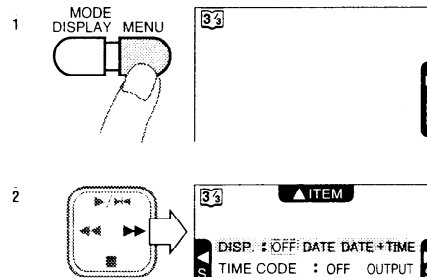

- 2 Select "TIME CODE" and set it to "OUTPUT" using the **⏮** button. (See pages 20 and 21 for menu setting.)

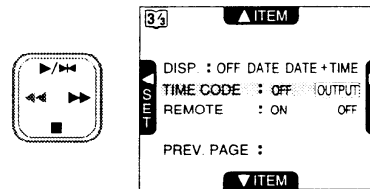

Notes:

- When the tape reaches an unrecorded section, the time code returns to zero (TC 0:00:00). Once recorded, the time code cannot be changed.
- The time code will remain displayed even if you press the MODE DISPLAY button to turn off the on-screen display.

Using the Tape Counter

Use the tape counter feature when you want to know the playback or recording time.

- 1 Press the MENU button until **3/3** (VCR mode) or **4/4** (Camera mode) appears on the monitor.

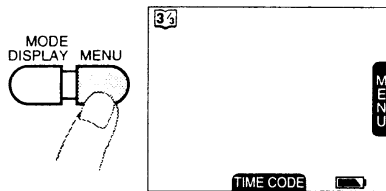

- 2 Press **■** on the Operation button (**⏮**) to select "TIME CODE". The time code display appears.

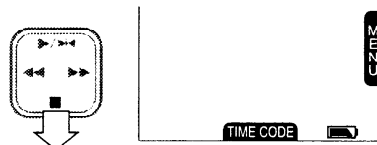

- 3 Press **▶▶** on the **⏮** button to select "RESET". The time code display changes to the tape counter.

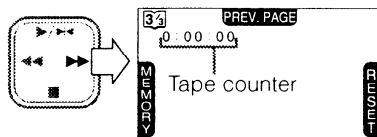

- 4 Begin recording or playback. You can check the recording or playback time on the monitor.

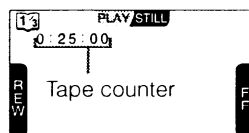

Counter Memory

Use the counter memory when you want to return to the beginning of a particular scene. The position where the counter memory is reset (0:00:00) is stored in memory to make it easier to return the tape to that point.

- 1 During playback or recording, display the time code on the monitor.

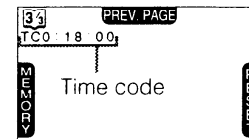

- 2 Press **◀◀** on the **⏮** button to select "MEMORY". The time code display changes to the counter memory display.

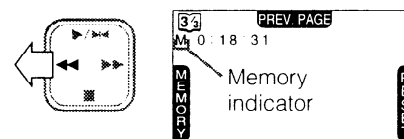

- 3 Press **▶▶** to select "RESET" at the beginning of a scene you want to return to later. The counter is reset to "M 0:00:00".

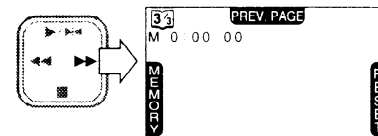

- 4 Stop the tape after playback. If you have been recording, stop the tape and set the Power switch to VCR.
- 5 Rewind the tape. The tape will automatically stop when the counter reaches 0:00:00.
- 6 Start playback to view the desired scene.

To cancel the Counter Memory mode

Repeat step 1 and press **◀◀** on the **⏮** button to select "MEMORY". The counter memory display will change to the normal time code display.

Notes:

- The Fast Forward function can be used in the same way.
- This function does not work during video searches.
- In step 5 above, the tape may stop slightly ahead or behind the point where you reset the counter to "M 0:00:00".

Basic Operations

Playback

Skip Playback

This feature automatically skips unwanted sections during playback. Use the SKIP PLAY operation buttons on the remote control to perform skip playback.

Basic Operations
Playback

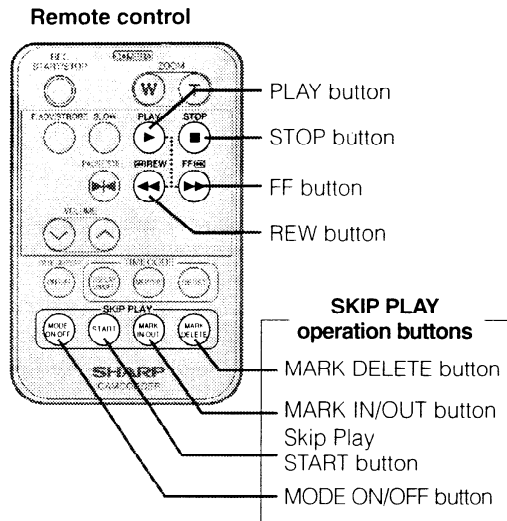

1 Set the Power switch to VCR.

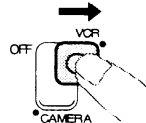

2 Press the Skip Play MODE ON/OFF button on the remote control. The VIEWCAM enters the Skip Play mode, and "SKIP PLAY" is displayed on the screen.

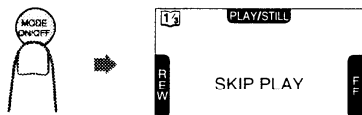

3 During playback, press the MARK IN/OUT button at the beginning of the section you wish to skip. The "SKIP PLAY" display changes to "MARK IN", which then changes to the flashing "MARK OUT" display after about five seconds.

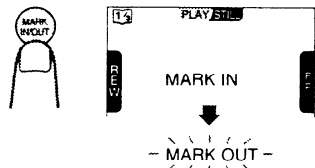

4 Press the MARK IN/OUT button at the end of the section you wish to skip. The "MARK OUT" display changes to "SKIP PLAY" after about five seconds.



Note:

- Repeat steps 3 and 4 to skip additional scenes.

5 Rewind the tape to the beginning of the playback section.

6 Press the Skip Play START button on the remote control. Skip playback starts. During the skipped section, "SEARCH MARK" flashes on the screen.

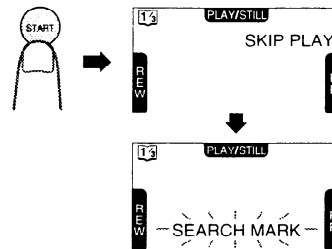

To stop skip playback



Press ■ on the Operation button () or press the STOP button on the remote control.

To disengage the Skip Play mode

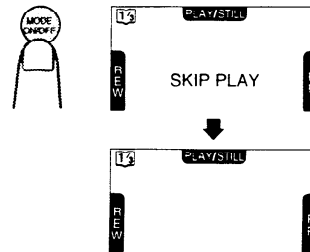
Press the Skip Play MODE ON/OFF button on the remote control. The "SKIP PLAY" display disappears.

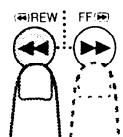

Deleting Skip Marks

- 1 In Skip Play mode, rewind or fast forward the tape to the beginning of the section with a skip mark.
 
- 2 Press the PLAY button to start playback.
 
- 3 When "MARK IN" or "MARK OUT" is displayed, hold down the Skip Play MARK DELETE button for two seconds.
 - The red "DELETE MARK" display will appear on the monitor, and the skip mark will be deleted. The red "DELETE MARK" display will then disappear, and the white "SKIP PLAY" display will appear on the monitor.

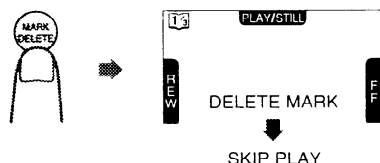

Note:

- This VIEWCAM uses two standardized DV (digital VCR) signals, Skip ID and Index ID, for skip playback. When deleting skip marks, Skip ID and Index ID signals pre-recorded on the tape may also be deleted.

To change a skipped section

Delete the skip mark to be changed, then add new skip marks, following steps 3 and 4 on page 47.

Notes:

- The SKIP PLAY operation buttons work only after the MODE ON/OFF button is pressed to engage the Skip Play mode.
- Leave about ten seconds between skip marks. If the interval between skip marks is less than ten seconds, the skip playback function may not operate correctly during playback.
- The skip playback function will not work with tapes recorded with camcorders other than this VIEWCAM.
- Skip marks cannot be added to a tape if the erasure protect tab is in the "SAVE" position.
- Fast forward and other functions cannot be used while the MARK IN/OUT signals are being recorded (approx. 5 sec. after the MARK IN/OUT button is pressed).
- Audio or video noise may occur when adding or deleting skip marks. This does not indicate a malfunction.

Example of Skip Playback

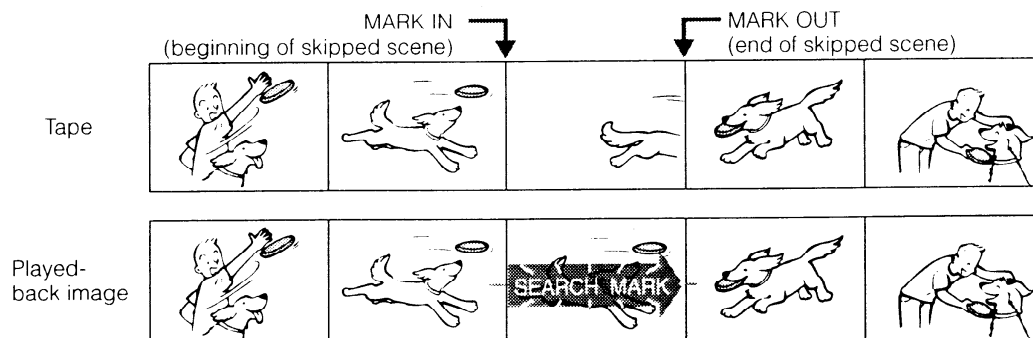

During search, a still image of the last scene is displayed.

Useful Features for Camera Recording

Self Recording

The LCD monitor can be rotated 180° vertically so that the monitor screen faces the subject. This lets you record yourself while watching yourself on the screen.

Enjoy recording your own portrait by yourself, or recording yourself and your friends together at a party.

Example of Recording in Self Recording Mode



Recording yourself and your friends together at a party, using the remote control, while monitoring yourselves on the VIEWCAM's screen.

Cautions:

- Do not rotate the monitor to the self recording position while the VIEWCAM is recording or playing back.
- For recording in Self Recording mode, be sure to rotate the monitor, NOT the lens. If you hold the VIEWCAM upside down with its lens at the bottom, the subject will be recorded upside down.

Normal Self Recording

- 1 Rotate the VIEWCAM's monitor section 180° vertically. The VIEWCAM will show a mirror image of the subject. Playback image will not be reversed even though the monitor shows the mirror image during self recording.

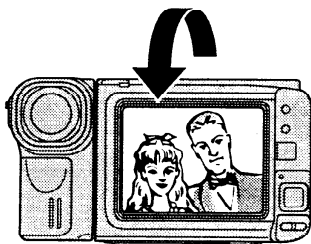

Note:

- If the image on the monitor is upside-down, return the monitor to the normal position and display MENU-PAGE 11 (Camera mode). Press ■ on the Operation button (⏏) to select "SELF REC" (1) and then press ◀ to select "AUTO" (2).

Operation button

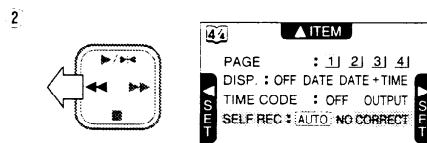
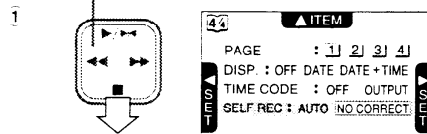

- 2 Press ◀ or ▶ to select "WIDE" or "TELE".

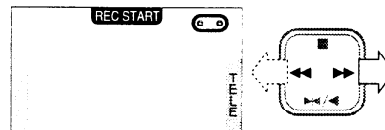

- 3 Press ■ to select "REC START".

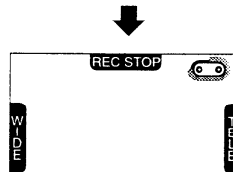
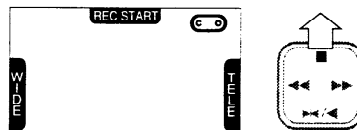

To pause recording, press ■ on the ⏏ button.

Self Recording Message OSD

In Self Recording mode, by following some simple instructions that appear on the monitor screen, you can easily record a short video message for somebody. This feature is especially convenient for editing video letters.

- Perform step 1 of "Normal Self Recording" on page 49, then perform the procedure below.

- 1 Press **▶/◀** on the Operation button () to select "MESSAGE". The instruction "PRESS REC START FOR LEAVING YOUR MESSAGE." appears on the monitor, and the "REC START" indicator starts flashing.

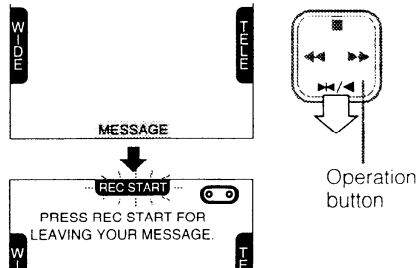

- 2 Press **■** on the  button to select "REC START". Say your message while facing the lens of the VIEWCAM.
 - The recording time is preset for 20 seconds.
 - The remaining number of seconds is displayed in the upper right hand corner of the monitor screen.

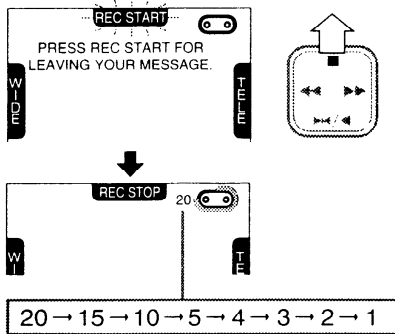

(remaining number of seconds)

- 3 When the remaining recording time reaches 5 seconds, "EXTEND" will flash.
 - When you want to extend the recording time, press **▶/◀** on the  button to select "EXTEND" within 5 seconds. After pressing the button, you may record continuously for 10 more seconds.



- 4 At the end of recording, the screen fades out, and recording stops automatically. The VIEWCAM returns to Recording Standby mode, and "PRESS REC START FOR LEAVING YOUR MESSAGE." appears again on the monitor screen.

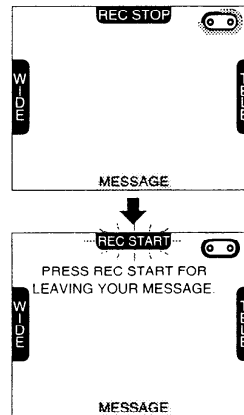

Note:

- When you want to stop recording before message recording stops automatically, press **■** on the  button to select "REC STOP". The screen fades out immediately and the VIEWCAM returns to Recording Standby mode.

Useful Features for Camera Recording

More Information on Self Recording

- The screen image is automatically inverted when the monitor rotation is between 140° and 200°. When the monitor is turned back to the normal position, the image returns to normal.
- During Self Recording mode, only the REC START/STOP, Zoom Wide and Telephoto buttons function on the remote control (see page 40).

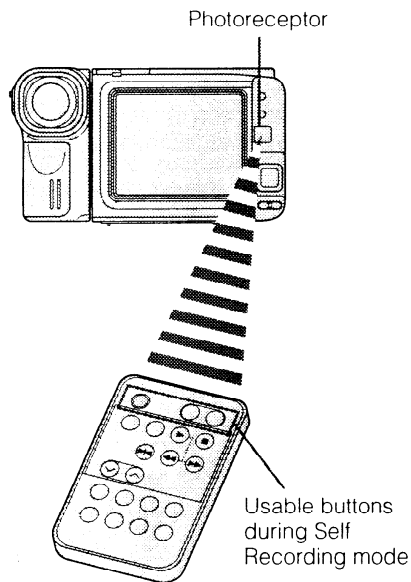

Useful Features for
Camera Recording

- In Self Recording mode, all standard warning indicators on the monitor are replaced by a flashing "⬇" indicator. To check the meaning of the warning, turn the monitor back to the normal position.

- In Self Recording mode, it is not possible to record using manual recording modes, change picture adjustments, display menus, record the date and time, or use the quick return and some of the other features.
- You can begin playback by setting the Power switch to VCR, even while the monitor is rotated 180°. The functions displayed on the monitor during normal playback still operate even though not displayed. (For example, ▶/⏪ on the Operation button [⏪] works as the Play button.) After recording in Self Recording mode, you can enjoy instant playback without having to re-rotate the monitor. In this case, the indicators will not be displayed on the monitor.
- If you set "SELF REC" to "NO CORRECT" on MENU-PAGE 1J (Camera mode), the image on the monitor screen will be displayed upside down.

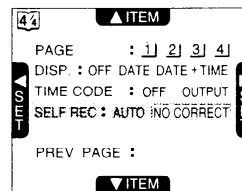

Manual Focus

The auto focus may not be able to focus on the subject in the situations shown in the chart on page 31. In such situations, set the VIEWCAM to Manual Focus mode and focus manually.

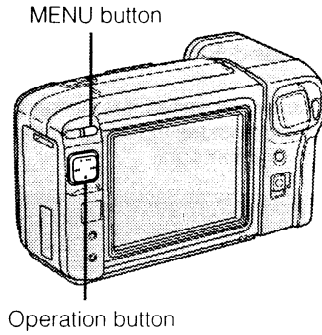

Setting the Manual Focus

- 1 Press the MENU button until **34** appears on the monitor (Camera mode). Press **■** on the Operation button (**⏏**) to select "FOCUS".

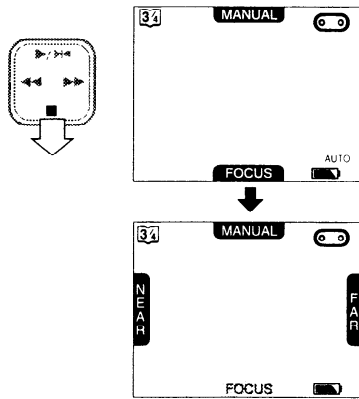

- 2 Press **◀** or **▶** on the **⏏** button to select "NEAR" or "FAR".

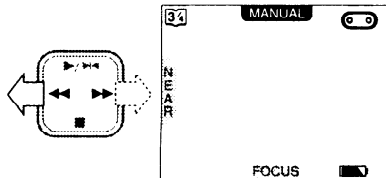

To Return to Auto Focus Mode

Press **■** on the **⏏** button to select "FOCUS" in step 1.

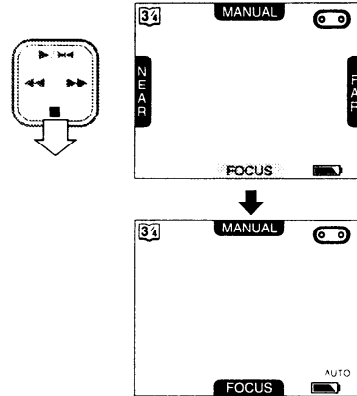

Notes:

- When recording in the Manual Focus mode, you may not be able to focus correctly if the subject is within approximately 1.5 m of the VIEWCAM. In such a case, shift the zoom control toward wide angle, and then try focusing again.
- If you focus on a subject in wide angle and then set the zoom to maximum, the subject may go out of focus. First focus on the subject at maximum zoom setting and then shoot at the desired zoom setting.
- If the lens is dirty or fogged, you may not be able to obtain correct focus.

Useful Features for
Camera Recording

Useful Features for Camera Recording

Setting the Shutter Speed

MENU button

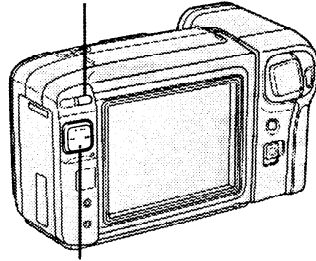

Operation button

- 1 Press the MENU button until **34** appears on the monitor (Camera mode). Press **▶/▶** on the Operation button (**3**) to select "MANUAL".

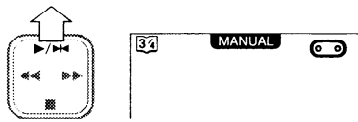

- 2 Select "CAMERA MODE" and then press **▶** to select "MANUAL".

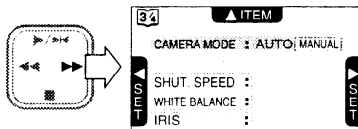

- 3 Press **■** to select "SHUT. SPEED".

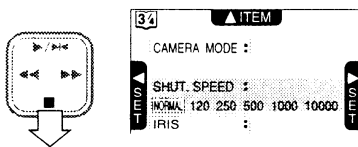

Note:

- Pressing **■** once again will select "WHITE BALANCE", not the "IRIS".

- 4 Press **▶▶** or **◀◀** to select the desired shutter speed.
 - You can select from 6 shutter speed settings from $1/50$ (NORMAL) to $1/10000$.

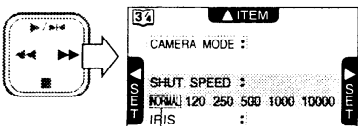

NORMAL ◀ 120 ▶ 250 ▶ 500 ▶ 1000 ▶ 10000

E 53

To Return to the Standard Shutter Speed

In step 4, press **◀◀** on the **3** button to select "NORMAL".

To reset the VIEWCAM to Full Auto mode, press **▶/▶** to select "CAMERA MODE" and then press **◀◀** to select "AUTO" in step 2.

Recommended Shutter Speeds

The faster the shutter speed, the darker the picture becomes. Select the most appropriate shutter speed for the ambient light.

Situation	Recommended shutter speed
<ul style="list-style-type: none"> • Recording sports action in bright daylight • Recording in bright daylight at a ski resort 	$1/10000$ sec. $1/1000$ sec.
<ul style="list-style-type: none"> • Recording outdoor sports on a somewhat cloudy day • Recording an outside scene through a car window (when you want to minimize blurs caused by camera shake) 	$1/1000$ sec. $1/250$ sec.
<ul style="list-style-type: none"> • When you want to reduce the light by half. Use as a substitute for an ND2 filter. 	$1/120$ sec.

Note on Recording under Fluorescent Lighting

If the picture on the monitor flickers when recording under fluorescent lighting, you may be able to compensate by changing the shutter speed to $1/120$ sec.

Notes:

- Using a fast shutter speed under fluorescent lighting will cause flickering in the picture and possibly periodic colour shifts
- Recording with a shutter speed higher than $1/50$ sec. (standard) tends to darken the picture. Record in bright locations when you use a high shutter speed.

White Balance Lock

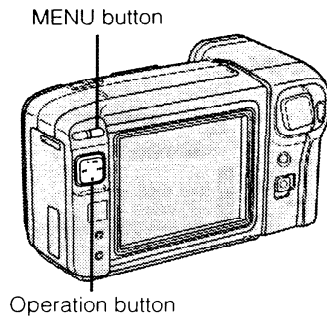

- 1 Press the MENU button until **34** appears on the monitor (Camera mode). Press **▶/▶** on the Operation button (**3**) to select "MANUAL".

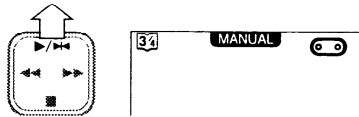

- 2 Select "CAMERA MODE" and then press **▶** to select "MANUAL".

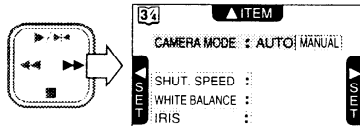

- 3 Press **■** to select "WHITE BALANCE".

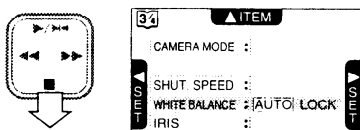

- 4 Aim the VIEWCAM at a solid white subject in the light.

- 5 Press **▶▶** to select "LOCK". The "LOCK" display flashes and the white balance is automatically locked. The "LOCK" display stops flashing when the locking procedure is completed.

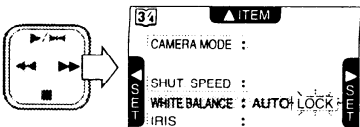

To Return to the Auto Mode

Perform steps 1 to 3, and press **◀◀** on the **3** button to select "AUTO".

To reset the VIEWCAM to Full Auto mode, press **▶/▶** to select "CAMERA MODE" and then press **◀◀** to select "AUTO" in step 2.

Notes:

- When recording with the white balance locked, if the light source changes or if you move from indoor to outdoor, or vice versa, the white balance may shift. Reset the white balance.
- Even after the white balance has been locked, white balance shifts may occur due to slight changes in illumination or depending on the subject.
- Do not move the VIEWCAM while "LOCK" is flashing in step 5.
- If the "LOCK" indicator does not stop flashing, set the white balance to "AUTO" and reset to "LOCK".

Manual Iris

The VIEWCAM is normally set to Auto Iris mode, which automatically chooses the optimal aperture. When there is too much contrast in brightness between the subject and background, however, you may not be able to record a clear image. Correct iris to adjust the aperture.

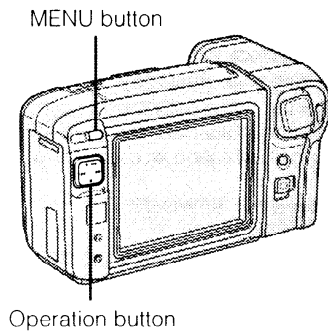

- 1 Press the MENU button until **34** appears on the monitor (Camera mode). Press **▶/▶** on the Operation button (**⏏**) to select "MANUAL".

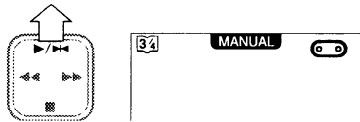

- 2 Select "CAMERA MODE" and then press **▶** to select "MANUAL".

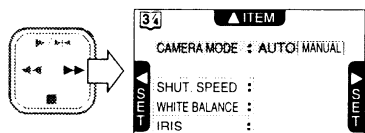

- 3 Press **■** to select "IRIS".

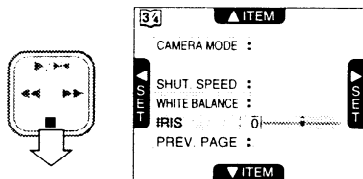

- 4 Press **◀** or **▶** to select the desired value setting.
 - The number shows the selected aperture value. The adjustable range is from -6 (least light) to +6 (most light)

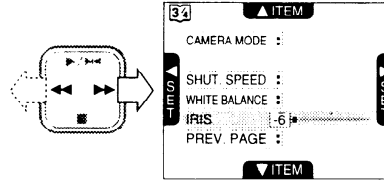

To Return to the Auto Mode

In step 4, press **◀** or **▶** on the **⏏** button to select "0".

To reset the VIEWCAM to Full Auto mode, press **▶/▶** to select "CAMERA MODE" and then press **◀** to select "AUTO" in step 2.

Strobe Recording

You can record strobe images (still pictures that capture continuous motion at 1/4 sec. intervals) of subjects with normal sound. You will find it useful when you want to produce a special effect while recording moving subjects such as your friends waving at you.

- 1 While the VIEWCAM is in Recording Standby mode, display the **24** screen (Camera mode) and press **▶/▶** on the Operation button (**⏏**) to select "STROBE".

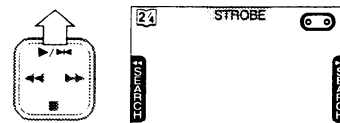

- Each time you press **▶/▶**, the recording mode switches between Normal and Strobe.

- 2 Press the REC START/STOP button to begin strobe recording.

- 3 To return to normal recording, press **▶/▶** on the **⏏** button to select "STROBE" again.

Note:

- The picture quality in this mode will be slightly lower than normal pictures.

Recording a Five-second Still Image (Snapshot)

You can record a still picture (snapshot) for about 5 seconds with normal sound simply by pressing the SNAP button.

This is useful when you want to record a scene like a photograph.

- 1 Refer to page 20 to display MENU-PAGE [3] (Camera mode). Press \blacksquare on the Operation button () to select "PHOTO SNAP" (1) and then press \leftarrow to select "SNAP" (2). Press the MFNU button to turn off the menu.

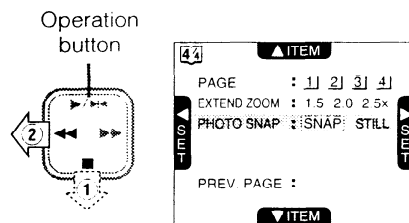

- 2 Press the SNAP button while the VIEWCAM is in Recording Standby mode.

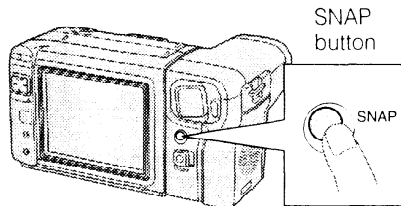

- 3 Press the REC START/STOP button.
 - The  indicator is displayed during snapshot recording.

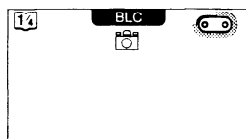

A still image of the subject will be recorded for about 5 seconds, then the VIEWCAM automatically returns to Recording Standby mode.

Notes:

- The image on the monitor will be frozen during snapshot recording.
- If the electronic high-speed shutter is used with the snapshot function, you can record a complete still image without any blurring.
- The picture quality of the snapshot is slightly lower than normal picture quality.

Still Recording

You can record still images of subjects with normal sound.

You will find it useful when you want to record a shot of a tourist information board during sightseeing.

- 1 Refer to page 20 to display MENU-PAGE [3] (Camera mode). Press \blacksquare on the Operation button () to select "PHOTO SNAP" (1) and then press \rightarrow to select "STILL" (2). Press the MENU button to turn off the menu.

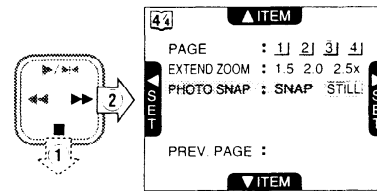

- 2 Press the SNAP button while the VIEWCAM is in Recording Standby mode.
- 3 Press the REC START/STOP button. A still image of the subject will be recorded.

Notes:

- Once the Still Recording mode is set, the VIEWCAM will remain in that mode until it is cancelled, even when switched between Recording mode and Recording Standby mode.
- The picture quality in this mode will be slightly lower than normal pictures.

Caution:

- Do not keep the VIEWCAM in Still Recording mode too long. The monitor may hold an after-image. Turn off the power and wait for a while. The monitor will return to normal.

To Pause Snapshot or Still Recording

Press the REC START/STOP button.

To Return to Normal Recording

Press the SNAP button to disengage the Snap/Still mode.

Lighting

For clear, good-quality recording, 500 to 100,000 lux is needed. Recording is also possible with less light, but the picture quality may suffer. Adequate lighting is also essential for correct white balance.

Brightness (Lux)	Situation (Lux)
100,000	Blue sky
	Clear day at noon (100,000)
10,000	Clear day at 10 am (65,000)
	Clear day at 3 pm (35,000)
	Cloudy day at noon (32,000)
	Cloudy day at 10 am (25,000)
1,000	Cloudy day, one hour after sunrise (2,000)
	Clear day, one hour before sunset (1,000)
	Fluorescent light near window (1,000)
100	Factory floor (700-800)
	Sales counter in department store (500-700)
	Bowling alley (500)
	Library (400-500)
	Office with fluorescent lighting (400-500)
	Fluorescent desk lamp (400)
	Flashlight at 1 m (250)
	Shop stairway (100)
10	During intermission at movie theatre (15-35)
	Cigarette lighter at 30 cm (15-20)
	Candles on birthday cake at 20 cm (10-15)
	Candlelight

Reference

Lighting is not only one of the most important areas in producing home videos, but also one of the most overlooked. Good lighting can often mean the difference between a great picture and a poor one. Lighting is also essential for correct white balance. In most outdoor, daytime scenes, natural lighting is adequate for home videos. Indoors, the situation becomes more complicated. Artificial lighting is required, and halogen lamps provide the most natural artificial light while maintaining a constant colour temperature over a long operating life. Good lighting is difficult to achieve. There are many problems waiting to catch the unwary. Simply mounting one light or several lights on either side of the VIEWCAM will only make your subject look flat and two-dimensional. To make a subject more interesting, use the lighting to model your subject and to add or create emphasis in a scene.

Colour Temperature (degrees Kelvin)	Situation	Colour	White Balance Range
10,000	Clear day	Blue	A U T O
9,000			
8,000	Cloudy day		
7,000	Rainy day		
6,500	Daylight fluorescent light		
6,000	Camera flashbulb		
5,500			
5,000	Blue photolamp	White	
4,500	White fluorescent light		
3,500	Off-white fluorescent light Tungsten photolamp		
3,200	Halogen lamp		
2,800	Tungsten lamp Iodine lamp	Yellow	
2,500	Acetylene lamp Kerosene lamp		
2,000	Candlelight	Red	

Notes:

- The figures in the charts are approximations.
- The auto white balance operates automatically within the range of "AUTO" shown in the chart. However, it will satisfactorily operate from 2,500 K up to 8,000 K, although the picture may take on a red or blue tint.

Lighting indicator ("LIGHT")

When the "LIGHT" indicator appears on the monitor, it means that there is not enough illumination for recording. Either move to a brighter location or increase the light. You can also correct the problem by manually setting the gain (see page 32).

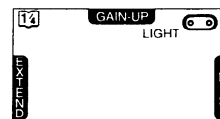

Connections and Editing

Using the A/V Pack

The supplied A/V pack lets you connect the VIEWCAM to other audiovisual equipment. Small and lightweight, it comes in handy when travelling or any time you are away from home.

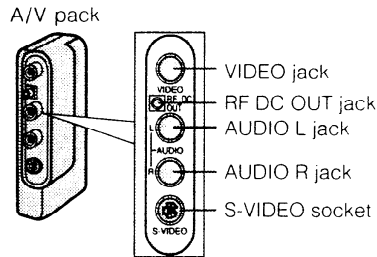

Attaching the A/V Pack

- 1 Remove the A/V pack terminal cover of the VIEWCAM as shown below.

Note:

- Be careful not to lose the cover once it is removed

- 2 Align the projections on the A/V pack with the openings on the VIEWCAM's mounting panel, insert the A/V pack as shown, then push the A/V pack firmly against the mounting panel until it clicks into place.

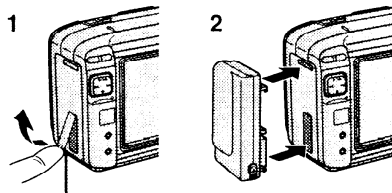

A/V pack terminal cover

Detaching the A/V Pack

Slide the EJECT release on the A/V pack in the direction of the arrow, and then pull the A/V pack straight out.

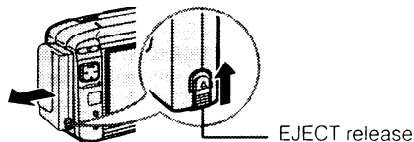

Caution:

- Do not use the A/V pack as a handle; it will cause malfunctions.

Connections for Playback on a TV with Audio/Video Jacks

Although you can enjoy playback on the VIEWCAM's LCD monitor, you can also watch played-back tapes on your TV screen.

- Connect the VIEWCAM to your TV with the supplied audio/video cable, as shown.

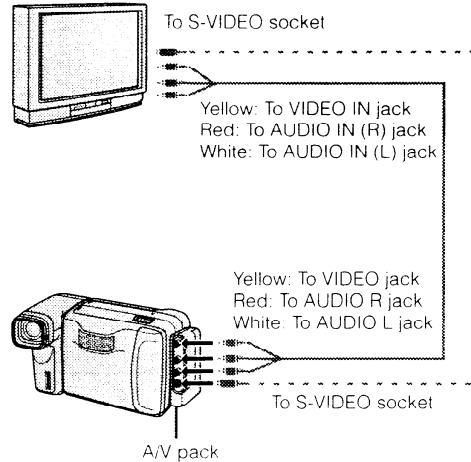

Caution:

- Make sure that the VIEWCAM, TV and other equipment to be connected have been turned off before you make connections. Making connections with any of the components left turned on may cause picture noise or malfunction.

Connection to TV without Audio/Video Jacks

To connect the VIEWCAM to a TV which does not have audio/video jacks, use the supplied A/V pack and the optional RF converter **VR-H30RF for Southeast Asia and the Middle East** or **VR-X30RF for Australia and New Zealand**.

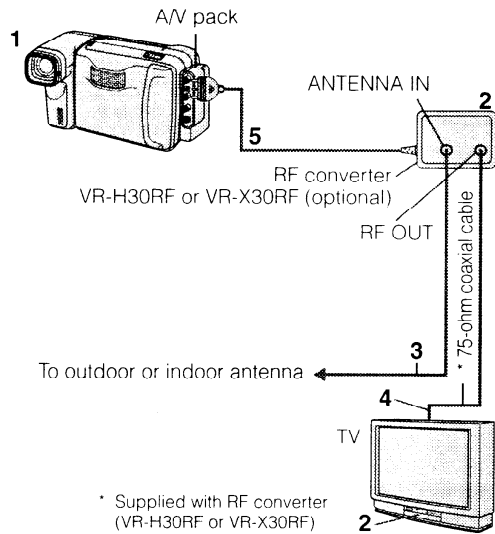

1 Attach the A/V pack to the VIEWCAM (see page 58).

2 Southeast Asia and Middle East:

The channel adjuster on the RF converter is set to CH36. If CH36 is used in your area, set it to a different channel. Set the TV tuner to the same channel as that selected on the RF converter.

- If UHF channel 36 is an active broadcast channel in your area, any non-broadcast channel from UHF channel 30 to 39 can be selected for viewing the VIEWCAM's output on TV.

Adjust the RF converter's output channel adjuster to any of those channels (UHF30-39), and tune your TV to the same channel.

Set the I/G selector on the RF converter according to the TV system in your area.

- "I" refers to system PAL I and the I/G selector should be in this position for use in Hong Kong, South Africa, and U.K. "G" refers to system PAL G for use in other PAL areas.

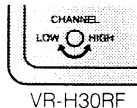

Australia and New Zealand:

To view the output from your VIEWCAM on the TV, you must select an unused channel on your TV and tune it to the output of the RF converter (factory preset to channel 0).

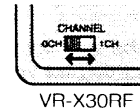

- Unplug the antenna cable from the TV and plug it into the ANTENNA IN terminal on the RF converter.
- Plug the 75-ohm coaxial cable into RF OUT terminal on the RF converter and the 75-ohm coaxial antenna terminal on the TV.
- Plug the RF converter cable into the AUDIO, VIDEO, and RF DC OUT jacks on the AV pack.

If your TV's antenna input is connected to a VCR

Disconnect the cable between the TV and VCR, and insert the RF converter between them.

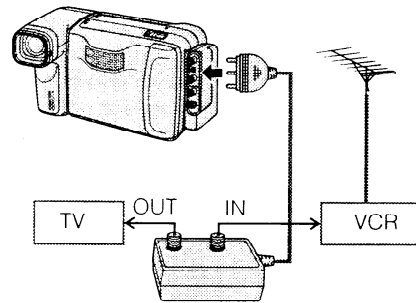

Cautions:

- Use only the RF converter (VR-H30RF or VR-X30RF [optional]) corresponding to your region. VR-H30RF: For Southeast Asia and the Middle East. VR-X30RF: For Australia and New Zealand.
- The RF converter is a sealed unit. Do not attempt to open or modify it. Do not damage, drop or subject the unit to vibration.
- Unplug the RF converter during lightning storms.

Notes:

- To resume normal TV operation, set the VIEWCAM's Power switch to OFF, or unplug the RF converter cable from the A/V pack if it is still attached to the VIEWCAM.
- The picture may be disturbed during video search or still picture playback. This does not imply a defect in the VIEWCAM.

Connection to TV via VCR

- 1 Connect the A/V pack to your VCR with the supplied audio/video cable.
- 2 Set the VCR to its "AV" or "LINE" input channel. Operate the TV as you normally do to see the signal from the VCR. (See the operation manuals for your TV and VCR.)
 - If your VCR has an S-video input socket, connect it to the A/V pack's S-VIDEO socket with the supplied S-video cable.

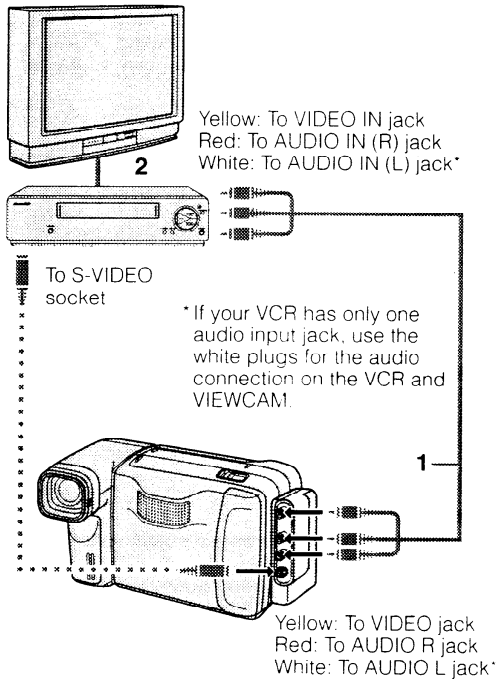

About the S-video socket

S-video sockets are used to pass the chroma (colour) and luminance (brightness) components of video signals separately. They serve to improve the picture quality in both recording and playback.

Watching Played-back Tapes on a TV

- 1 Turn on your TV and set it to its "AV" or "VIDEO" channel. (See the operation manual for your TV.)
- 2 Turn on the VIEWCAM in the VCR mode, and begin tape playback as you normally do (see page 41).

Note:

- When the VIEWCAM is connected to a TV for playback, the picture on the TV screen may flicker if the volume on the VIEWCAM is set to maximum. Should this occur, turn the volume down (see page 41).

Editing

Video editing lets you refine your videos by removing unwanted sequences from your tape, or transposing one sequence with another. This VIEWCAM lets you monitor the source programme on the built-in LCD monitor without having to connect it to an external TV or video monitor.

Connect the VIEWCAM to a VCR with the supplied A/V pack and audio/video cable.

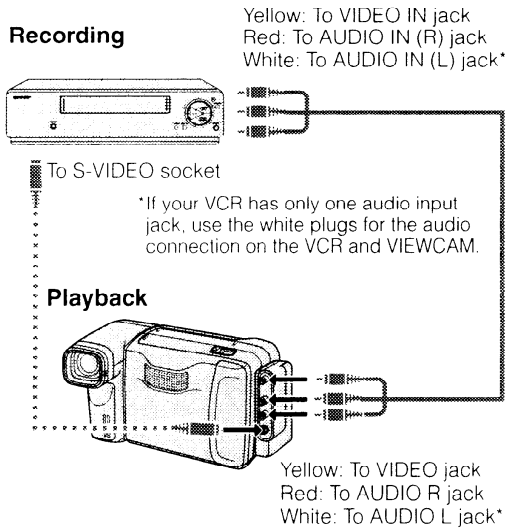

Note:

- If your VCR has an S-video input socket, connect it to the S-VIDEO socket on the A/V pack with the supplied S-video cable.

Cutting Unwanted Sequences

- 1 Play back the tape to be edited, and locate the beginning and end of the sequence you wish to cut. Write down the time code or the tape counter readings at the beginning and end of that sequence (see pages 45 and 46). Then rewind the tape to the beginning of the portion that you wish to keep.
- 2 Load a blank tape cassette into the recording VCR.
- 3 Set the Power switch to VCR. Press ►/▶ on the Operation button (E) to select "PLAY" and press the VCR's REC (Record) button at the same time.
- 4 Press the VCR's Pause/Still button to pause recording when the source tape reaches the beginning of the sequence to be cut.
- 5 Press the VCR's Pause/Still (or Record) button to resume recording when the source tape reaches the end of the sequence to be cut.

To stop editing

Press ■ on the E button to select "STOP" on the VCR screen and press the STOP button on the VCR.

Notes:

- Some of the transitions between edited sequences may be slightly off.
- The picture may be disturbed during video search or still picture playback. This does not imply a defect in the VIEWCAM.
- The time code display is convenient when cutting unwanted sequences (see page 45).

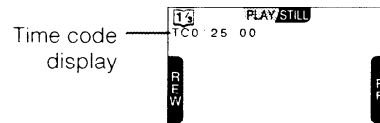

We recommend that you set the "TIME CODE" menu item to "OFF". If you set it to "OUTPUT", the time code will be recorded along with the edited sequences.

Fluorescent Lamp Backlight

The fluorescent lamp backlight used in this VIEWCAM will eventually need replacing. If you continue to use the VIEWCAM when the fluorescent lamp has almost reached the end of its service life, the "REPLACE THE LAMP." indicator will be displayed on the monitor for approximately one minute. When this occurs, purchase a replacement lamp (KLMPV0018TAZZ) from your dealer or a SHARP Full Line Parts Distributor, and replace the old lamp.

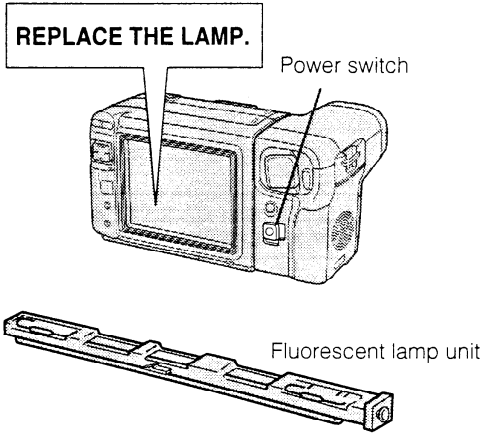

Replacing the Fluorescent Lamp Backlight

- 1 Set the Power switch to OFF to turn off the VIEWCAM, and wait about 15 minutes for the lamp unit to cool down.
- 2 Rotate the camera module of the VIEWCAM halfway forward as shown.
- 3 Remove the lamp compartment cover: insert a pointed object such as the point of a pen into the opening above the cover, push the cover release "⏏" down, and then pull off the cover.

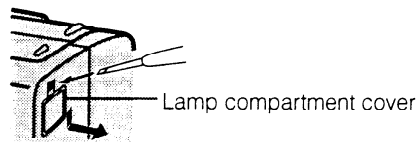
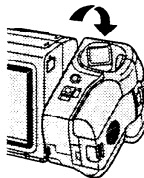
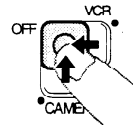

- 4 Carefully hold the end (white knob) of the lamp unit with tweezers, and pull it out.

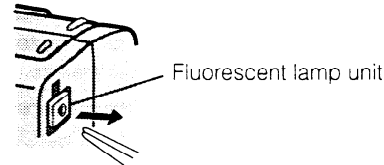

- 5 Insert the replacement lamp unit into the compartment. See note below.

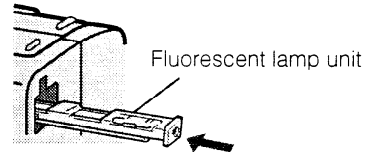

- 6 Replace the fluorescent lamp compartment cover.



Notes:

- In step 5 above, be sure to insert the replacement fluorescent lamp straight in, in the direction of the arrow. Do not press diagonally as it may cause contact failure.
- The fluorescent light may flicker when first turned on. Should this occur, turn off the VIEWCAM, and then turn it on again.
- When used in cold locations, the fluorescent lamp may lose some of its brightness.
- Remove the battery pack before replacing the fluorescent lamp.

Caution:

- The fluorescent lamp is hot during and immediately after use of the VIEWCAM. Wait at least 15 minutes after turning the power off before attempting to change the lamp, to allow time for it to cool down. Attempting to change the lamp unit while it is still hot may result in burns or other injuries.

Before Requesting Service

Before calling for service, please check the following troubleshooting table.

	Symptom	Possible cause	Suggested solution
Power	No power.	• Power source is not properly connected.	• Connect power source properly. (pp. 15-17)
		• Battery pack is not charged.	• Charge battery pack sufficiently. (p. 14)
		• Dew in VIEWCAM.	• Wait until dew dries. (p. 6)
		• Safety function is in effect.	• Set Power switch to OFF and remove battery pack; wait for two seconds, then re-install battery pack and turn on power. (p. 15)
Recording	REC START/STOP button does not work.	• Erasure protect tab on video cassette is open.	• Close tab or use a new cassette. (p. 9)
	Power suddenly turns off.	• VIEWCAM left in Recording Standby mode for five minutes.	• Set Power switch to OFF and then back to CAMERA.
	Monitor picture is hard to see.	• Inappropriate picture adjustments.	• Adjust picture. (p. 27)
	Auto focus does not work.	• Manual Focus mode is engaged.	• Set to Auto Focus mode. (p. 52)
		• Zoom used on close subject.	• Zoom out on subject. (p. 30)
		• Subject has little contrast in brightness, or is full of horizontal or vertical stripes.	• Focus manually. (p. 52)
	Bright subject produces wide vertical lines.	• Occurs when shooting subject with strong contrast to the background. Does not indicate a malfunction.	—
	No audio from speaker when recording.	• Speaker does not work during Camera mode. (Volume control in Camera mode only affects earphone volume.)	—
Automatically zooms out without operating Zoom buttons.	• VIEWCAM is unable to focus when zooming in on subject within 1.5 m, and automatically zooms out until it focuses on subject.	• Zoom out. (p. 30)	
	• No subject in the field of view.	• Direct lens to some subject, or set zoom to widest angle before shooting. (p. 30)	
Playback	Tape stops midway through rewind or fast forward.	• Counter is in memory mode.	• Disengage memory mode. (p. 46)
	No image appears on connected TV screen.	• Video input channel on TV or TV channel is not selected properly.	• Select video input channel on TV or TV channel properly. (pp. 58-60)
		• A/V cable is not properly connected.	• Connect A/V cable properly. (pp. 58-60)
	• A/V pack is not properly connected.	• Connect A/V pack properly. (p. 58)	

Others

	Symptom	Possible cause	Suggested solution
Playback	Cannot play back, rewind or fast forward tape.	• Tape already wound or rewound completely.	• Rewind or fast forward tape to desired point. (p. 41)
	During playback, mosaic patterns appear or picture disappears.	• Dirty video heads.	• Call for service.
		• Old or worn tape.	• Use a new video cassette.
Recording & Playback	No power in VCR or Camera mode.	• Depleted battery pack.	• Use fully charged battery pack. (p. 14)
		• AC adaptor cord removed from power outlet.	• Plug AC adaptor cord into power outlet. (p. 16)
	Cassette will not eject.	• Power source is not properly connected.	• Connect power source properly. (pp. 15-17)
		• Battery pack is not charged.	• Charge battery pack sufficiently. (p. 14)
		• VIEWCAM is recording.	• Stop tape and try again.
	No buttons operate.	• Dew in VIEWCAM.	• Wait until dew dries. (p. 6)
No image on monitor.	• Backlight has been turned off.	• Press MODE DISPLAY button, or set Power switch to OFF and then back to CAMERA or VCR. (p. 43)	
	• Fluorescent lamp is burned out.	• Replace with new fluorescent lamp unit. (p. 62)	
Cannot edit to connected VCR.	• A/V or S-video cable is not properly connected.	• Connect A/V or S-video cable properly. (p. 58)	
	• A/V pack is not properly connected.	• Connect A/V pack properly. (p. 58)	
Lens makes rattling sound when VIEWCAM is moved in VCR mode or with power off.	• Does not indicate a malfunction.		
Remote control does not function.	• "REMOTE" menu item is set to "OFF".	• Set "REMOTE" menu item to "ON". (p. 40)	
	• Remote control lithium battery has run down.	• Replace remote control lithium battery with a new one. (p. 13)	
	• Remote control used beyond operating range.	• Use remote control within operating range. (p. 40)	
	• Intense daylight falling on VIEWCAM's photoreceptor.	• Protect photoreceptor from exposure to intense daylight. (p. 40)	
	• Obstacle between remote control and VIEWCAM's photoreceptor.	• Remove obstacle or use remote control from different angle. (p. 40)	

Notes:

- This unit is equipped with a microprocessor. Its performance could be adversely affected by external electrical noise or interference. If this should happen, turn off the power and disconnect the unit from any power sources, including lithium batteries, etc. Then reconnect the power sources (to resume operation).
- If the characters displayed on the monitor screen appear to malfunction, disconnect the power source and remove the lithium battery, then reconnect the power source, insert the lithium battery, and turn the power on again. The characters on the monitor should be normal. Set the date and time, then resume operation.

Specifications

Signal System: PAL standard
Recording System: 2 rotary heads, helical scanning system
Cassette: Digital VCR Mini DV video cassette
Recording/Playback Time: 60 minutes (DVM60)
Tape Speed: 18.831 mm/second
Pickup Device: 1/4" (6.4 mm, effective size: 4.5 mm) CCD image sensor (with approx. 470,000 pixels including optical black)
Lens: 12× power zoom lens (F1.8, f=4.2–50.4 mm), full-range auto focus
Lens Filter Diameter: 37 mm
Monitor: 4" (10.1 cm)—full-colour LCD screen (TFT active matrix)
Microphone: Electret stereo microphone
Colour Temperature Compensation: Auto white balance with white balance lock
Minimum Illumination: 6 lux* (with gain-up, and digital zoom off)
Video Output Level: 1.0 Vp-p 75-ohm unbalanced
Audio Output Level: –8 dBs, impedance less than 2.2 kohms
Speaker Output: 300 mW
External Microphone Input: 3.5 mm diameter mini-plug, –66 dBs, output impedance 6.8 kohms, DC 4 V, for plug-in-power microphone use
Power Requirement: DC 3.6 V
Power Consumption: 8.5 W (during camera recording in full auto mode with zoom motor off, backlight in normal mode)
Operating Temperature: 0°C to +40°C
Operating Humidity: 30% to 80%
Storage Temperature: –20°C to +60°C
Dimensions (approx.): 181 mm (W) × 99 mm (H) × 88 mm (D)
Weight (approx.): 690 g (without battery pack, lithium battery, video cassette)

AC Adaptor/Battery Charger

Power Requirement: AC 110–240 V, 50/60 Hz
DC Output: 4.5 V
Power Consumption: 25 W
Dimensions (approx.): 120 mm (W) × 51 mm (H) × 101.5 mm (D)
Weight (approx.): For Asia/Middle East (UADP-0233 TAZZ): 394g
For Hong Kong (UADP-0219 TAZZ): 460g
For Australia/New Zealand (UADP-0216 TAZZ): 420g
For Russia (UADP-0235 TAZZ): 394g

Specifications are subject to change without notice.

*Minimum illumination: Since there is no widely accepted testing procedure for determining minimum illumination capability, lux ratings are comparable only between models from the same manufacturer.

Easy Menu Reference Chart

Once you become familiar with the menu system, use this chart to guide yourself through functions and setups.

Camera mode

Function
page

Functions

1/4

BLC/GAIN-UP
DIS
FADE
EXTEND

2/4

STROBE
SEARCH ►►
RETURN
SEARCH ◀◀

3/4

MANUAL FOCUS CAMERA MODE PREV. PAGE AUTO MANUAL
SHUT. SPEED
WHITE BALANCE
IRIS
PREV. PAGE

Easy Menu Reference Chart

(Camera mode)

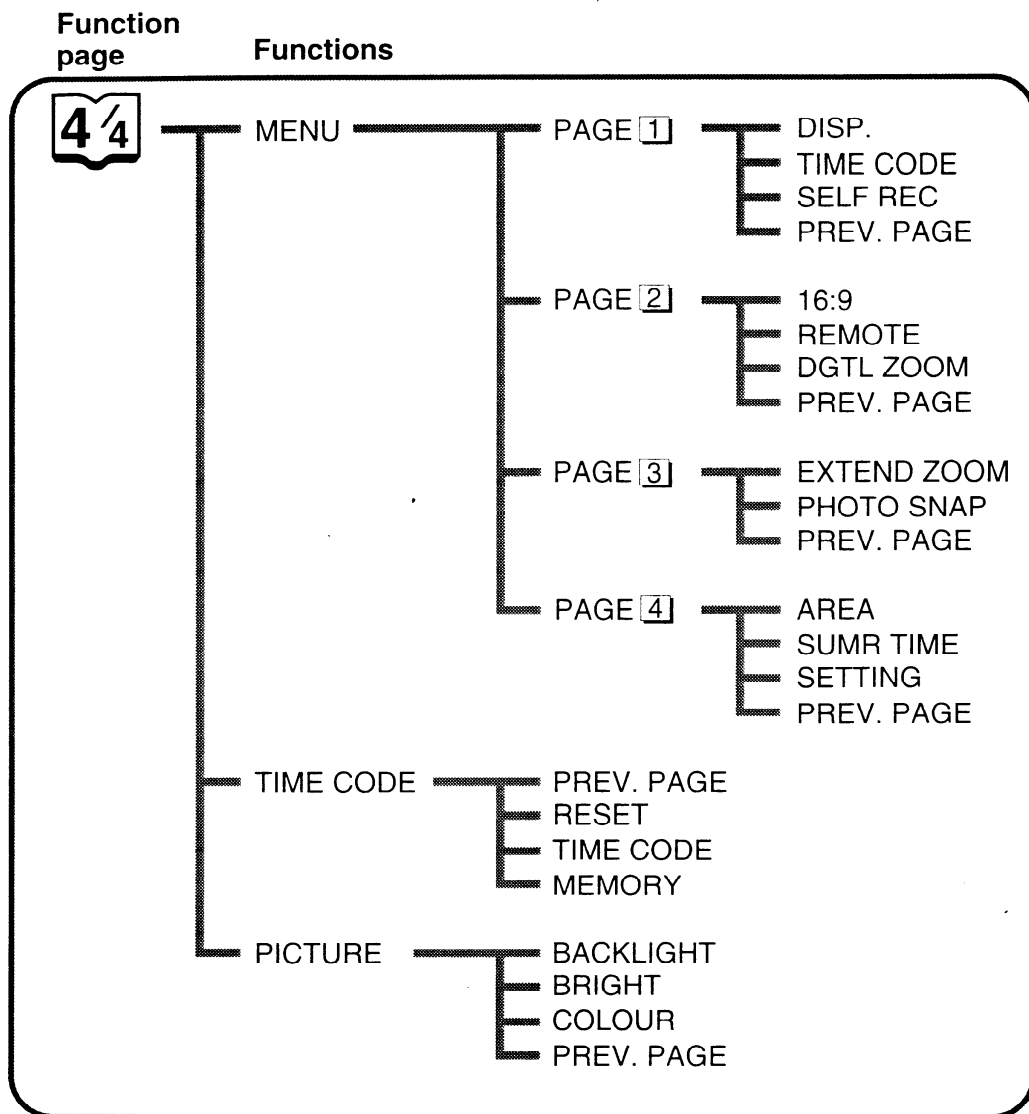

Others

VCR mode

Function
page

Functions

1/3

PLAY/STILL
FF
STOP
REW

2/3

SEARCH
PICTURE

BACKLIGHT
BRIGHT
COLOUR
PREV. PAGE

3/3

MENU

DISP.
TIME CODE
REMOTE
PREV. PAGE

TIME CODE

PREV. PAGE
RESET
TIME CODE
MEMORY

Others