

SHARP®

**OPERATION MANUAL
BEDIENUNGSANLEITUNG
MODE D'EMPLOI
BRUKSANVISNING
MANUALE DI ISTRUZIONI
MANUAL DE MANEJO
GEBRUIKSAANWIJZING
MANUAL DE OPERAÇÃO**

- Before using this Camcorder, read page 2.
- Vor der Verwendung des Camcorders die Seite 2 lesen.
- Avant d'employer cet appareil, veuillez lire la page 2 de ce mode d'emploi.
- Läs sidan 2 innan denna kamera-bandspelare används.
- Prima di usare questo camcorder, leggete pag. 2.
- Lea la página 2 antes de utilizar esta videocámara.
- Alvorens deze gebruiksaanwijzing door te lozen, zie eerst bladzijde 2.
- Antes de usar esta Videocámara, leia a página 2.

Zoom 8

VHS-C CAMCORDER
PAL

HQ HIGH QUALITY

MODEL

VL-C7200S

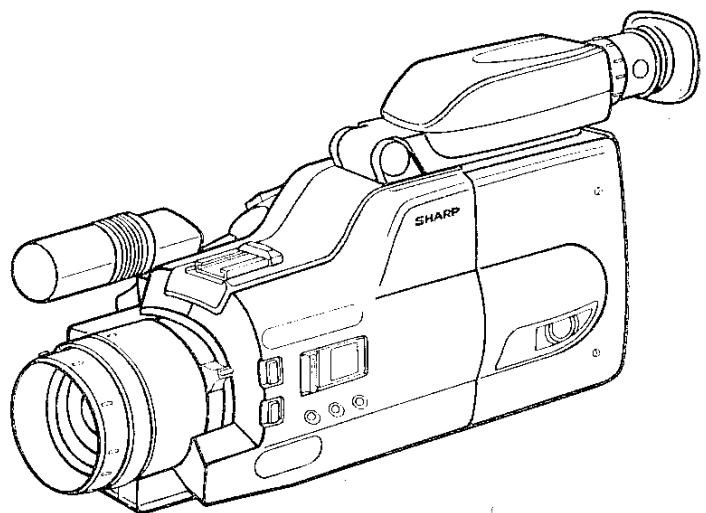

This apparatus complies with the requirements of EN 55014, 02.1987.

Dieses Gerät stimmt mit den Bedingungen der EN 55014, 02.1987 überein.

Cet appareil répond aux spécifications de la EN 55014, 02.1987.

Dit apparaat voldoet aan de vereiste EN 55014, 02.1987.

Apparatet opfylder kravene i EN 55014, 02.1987.

Questo apparecchio è stato prodotto in conformità alle EN 55014, 02.1987.

Este aparato cumple las especificaciones de la EN 55014, 02.1987.

Este aparelho responde às especificações da EN 55014, 02.1987.

Αύτή ἡ συσκευή τηρεῖ τίς προδιαγραφές τῆς EN 55014, 02.1987.

OPERATION MANUAL

ENGLISH

WARNING:

**TO PREVENT SHOCK HAZARD,
DO NOT EXPOSE THIS APPLI-
ANCE TO RAIN OR MOISTURE.**

This equipment should be used with DC 9.6V
⎓ only or recommended AC adaptor.

CAUTION:

To prevent electric shocks and fire hazards, do
NOT use any other power source.

CAUTION:

To prevent shock, do not open the cabinet. No user
serviceable parts inside. Refer servicing to qualified
dealer or service centre.

Congratulations on a Wise Decision!

With so many brands available, the choice was difficult.

But after enjoying the top quality and high performance of this Sharp Camcorder, you'll know you were right.

The purchase of this Camcorder will further enhance your enjoyment of television viewing. Before operating, please read this operation manual to get the most out of your Sharp Camcorder. Also, please save it for future reference, since it will be useful if you have any trouble during operation.

FEATURES

- 1** Colour Viewfinder
- 2** 1/2" CCD image sensor with F1.6, 8× variable speed zoom with macro focus.
- 3** Full Auto Camera Recording System
— Automatic Focus, Iris, and White Balance
- 4** 1/10,000, 1/2,000, 1/500, 1/100 of a sec. variable range, high speed shutter.
- 5** Ultra low light recording down to 3 lux (with Gain-up function)
- 6** Intelligent Auto Iris for shooting backlit subjects
- 7** Flying erase head and camera search
- 8** Self timer for Camera Recording
- 9** 3-way power source with AC, battery, and car battery

Important

Audio-visual material may consist of copyrighted works which must not be recorded without the authority of the owner of the copyright. Please refer to relevant laws in your country.

Power Supply

This unit can be operated by connecting it to either the AC adaptor, battery pack or optional car battery adaptor/charger. The AC adaptor incorporates the AUTO VOLTAGE (AC 110-240V, 50/60Hz) function.

CONTENTS

FEATURES	1	LCD DISPLAY AND	
PRECAUTIONS	2	VIEWFINDER INFORMATION	19
MAJOR OPERATING COMPONENTS AND		AUTO DATE/TIME FUNCTION	20
THEIR FUNCTIONS	4	ASSEMBLE RECORDING	21
PREPARATIONS	7	REPLACING THE BATTERY PACK	
INSTALLING THE LITHIUM BATTERY	7	WHILE RECORDING	21
SETTING THE DATE/TIME	7	AUTO POWER OFF	21
ATTACHING AND DETACHING		PLAYBACK	22
THE BATTERY PACK	8	PLAYBACK IN THE VIEWFINDER	22
ATTACHING THE SHOULDER STRAP	8	TRACKING ADJUSTMENT	22
INSERTING AND REMOVING A CASSETTE	9	FORWARD/REVERSE SEARCH AND STILL	23
ADJUSTING THE GRIP STRAP	9	COUNTER MEMORY FEATURE	24
USE OF AN EXTERNAL MICROPHONE	10	CONNECTION TO TV	25
USING THE COLOUR VIEWFINDER	10	CONNECTION TO TV WITH AV TERMINALS	26
POWER SUPPLY SYSTEM	11	RECORDING TO ANOTHER VCR	27
USING THE AC ADAPTOR/ BATTERY CHARGER	11	EDIT CONTROL	27
CHARGING THE BATTERY PACK	12	USING THE CASSETTE ADAPTOR (OPTIONAL ACCESSORY)	28
USING THE CAR BATTERY ADAPTOR/ CHARGER (OPTIONAL ACCESSORY)	12	ADVANCED OPERATION	30
USING THE BATTERY PACK	13	MANUAL FOCUS	30
CAMERA RECORDING	14	WHITE BALANCE	30
CAMERA RECORDING	14	BACKLIGHT COMPENSATION	31
FULL AUTO SYSTEM	16	GAIN-UP	31
REC REVIEW	17	SELF TIMER RECORDING	31
CAMERA SEARCH	17	HIGH SPEED SHUTTER	32
POWER ZOOM		MACRO SHOTS	33
(WIDE/TELEPHOTO CONTROL)	17	FADE IN & OUT	33
LAP TIME FUNCTION	18	LIGHTING	34
		BEFORE REQUESTING SERVICE	35
		SPECIFICATIONS	36

PRECAUTIONS

READ THE SAFETY AND OPERATING INSTRUCTIONS before operating this Camcorder. FOLLOW INSTRUCTIONS AND HEED ALL WARNINGS on this Camcorder and in this manual.

DEW FORMATION

What is "dew formation?"

When you pour cold beer into a glass, dew forms on the glass. This clinging of water drops is called dew formation.



When dew forms in your Camcorder.

Dew will gradually form on the head drum of your Camcorder and make the video tape stick to the head. This causes damage both to the head and the tape. When dew formation occurs, recording and playback may not function properly.

Dew is likely to form in the following circumstances:

- When moving the Camcorder from a cold place to a warm place.
- When placing the Camcorder in a cold room which is then heated rapidly.
- When moving the Camcorder outdoors from an air conditioned room.
- When placing the Camcorder in the direct path of air blowing from an air conditioner.
- And when placing the Camcorder in a humid room.

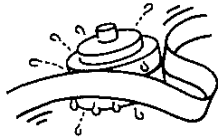

How to prevent trouble due to dew formation.

When using the Camcorder in a place where dew formation is likely to occur, allow the Camcorder and the video tape to acclimatize to the surroundings for about one hour.

For example, when bringing the Camcorder indoors after skiing, first put it in a plastic bag and allow it to adapt to room conditions for some period of time.

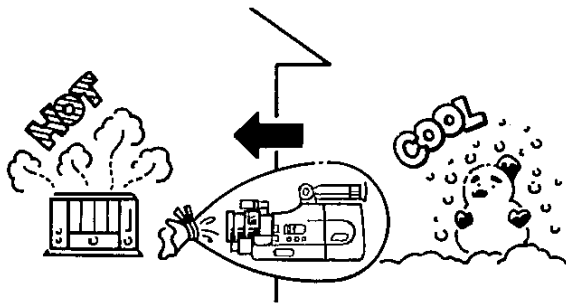

- ① Make sure there is enough air in the plastic bag containing the Camcorder.
- ② Remove the bag when the air temperature inside it reaches the temperature of the surroundings.

"Dew" warning feature

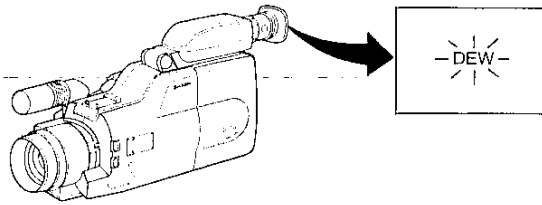

When dew forms on the head drum, the dew warning indicator appears in the viewfinder. After ten seconds, the power will automatically turn off.

Notes

- When "DEW" appears, eject the video tape and leave it out for several hours to adapt it to the surroundings.
- Since dew forms gradually, it may take 10 to 15 minutes before "DEW" appears on the display.
- To use the Camcorder again, turn the power on after waiting for several hours and make sure that "DEW" has disappeared.

Before actual recording, be sure to test record, checking that both the picture and the sound are being recorded properly. The picture can be easily checked by using "REC REVIEW".

How to continually maintain good recording.

If used in a variety of places, eventually your Camcorder may not function properly due to accumulation of dirt on the head drum. Please pay special attention to the following points when using your Camcorder.

- ① Dew formation on the head drum.
- ② The video tape becomes worn:
Using a damaged or soiled video tape may also soil the head drum, causing the picture to be blurred or nothing to be recorded on the video tape. Do not use such a video tape.
- ③ Using the Camcorder in a humid or a dusty place:
Use in extremely humid or dusty places may cause damage to your Camcorder.

When the video heads are dirty.

Using the Camcorder when the video head is dirty may cause the head to clog, producing noise on the recorded image or preventing the image from being recorded at all.

Under such circumstances, contact the nearest SHARP service centre or your dealer for further advice.

For safety, strictly observe the following

- Do not open the case.
- Take care to avoid flammables or other liquids and metal objects from entering the unit. Should this happen, switch the power off and have the Camcorder checked by qualified personnel.
- Do not disassemble or attempt to modify the unit.
- Do not operate the Camcorder during lightning storms. Unplug power cables of any connected equipment.

Avoid using the Camcorder under the following conditions

- Places of extreme humidity or excessive dust.
- Near electrical appliances generating strong magnetic fields (fluorescent lights, televisions, speakers).
- Steamy or sooty places such as near a cooking stove.
- Excessive mechanical shock or vibration.
- Extremely hot locations such as near heating.
- Wet locations, such as near swimming pools, bathtubs and the like.

Do not expose the Camcorder to extremely high or low temperatures for long periods

- Never leave this Camcorder in direct sunlight, in a closed car during summer or near a heater — this will most likely deform the exterior and damage the internal parts of the Camcorder.
- Do not store the Camcorder in places over 60°C.
- Do not use the Camcorder in places over 40°C.
- Do not use the Camcorder in places below 0°C.
- Do not use the Camcorder in humid places over 80% RH.

Store the Camcorder in a location that stays between -20°C and 60°C.

Take extra care when recording outdoors

- Do not drop or allow it to strike any hard or rough surface. Protect from damage during transportation.
- Prevent the Camcorder from getting wet.
- At the beach, keep away from salt water or spray and prevent sand from entering the Camcorder.
- Avoid aiming the lens at extremely bright objects like the sun or other strong lights.
- **Do not direct the viewfinder eyepiece at the sun.**
- Stop using the Camcorder during lightning storms.

BEFORE DISCONNECTING A POWER SOURCE, ALWAYS SLIDE THE OPERATE SWITCH TO OFF — THE OPERATE INDICATOR WILL GO OUT.

Handling the Camcorder

- Protect the microphone from damage.
- Keep the Camcorder horizontal during use, otherwise the tape may become slack and be damaged.
- **Do not carry the Camcorder by the viewfinder. Loop the strap over your arm — should the Camcorder accidentally slip out of your hand, you will avoid damaging it.**

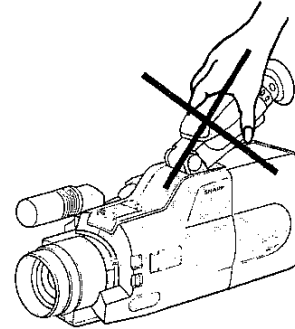

- Cap the lens after use. Remember to switch the power off.
- Do not touch the focus ring while using Autofocus.
- Before attaching any filter to the lens, switch to manual focus or switch the power off and remove the lens hood.

Cleaning the Camcorder

- Detach the battery pack or disconnect the power before cleaning the Camcorder.
- Remove dust with a soft cloth. Use a soft cloth moistened with mild detergent to remove persistent dirt.
- Do not use strong cleaning agents such as PETROL, thinner or alcohol — they may damage the exterior.
- Keep the lens and viewfinder clean. Clean the lens by first blowing it free of dust, then gently wipe it with a soft brush or lens cleaning paper moistened with lens cleaning fluid.

MAJOR OPERATING COMPONENTS AND THEIR FUNCTIONS

FRONT VIEW

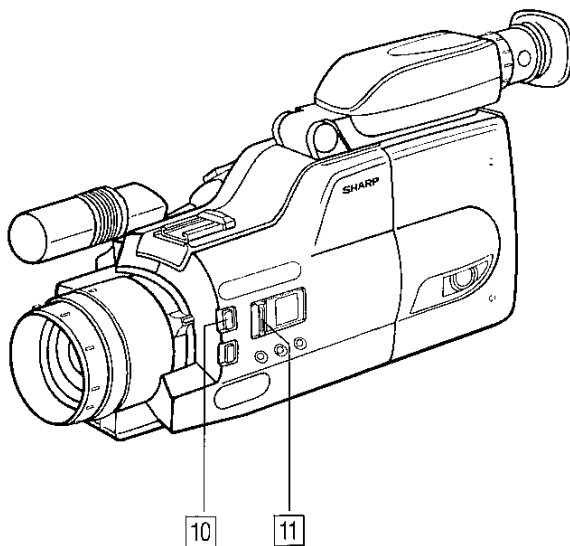
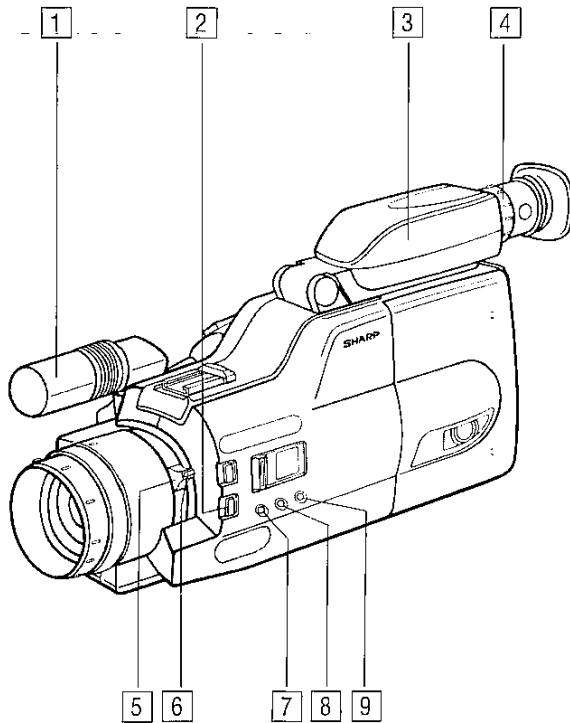

For details on the use of each control, refer to the page indicated in the brackets.

- 1 Microphone**
- 2 BLC (Back Light Compensation)/GAIN-UP button**
If the subject is darker than the background, the recorded subject may appear too dark and undefined. If this is the case, push this button for "BLC". When "LIGHT" is displayed in the viewfinder, the gain-up mode is engaged and the screen becomes brighter when this button is pressed.
- 3 Colour Viewfinder/Monitor**
Displays the photographic subject in full colour. Also functions as a convenient colour monitor for playback of recorded material.
- 4 Diopter adjustment**
Use this control to adjust the viewfinder focus to your eyesight.
- 5 Zoom lever**
Use this lever to manually zoom in and out on your subject.
- 6 Macro button**
Use this control for shooting subjects positioned less than 1.1 m from the Camcorder. (Autofocus does not function at this distance.) Press the MACRO button continuously while moving the Zoom lever to the "MACRO" position for focusing.
- 7 AUTO/MANUAL FOCUS Select button**
Set to "AUTO", the Camcorder will automatically focus on the subject even if it is moving. (Remember to use the macro focus feature to focus on subjects less than 1.1 m away.)
If, however, Autofocus does not function because of the prevailing shooting conditions, set this switch to "MANUAL" and focus manually.
- 8 WHITE BALANCE button [30]**
Use this button to lock the white balance.
- 9 SHUTTER SPEED Select button [32]**
For a clear image replay of high speed motion in still mode (or slow mode with a regular VHS VCR).
- 10 FADE IN/OUT button [33]**
- 11 FULL AUTO switch [16]**

REAR VIEW

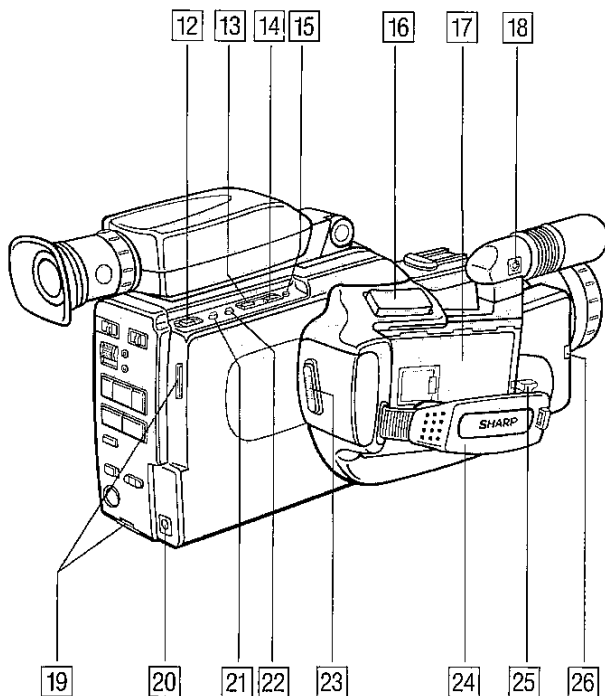

- 12 Sub REC START/STOP button**
Press to start recording. Recording will be paused if pressed during the recording mode. Use when recording from a low angle.
- 13 TRACKING ◀ control button [22] DATE/TIME SET button [7]**
- 14 TRACKING ▶ control button [22] DATE/TIME SELECT button [7]**
- 15 DATE/TIME INITIAL button [7]**
- 16 Power Zoom Wide/Telephoto control button**
Maximum telephoto with T (Tele) depressed (this is also called "zoom-in" or "zoom-up"). Maximum wide angle with W (Wide) depressed (this is also called "zoom-out" or "zoom-down"). You can vary the speed of the zoom from 6 seconds to 20 seconds by the degree of finger pressure on the Zoom buttons.
- 17 Battery Pack Compartment**
- 18 External microphone jack**
- 19 Eyelet tabs**
Pull the shoulder strap through these eyelet tabs and adjust the length of the strap with the buckle.
- 20 DC input jack**
- 21 COUNTER/COUNTER MEMORY/LAP TIME button**
Used to select among Counter, Counter Memory, and Lap Time modes being indicated in the viewfinder.
- 22 COUNTER/LAP TIME RESET button**
Used to reset the Counter and Lap Time being indicated in the viewfinder.
- 23 REC START/STOP button**
Press to start recording. Recording will be paused if pressed during the recording mode.
- 24 Grip Strap**
- 25 Battery release lever**
Used to detach the battery pack.
- 26 SELF TIMER button/Talent Tally indicator**
The Talent Tally indicator will light up when the Camcorder begins recording, enabling the subject to determine whether the unit is recording or not. The SELF-TIMER button and Talent Tally indicator share the same function. When the button is pressed in the REC Pause mode, the indicator will blink for 10 seconds before the Self-timer starts recording.

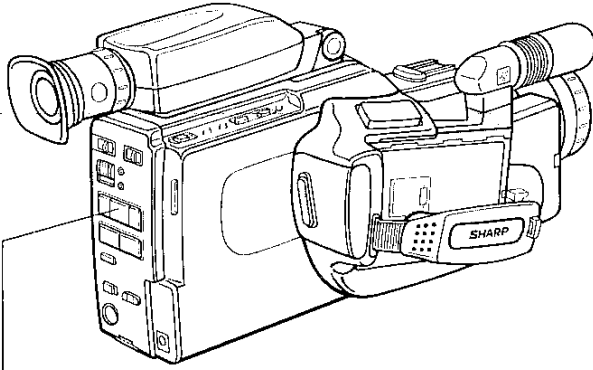

CONTROL PANEL

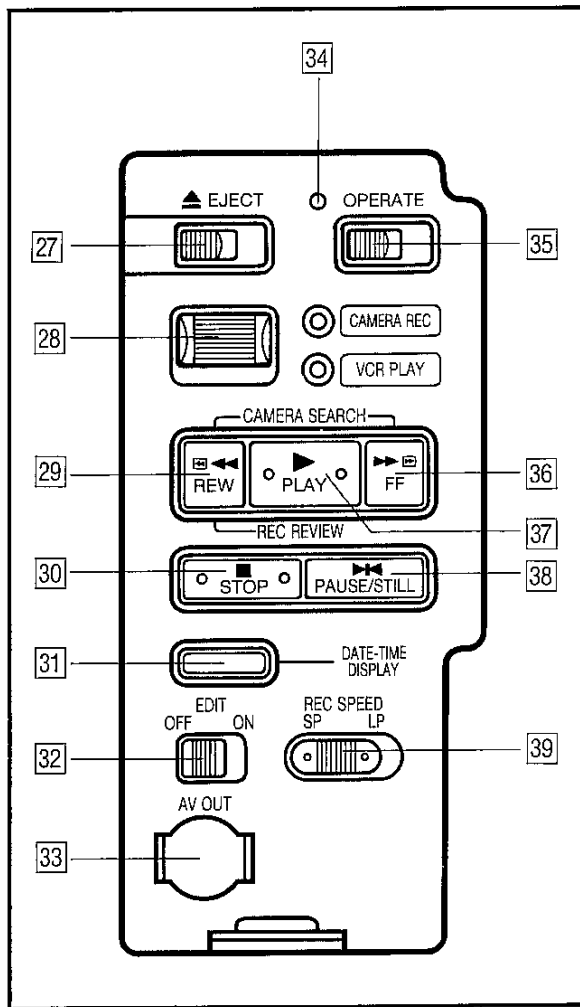

- 27 EJECT button**
Used to insert or remove the **VHS** cassette.
- 28 CAMERA REC/VCR PLAY switch**
When the Camcorder is recording, set this switch to the CAMERA REC position. (The Camcorder will then automatically go into REC PAUSE mode.) When using the Camcorder as a VCR, set this switch to VCR PLAY.
(In this case, if in the REC PAUSE mode, the Camcorder will switch to Still mode; if recording, it will switch to Stop mode.)
- 29 CAMERA SEARCH ◀◀ button [17]**
REW/Reverse Search button [23]
REC REVIEW button [17]
- 30 STOP button**
- 31 DATE-TIME DISPLAY button**
Used to display either the date/time or date in a picture being recorded.
- 32 EDIT switch**
Picture quality inevitably deteriorates each time you dub from the Camcorder to a VCR. Slide the EDIT switch on to minimize deterioration of picture quality. Use this while you edit your videos.
- 33 AV output terminal**
- 34 OPERATE indicator**
- 35 OPERATE on/off switch**
Turns power on and off.
- 36 CAMERA SEARCH ▶▶ button [17]**
FF/Forward Search button [23]
- 37 PLAY button**
Press for playback.
CAMERA SEARCH ▶ button [17]
- 38 PAUSE/STILL button**
Use to view a still picture during playback.
- 39 REC SPEED LP/SP Select switch**
Used to set recording to the LP (Long Play) or SP (Standard Play) mode. Recording time in the respective modes is as follows (VHS-C tape EC-30):
LP mode 60 min.
SP mode 30 min.

PREPARATIONS

INSTALLING THE LITHIUM BATTERY

1 Open the lithium battery compartment cover with a pointed object.

2 Insert the battery with the "+" side out. Close the lithium battery compartment cover.

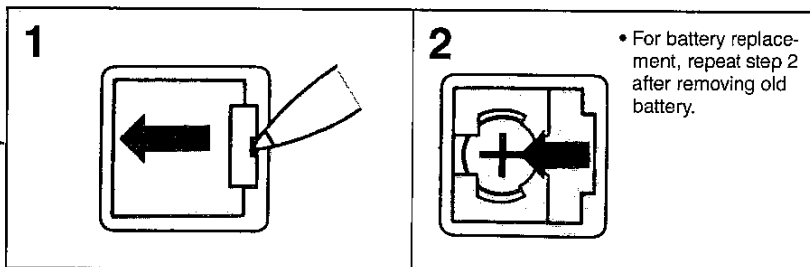
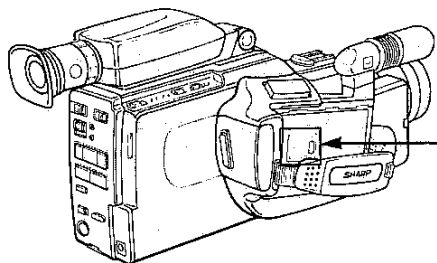

• For battery replacement, repeat step 2 after removing old battery.

Warning:

- Dispose of used battery promptly. Keep away from children. Do not disassemble and do not dispose of in fire.
- The battery used in this device may present a fire or chemical burn hazard if mistreated. Do not recharge, disassemble, heat above 100°C or incinerate. Replace battery with type CR2025 of SHARP ELECTRONICS, SONY ENERGYTEC, FUJI ELECTROCHEMICAL or MATSUSHITA ELECTRIC only. Use of another battery may present a risk of fire or explosion.

Notes

- This lithium battery is available at a local electronic appliance shop or audio/video shop.
- Disconnect the power source (AC adaptor, battery pack, etc.) before replacing the battery.
- The battery life is approximately one year but it differs depending on the ambient temperature and the condition of the lithium battery.
- When the lithium battery runs out, the clock may be extremely inaccurate, or the clock setting mode may be engaged. When this occurs, replace the lithium battery as soon as possible. Reset the date and time after replacing the battery.
- Do not short-circuit the battery by holding the electrodes with metallic objects such as tweezers, as doing so will deteriorate the battery quality.

SETTING THE DATE/TIME

The auto date/time function features a date and time in the viewfinder which can be recorded as a handy reference. Follow the instructions below to set the current date and time.

Example: Setting the date to 25th Oct. 1991 and time to 15:27.

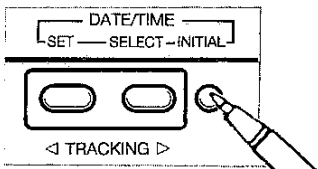
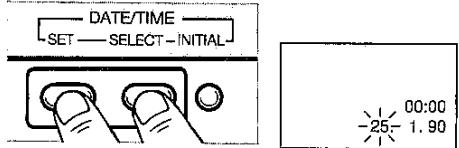
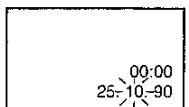
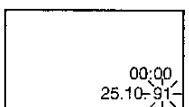
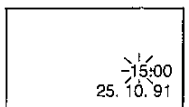
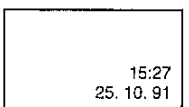
<p>1 Install the date/time lithium battery.</p>	<p>2 Connect a battery pack or power source. Slide the OPERATE switch on. Press the DATE-TIME DISPLAY button.</p>
<p>3 Press the INITIAL button using a dull-pointed object such as a ball point pen.</p> 	<p>4 The day will flash. Press the SELECT button to select the day. When the correct day appears, press the SET button.</p> 
<p>5 The month will flash. Press the SELECT button to select the month. When the correct month appears, press the SET button.</p> 	<p>6 The year will flash. Press the SELECT button to select the year. When the correct year appears, press the SET button.</p> 
<p>7 The hour will flash. Press the SELECT button to select the hour. When the correct hour appears, press the SET button.</p> 	<p>8 The minutes will flash. Press the SELECT button to select the minutes. When the correct time appears, press the SET button.</p> 

ATTACHING AND DETACHING THE BATTERY PACK

Attaching the Battery Pack

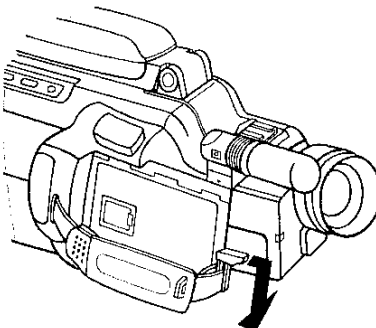
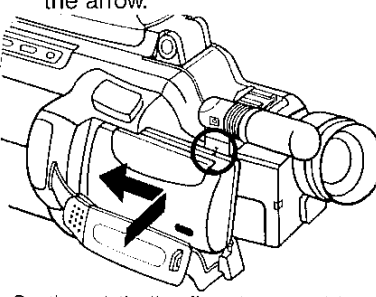
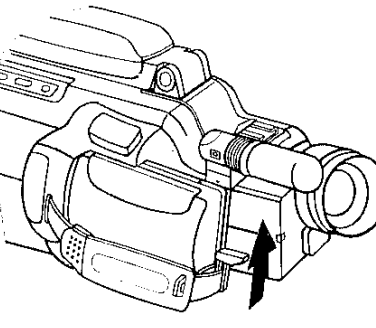
<p>1. Lower the battery release lever by pulling it forward.</p>  <p>A line drawing of a camcorder with the battery pack attached. A black arrow points forward from the battery release lever on the bottom right of the camcorder.</p>	<p>2. Align the "▲" mark on the upper portion of the battery pack with the mark on the camera, and slide it in the direction of the arrow.</p>  <p>A line drawing of the camcorder with the battery pack being inserted. A black arrow points left from the battery pack towards the camcorder. A small triangle mark is visible on the top of the battery pack, and another mark is on the camcorder's body.</p> <p>Gently push the "●" portion toward the Camcorder, and slide left firmly.</p>	<p>3. Raise the battery release lever until it locks into place.</p>  <p>A line drawing of the camcorder with the battery pack fully attached. A black arrow points upward from the battery release lever.</p>
---	--	---

Detaching the Battery Pack

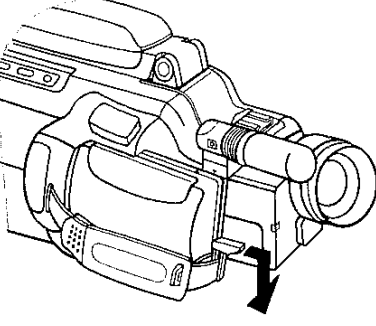
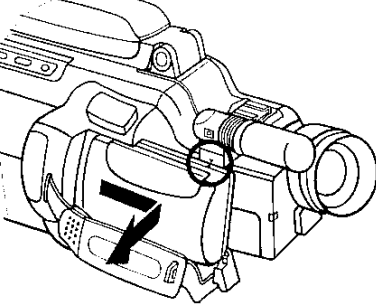
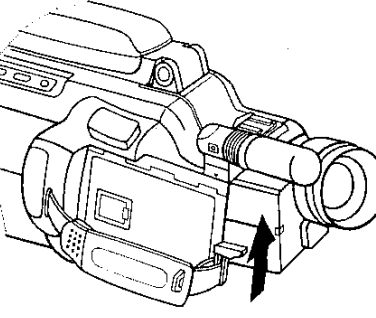
<p>1. Lower the battery release lever by pulling it forward.</p>  <p>A line drawing of the camcorder with the battery pack attached. A black arrow points forward from the battery release lever.</p>	<p>2. Remove the battery pack by sliding it in the direction of the arrow.</p>  <p>A line drawing of the camcorder with the battery pack being removed. A black arrow points right from the battery pack away from the camcorder.</p>	<p>3. Raise the battery release lever until it locks into place.</p>  <p>A line drawing of the camcorder with the battery pack removed. A black arrow points upward from the battery release lever.</p>
---	---	---

Note The battery pack is uncharged when shipped and must be charged before use.

ATTACHING THE SHOULDER STRAP

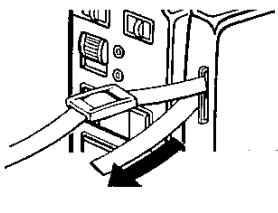
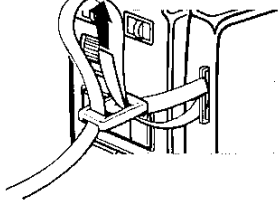
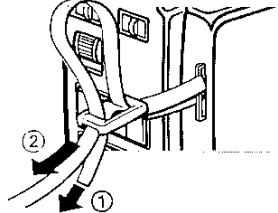
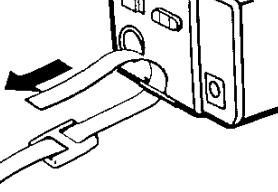
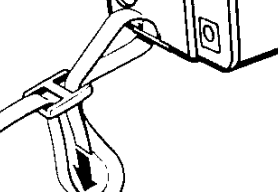
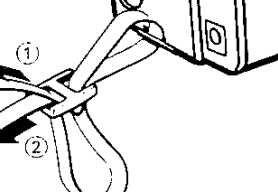
<p>Loop the strap through the eyelet on top of the Camcorder.</p>		
 <p>A line drawing showing the top of the camcorder. A shoulder strap is being looped through an eyelet on the top surface. A black arrow points to the eyelet.</p>	 <p>A line drawing showing the top of the camcorder. The shoulder strap is looped through the eyelet. A black arrow points to the loop.</p>	 <p>A line drawing showing the top of the camcorder. The shoulder strap is looped through the eyelet. A black arrow points to the loop. The number 1 is next to the loop, and the number 2 is next to the strap's end.</p>
<p>Loop the strap through the eyelet at the bottom of the Camcorder.</p>		
 <p>A line drawing showing the bottom of the camcorder. A shoulder strap is being looped through an eyelet on the bottom surface. A black arrow points to the eyelet.</p>	 <p>A line drawing showing the bottom of the camcorder. The shoulder strap is looped through the eyelet. A black arrow points to the loop.</p>	 <p>A line drawing showing the bottom of the camcorder. The shoulder strap is looped through the eyelet. A black arrow points to the loop. The number 1 is next to the loop, and the number 2 is next to the strap's end.</p>

Note Before using the Camcorder, make sure that the shoulder strap is fastened tightly enough, and that no slack exists.

INSERTING AND REMOVING A CASSETTE

Inserting a cassette

- 1 Press the EJECT button to open the cassette compartment. Insert a **VHS** cassette with the transparent window facing you and the arrow facing out. **Remove tape slack before inserting the cassette.**

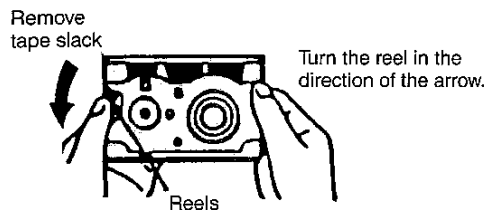

- 2 Press "PUSH" to close the compartment door.

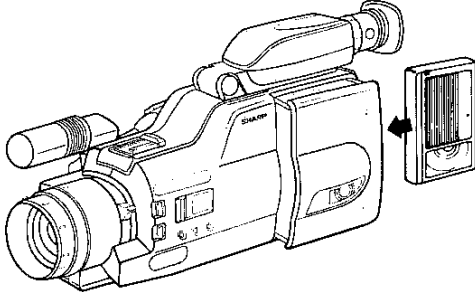

Removing a cassette

- 1 Press the EJECT button. The cassette compartment will open. Remove the cassette.
- 2 Close the compartment door.

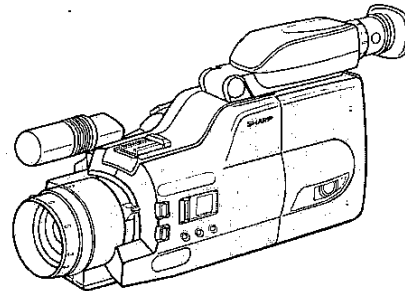

Note

Press on the "PUSH" mark to close slowly and correctly.

Note The cassette may be ejected simply by pressing the EJECT button. There is no need to slide the OPERATE button to off before you press the EJECT button. The cassette cannot be ejected while recording. Go to REC PAUSE mode and press the EJECT button.

ADJUSTING THE GRIP STRAP

Separate the strap to expand the loop, then pass your hand through the loop and grasp the hand grip. Adjust the length of the strap so your hand is secure but comfortable and refasten the strap.

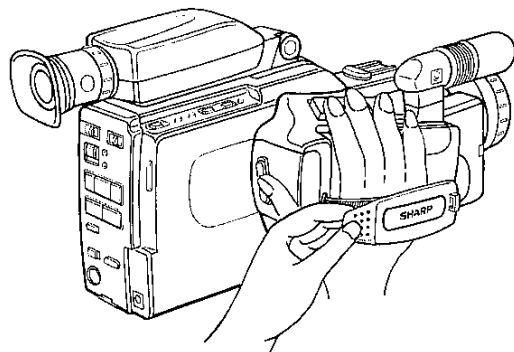

USE OF AN EXTERNAL MICROPHONE

The built-in microphone picks up sounds equally from all directions (omni-directional).

By using an optional VR-67ZM microphone, you can enjoy more effective audio recording.

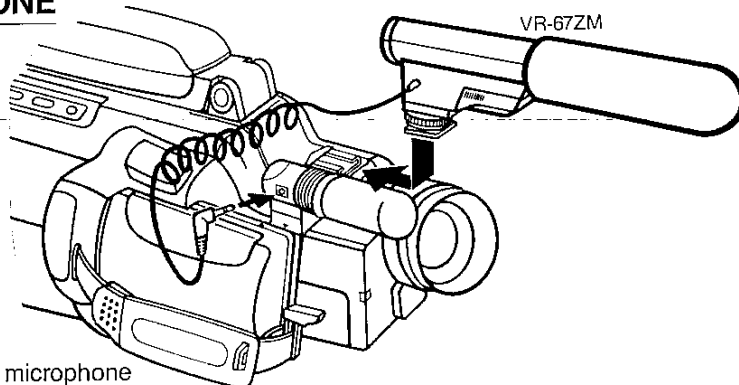

VR-67ZM

Attaches directly to the Camcorder.

This microphone is a highly sensitive 4-times zoom microphone able to collect even distant sounds clearly.

USING THE COLOUR VIEWFINDER

ADJUSTING THE VIEWFINDER POSITION

The viewfinder can be tilted up for low-angle shot.

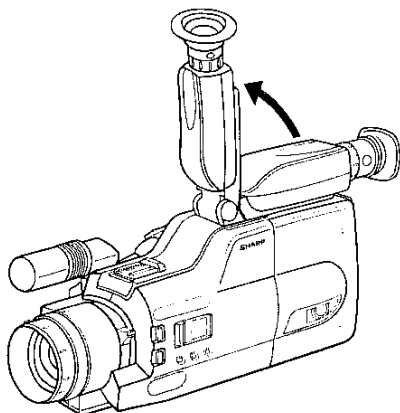

In order to protect the viewfinder while travelling or when the camera is not being used, lay it forward as in the diagram.

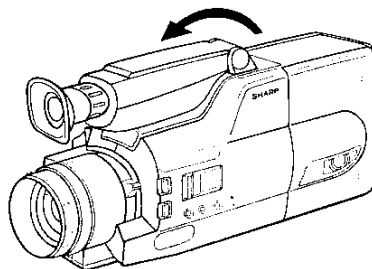

EYEPiece ADJUSTMENT

The Camcorder comes with a diopter adjustment control. Move this control clockwise or counter-clockwise to adjust the eyepiece to your eyesight. As individuals differ in eyesight, adjust the eyepiece so that the characters inside the viewfinder can be seen clearly when used for the first time or by anybody else.

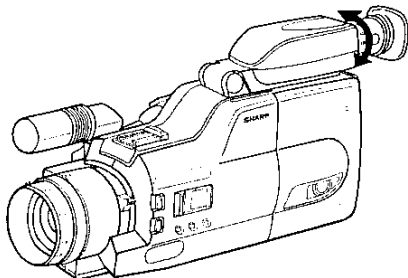

Note Power must be supplied to the Camcorder for this adjustment.

When cleaning dust particles from the interior of the viewfinder, remove the eyepiece, as shown below, and clean with a long, thin object, such as a cotton swab. To remove the eyepiece, first turn it in direction ①, then pull in direction ②. When reattaching, align the marks on the body and the eyepiece as shown, and then turn the eyepiece 45° in direction ③.

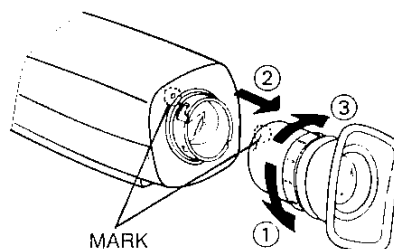

Notes In order to use the viewfinder correctly, please pay attention to the following:

1. On some occasions, even though the operate switch may be on, the colour liquid crystal display may not immediately render a picture.
This does not indicate a defect in your Camcorder. Please wait a moment for the liquid crystal display to normalize.
2. Please do not subject the viewfinder to sharp impact.
3. When recording the same subject for a long period of time, the image may remain on the LCD viewfinder. This is a temporary phenomenon, not a malfunction.

POWER SUPPLY SYSTEM

For portable and outdoor use, the supplied BT-75 battery pack is ideal. Indoors, the supplied AA-75S AC Adaptor/Battery Charger and 2m DC OUT cable will be more useful. For extended outdoor use, the optional VR-P75CH Car Battery Adaptor/Charger may come in handy in remote locations.

Using the AC Adaptor/Battery Charger

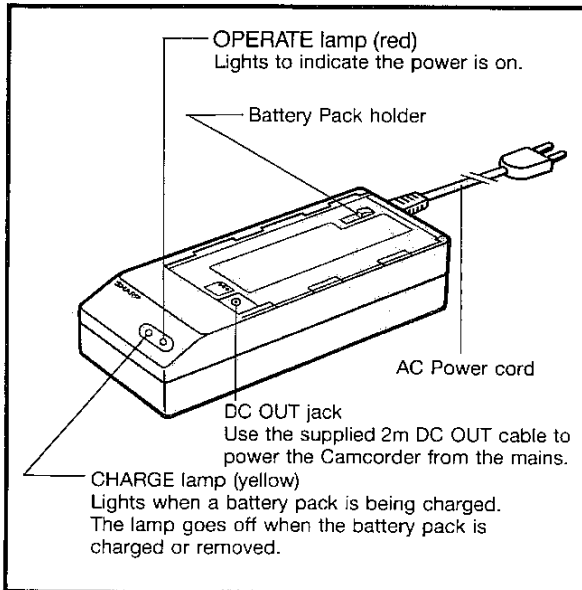

Note

The optional SHARP VR-P75CH Car Battery Adaptor/Charger is like the AA-75S, but operates from a car battery.

Precautions:

- The AC Adaptor/Battery Charger, if used near a radio, may cause interference.
- Prevent flammables, liquids or metal objects from entering the unit.
- The AA-75S is a sealed unit. Do not attempt to open or modify it.
- Do not damage or drop the unit or subject it to vibrations.
- Do not leave the unit in direct sunlight.
- Avoid using the unit in humid or extremely hot places.

USING THE AC ADAPTOR/BATTERY CHARGER

Use the supplied AA-75S AC Adaptor/Battery Charger and DC OUT cable.

- 1** Connect the DC OUT cable to the AC Adaptor and Camcorder.
- 2** Insert the AC plug into a wall outlet. The OPERATE lamp on the AC Adaptor will light.

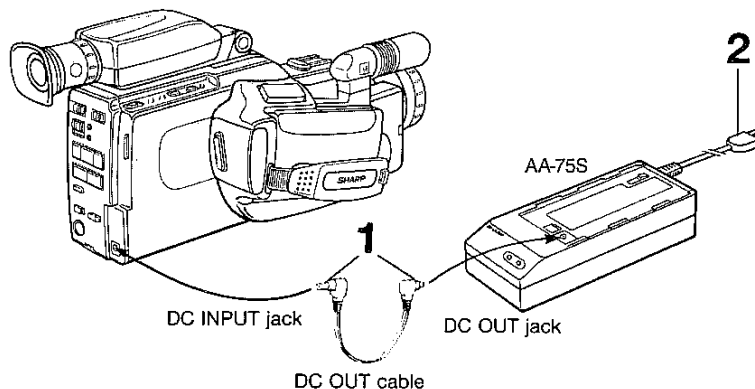

Note The AA-75S AC Adaptor/Battery Charger will not supply power to the Camcorder through the DC OUT cable while charging a battery pack.

CHARGING THE BATTERY PACK

Use the supplied AA-75S AC Adaptor/Battery Charger. Outdoors, you can use the optional SHARP VR-P75CH Car Battery Adaptor/Charger.

- 1 Insert the AC plug in a wall outlet. The OPERATE lamp will light.

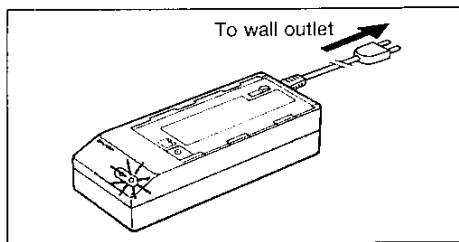

- 2 Align the ▼ mark on the side of the battery pack with the I mark on the charger and guide the battery pack into the groove. Slide the battery pack forward until it locks in place. The CHARGE lamp will light.

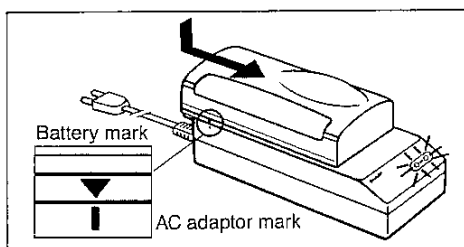

- 3 When the battery pack is charged the CHARGE lamp will go off. Pull out the AC plug from the wall outlet and remove the battery pack by sliding it back.

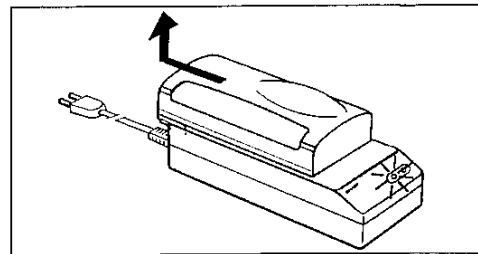

Note

Normally the battery pack and charger are warm after charging.

CHARGING TIME of BT-75: 60 min.
CHARGING TIME of BT-76: 80 min.

Note

The charging time depends on the ambient temperature and the condition of the battery pack.

USING THE CAR BATTERY ADAPTOR/CHARGER (OPTIONAL ACCESSORY)

To charge the battery pack or power the Camcorder in a car, use the optional SHARP VR-P75CH Car Battery Charger.

- 1 Start the car engine and leave it idling while using the Car Battery Charger. Insert the plug into the car cigarette socket. The OPERATE lamp will light.
- 2 Connect the DC OUT cable to supply power to the Camcorder. The CHARGE lamp will be lit while the battery pack is charging. When charging is completed, the CHARGE lamp will go off, and the DONE lamp will light.

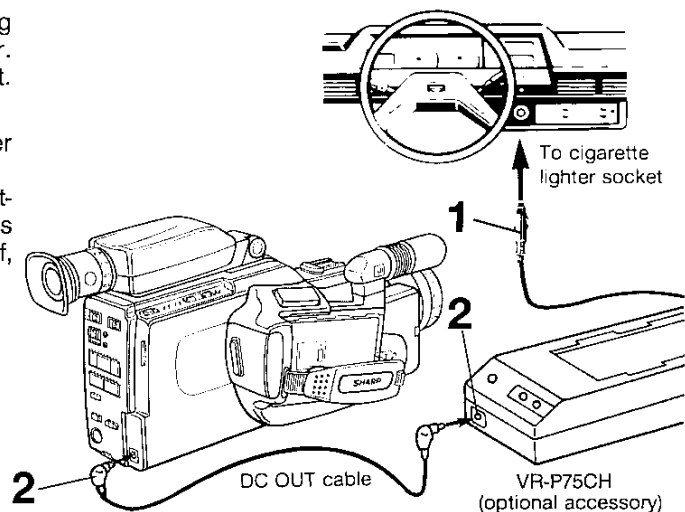

Note

The VR-P75CH Car Battery Adaptor/Charger will not supply power to the Camcorder through the DC OUT cable while charging a battery pack.

Caution:

The VR-P75CH Car Battery Charger can only be used with 12V or 24V negative-ground cars.

Do not use with 12V or 24V positive-ground cars. Check the car operation manual or consult your car dealer.

USING THE BATTERY PACK

The BT-75 is a nickel-cadmium battery and has the following characteristics.

Recharging normally takes one hour at a room temperature of 20°C. The lower the temperature, the longer the recharging time.

Temperature Range

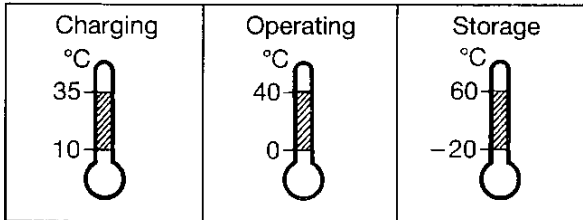

To avoid hazard:

- Do not burn the battery pack.
- Do not short circuit the terminals.
- Do not disassemble or modify it.
- Use only recommended SHARP chargers: AC Adaptor/Battery Charger AA-75S or Car Battery Adaptor/Charger VR-P75CH.

To prevent damage and prolong battery life:

- Do not damage or drop the unit or subject it to mechanical vibration.
- Avoid repeated charging without discharge of the battery pack.

The battery pack has a limited life; when it begins to deliver less recording time per charge, purchase a replacement.

Note

The battery pack is normally warm after charging or use.

RECORDING TIME of BT-75: approx. 60min.
RECORDING TIME of BT-76: approx. 80min.

The recording time of a fully charged battery pack is influenced by the amount of recording and standby time, use of the zoom lens and other factors.

Spare battery packs are available from your SHARP dealer. Have spare battery packs on hand, otherwise you may miss important video opportunities.

Nickel-cadmium batteries are best when maintained under the following conditions:

1. Full charging takes place between 10°C and 35°C. Charging takes longer at lower temperatures and charging may be incomplete at higher temperatures.
2. Store battery packs in a cool dry place. Long exposure to high temperatures increases battery discharge and reduces battery life.
3. Total battery discharge may naturally occur during long storage. Discharge batteries before storing them — this extends battery life.
4. Detach batteries from Camcorder or charger after use, otherwise battery discharge may continue.

CAMERA RECORDING

CAMERA RECORDING

- 1 Attach the recharged battery pack. (See page 8.) However, use the supplied AC adaptor for indoor camera recording or an optional Sharp car battery adaptor/charger for recording in a car.

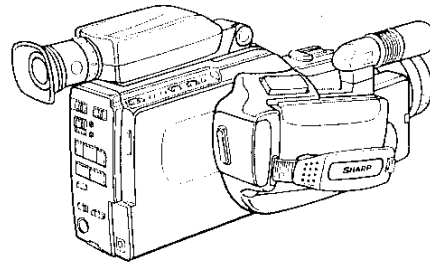

- 2 Slide the OPERATE switch on — the operate indicator will light. Press the EJECT button and open the cassette holder. Insert a VHS video cassette with its tab intact and with its window facing outward. Press on the "PUSH" mark to close the compartment door.

Caution:

Before inserting the video cassette, be sure to check that the tape is not slack. If there is tape slack, turn the reel in the direction of the arrow.

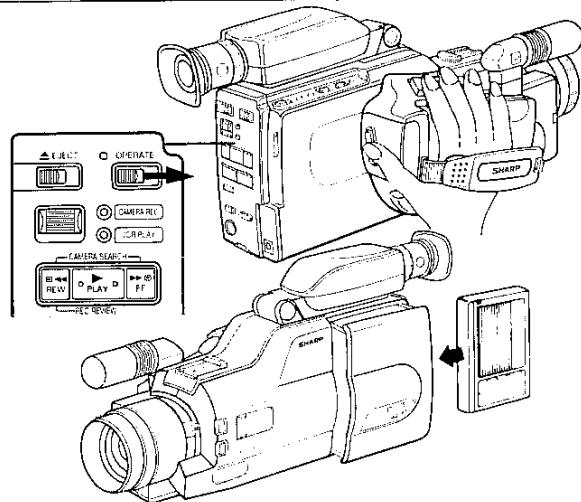
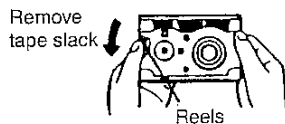

- 3 Position your hand properly to allow your fingers to press the REC START/STOP button and Power Zoom button. Then adjust the grip strap to suit your hand.

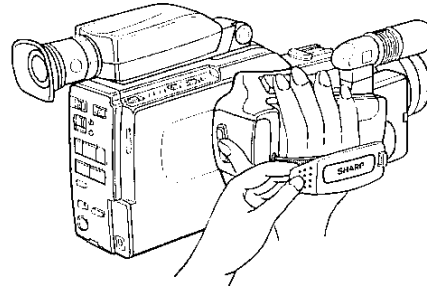

- 4 Remove the lens cap and secure it to the grip band. Then aim the camera at a solid colour subject (the sky or a white wall) and adjust the diopter adjustment so the display in the viewfinder becomes clear.

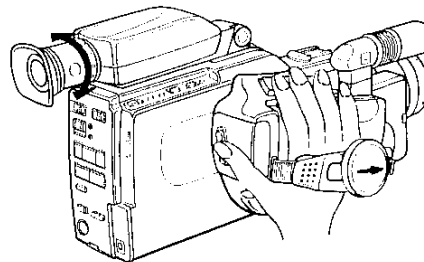

- 5** Press the REC Speed LP/SP select switch and set the recording time. This causes the selected recording mode to appear in the viewfinder. Recording time on the **VHS** tape EC-30 is as follows.

SP mode: 30 minutes
LP mode: 60 minutes

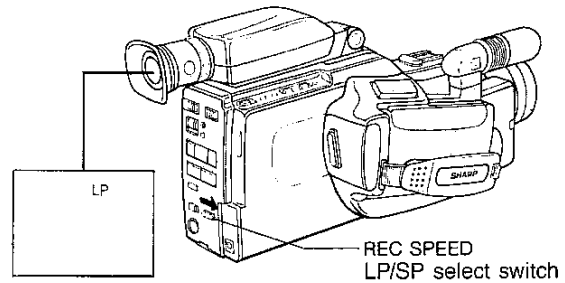

- 6** Set the CAMERA REC/VCR PLAY switch to "CAMERA REC" position.

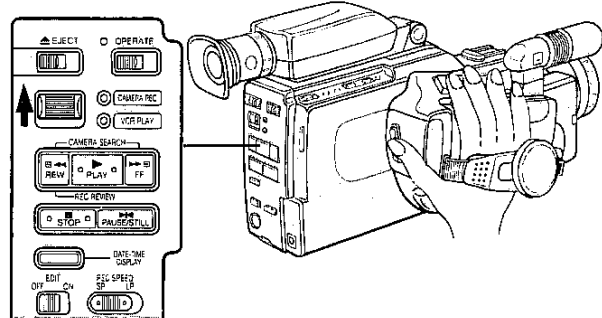

- 7** Set the FULL AUTO switch to "FULL AUTO" position. Make certain that the "▶▶▶▶" and "⊗" marks appear in the LCD display. If the "▶▶▶▶" and "⊗" marks are flashing, an alarm indicator will appear in the viewfinder. (See page 19.)

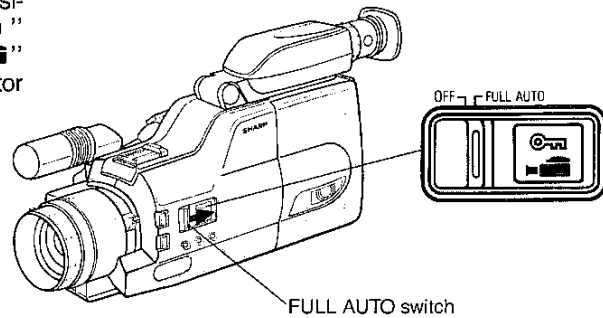

- 8** Press the REC START/STOP button. While recording, "▶▶▶▶" in the viewfinder moves in sequence from left to right.

Note

If recording for an extended period of time, the handgrip may become hot. However, this does not indicate malfunction.

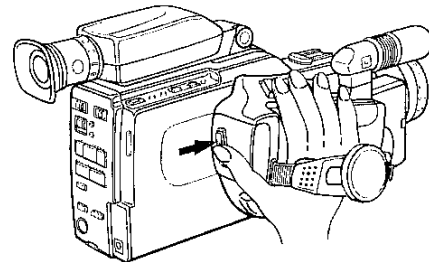

- 9** When you wish to finish recording, press the REC START/STOP button once again.

Note

If the Camcorder is in the REC PAUSE mode for more than 5 minutes, it will switch itself off. To restart recording just slide the OPERATE switch to ON.

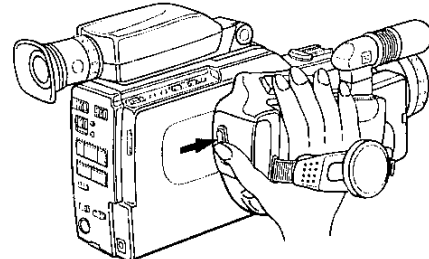

FULL AUTO SYSTEM

Setting the FULL AUTO switch to "FULL AUTO" position sets the Focus and White Balance to the AUTO modes and the shutter speed to STANDARD mode. This makes it possible for anyone to make accurate Camcorder recordings. When the FULL AUTO switch is set to the "FULL AUTO" position, the FULL AUTO mark "⏻" and "📷" mark normally appear on the LCD display. However, if the "⏻" and "📷" mark start flashing, other alarm indicators may appear in the viewfinder. These indicators mean that camera recording is not possible for some reason, such as if a cassette with its tab removed has been loaded into the Camcorder.

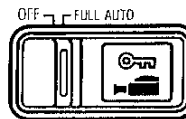
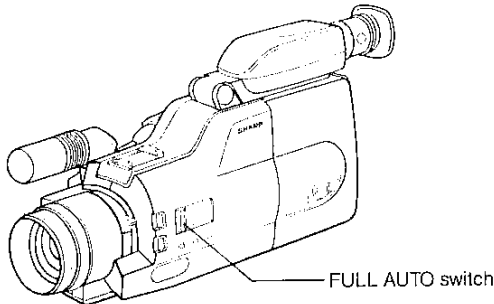

Camera recording is possible in the FULL AUTO mode when the ⏻ mark and 📷 mark appear.



When any alarm indicator appears in the viewfinder follow the alarm immediately. (See page 19.)

AUTO FOCUS

Autofocus lets you concentrate on creating great videos, knowing they will be perfectly focused.

In the FULL AUTO position, the focus is continuously adjusted to maintain the best focus. There is a small area in the centre of the viewfinder which detects the subject distance and sets the focus. Try and keep the subject in the middle of the viewfinder.

Note

The autofocus may not be able to focus on a subject in the following situations. Manually focus the lens to obtain the correct focus.

Cautions:

- Do not touch the focus ring while the autofocus mechanism is operating.
- If the lens is dirty or obscured, accurate focusing may be difficult. Keep these clean at all times. If they become dirty, clean with a soft tissue and use lens cleaning fluid to clean the lens. Should condensation occur, dry by wiping with a soft cloth or wait until the condensation evaporates.
- When recording subjects that change rapidly, such as when zooming rapidly from wide-angle to telephoto, panning quickly from a distant scene to one nearby, etc., it sometimes takes a few seconds before the subject is in focus.

 Subject too dark.	 Lack of contrast, ie. snow scene.	 Scene includes objects at uniform distance apart.	 Light reflects off the subject.
 Two subjects at different distances overlap in the same scene.	 Subject extends from foreground into background.	 Fast-moving subject.	 Background is too bright.
 Subject has fine, repeated patterns.	 Subjects at different distances appear in the center of the viewfinder at the same time.	 Subject has horizontal stripes.	 Subject is skewed.
 Subject is being shot through a dirty or wet window.	 High-speed electronic shutter being used under fluorescent lighting.	Note We recommend that you start recording after focusing on a subject.	

AUTO WHITE BALANCE

Your Camcorder is equipped with automatic white balance which ensures good colour in your videos. Correct colour balance is important for accurate colour reproduction.

The white balance is automatically adjusted to compensate for any changes in the colour temperature of the light.

REC REVIEW

While recording, press the REC START/STOP button to REC PAUSE ("-----" will light in the viewfinder), and very briefly press the REC REVIEW button.

About the last 2 seconds of the recording are rewound and played back. The Camcorder is then ready to continue recording. If you hold down the REC REVIEW button, the CAMERA SEARCH function will be engaged.

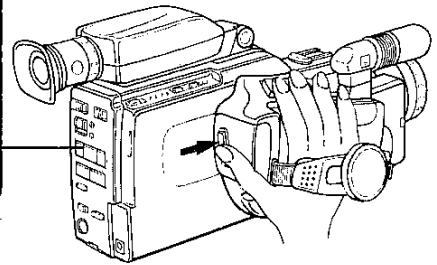
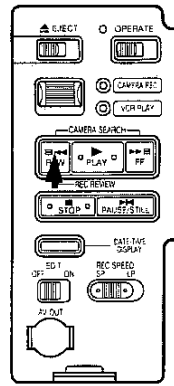

CAMERA SEARCH

If, while recording, you have mistakenly recorded something you don't want, you can search for the location of the unnecessary portion while still in the CAMERA REC position.

- 1** Press the REC START/STOP button to pause the recording.
- 2** While looking into the viewfinder, continue pressing the CAMERA SEARCH button to search for the location you wish to record over. The recorded picture appears in the viewfinder.
- 3** When the portion you wish to record over appears, release the CAMERA SEARCH button. (The REC PAUSE mode will resume after a 1 second long still frame has appeared.)
- 4** Press the REC START/STOP button to record over the unwanted section.

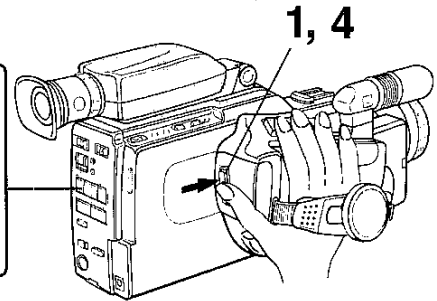

AN EXPLANATION OF BUTTON OPERATIONS

If you hold down the "▶▶▶" button, images can be replayed in order at 3 times regular speed. (There will be no sound.)

If you hold down the "▶" button, images can be replayed in order at regular speed. (With sound)

If you hold down the "◀◀◀" button, images can be replayed in reverse order at 3 times regular speed. (There will be no sound.)

POWER ZOOM (WIDE/TELEPHOTO CONTROL)

One of the best features of this Camcorder is the variable speed power zoom.

Press the power zoom buttons to zoom in and out on a subject. The pressure of your finger tips controls the zoom speed.

The zooming speed is controlled by your finger pressure, so the harder you press, the faster the zoom speed.

Press the power zoom buttons firmly to rapidly zoom in or out in 6 seconds, or press the power zoom buttons lightly to slowly zoom in or out in 20 seconds.

T(ele) brings things closer to you, while W(ide) makes things appear further away.

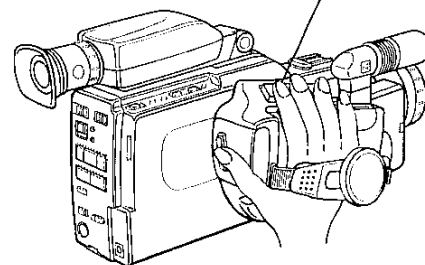
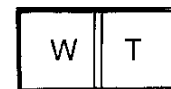

LAP TIME FUNCTION

This Camcorder has a LAP TIME function which counts the approximate recording time.

- 1** Slide the OPERATE switch to on.
- 2** Slide the CAMERA REC/VCR PLAY switch to "CAMERA REC". The Camcorder will automatically switch to the REC PAUSE mode.
- 3** Press the COUNTER/COUNTER MEMORY/LAP TIME button and select LAP TIME.
- 4** Press the RESET button. (LAP TIME will reset to "0:00".)
- 5** Slide the REC SPEED LP/SP select switch to set the recording speed. Set the FULL AUTO switch to "FULL AUTO" position.
- 6** Press the REC START/STOP button (LAP TIME starts).
- 7** To stop recording, press the REC START/STOP button again (LAP TIME stops).

Notes

- With the Lap Time mode you can know the approximate time of the recording. The counter's maximum time is "99:99" (99 min. 99 sec.).
- The LAP TIME counter counts only during recording. (The LAP TIME mode is activated even if there is no display in the viewfinder.)
- When the tape is ejected, the LAP TIME counter is automatically reset to "0:00".
- Even if you press the COUNTER/COUNTER MEMORY/LAP TIME button during playback, the LAP TIME will not be displayed. (In this case only the COUNTER will be displayed.)

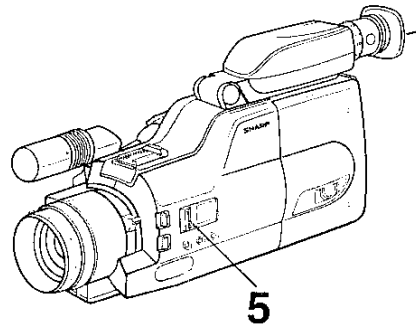
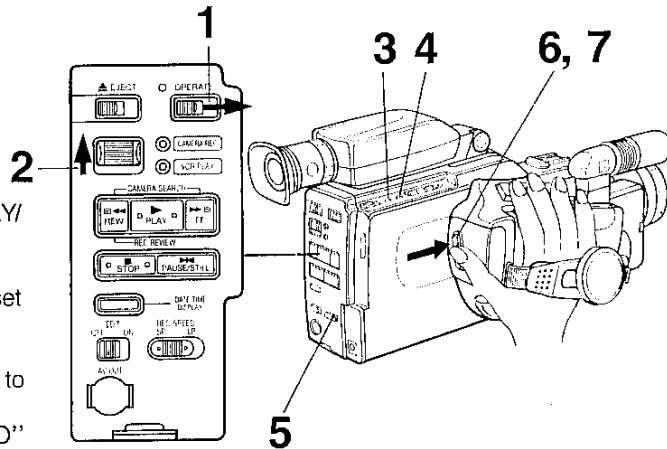

Viewfinder indicator

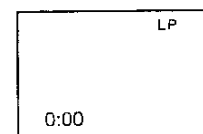

Start



Stop

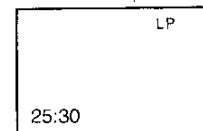

LCD DISPLAY AND VIEWFINDER INFORMATION

The Camcorder provides information needed for camera recording on the LCD display and in the viewfinder.

ALARM INDICATORS

	<p>1) DEW Condensation on tape drum. The power will cut off in a few minutes. Wait several hours before resuming use. (See page 2.) (At this time, the OPERATE indicator also blinks.)</p>		<p>4) Video cassette alarm Recording cannot be carried out because the video cassette has its tab removed or no video cassette is loaded. Load a video cassette with its tab intact.</p>
	<p>2) Battery and alarm The battery is too low. The power will be cut off in a few seconds. Replace the battery pack.</p>		<p>5) Tape-end alarm The tape will come to its end in about 3 minutes. Prepare a new video cassette with an intact tab.</p>
	<p>3) LIGHT There is not enough light to make a good recording. Add supplementary lighting or move to a brighter location.</p>		<p>The tape has come to its end. Replace it with a new one with an intact tab.</p>
			<p>6) Heads need cleaning The heads need cleaning. Call for service.</p>

Note When the above indicators appear, the FULL AUTO mark  and the  mark blink simultaneously.

CONVENIENCE INDICATORS

	<p>1) FULL AUTO indicator The FULL AUTO indicator appears when the FULL AUTO switch is set to "FULL AUTO" position. This makes the Camcorder capable of proper camera recording.</p>		<p>4) Date/Time This unit is equipped with an AUTO DATE/TIME function. The DATE/TIME display button is pressed to set the display to either the date/time or date. The set display can be recorded on the tape along with the picture.</p>										
	<p>2) Recording indicator When the REC START/STOP button is pressed and recording begins, ">>>>" appears, moving in sequence from left to right.</p>												
	<p>When the REC START/STOP button is pressed again, the Camcorder changes to REC PAUSE, and "-----" will appear.</p>		<p>5) Tape counter Continues to function even when the indicator is not shown in the viewfinder. The numbers in the tape counter continue to change as the tape travels. If the Counter memory is engaged, "M" appears to the left of the tape counter indicator.</p>										
<p>Note This indicator appears only when the CAMERA REC/VCR PLAY switch is in the "CAMERA REC" position.</p>			<p>6) Lap time counter The lap time is displayed in minutes and seconds during recording. (See page 18.)</p>										
	<p>3) Recording mode Recording at the speed shown. "SP": Recording at the standard play speed. "LP": Recording at the long-play speed.</p>		<p>7) High Speed Shutter Recording When the SHUTTER SPEED button is pressed, the shutter speed changes as follows.</p> <table border="0"> <tbody> <tr> <td>1/100</td> <td>: 1/100 sec.</td> </tr> <tr> <td>1/500</td> <td>: 1/500 sec.</td> </tr> <tr> <td>1/2000</td> <td>: 1/2000 sec.</td> </tr> <tr> <td>1/10000</td> <td>: 1/10000 sec.</td> </tr> <tr> <td>No display</td> <td>: Standard mode (1/50 sec.)</td> </tr> </tbody> </table>	1/100	: 1/100 sec.	1/500	: 1/500 sec.	1/2000	: 1/2000 sec.	1/10000	: 1/10000 sec.	No display	: Standard mode (1/50 sec.)
1/100	: 1/100 sec.												
1/500	: 1/500 sec.												
1/2000	: 1/2000 sec.												
1/10000	: 1/10000 sec.												
No display	: Standard mode (1/50 sec.)												

CONVENIENCE INDICATORS

M/F	8) Manual Focus The manual focus mode is engaged. "M/F" appears when the AUTO/MANUAL FOCUS button is pressed.	* LIGHT *	10) Gain-up The gain-up mode is engaged. "* LIGHT *" appears when the BLC/GAIN-UP button is pressed while "LIGHT" is displayed.
W/B	9) White Balance Lock The white balance lock mode is engaged. "W/B" appears when the WHITE BALANCE button is pressed.	FADER	11) FADE The fade stand-by mode is engaged. When the REC START/STOP button is pressed, Fade in or Fade out is obtained.

Note If you use a TV as a monitor, only the date or date/time appear in the viewfinder.

AUTO DATE/TIME FUNCTION

The auto date/time function features a date and time which can be recorded as a handy reference. Follow the procedures outlined below for recording the date or date/time along with the subject.

Note

If the date and time are not set, the DATE-TIME DISPLAY button will not function. (See page 7.)

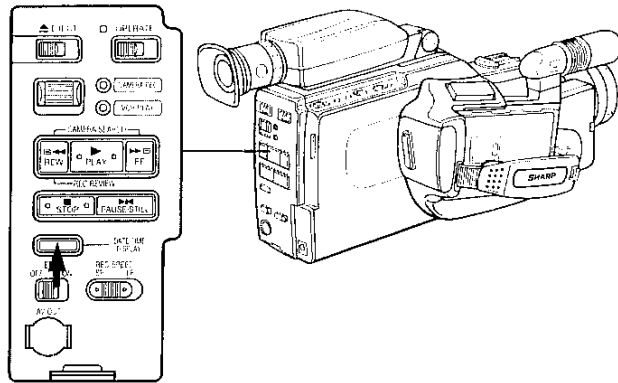

- 1 Connect to a power source and slide the OPERATE switch to on. Slide the CAMERA REC/VCR PLAY switch to "CAMERA REC" and the Camcorder will change to REC PAUSE.
- 2 Press the DATE-TIME DISPLAY button. Either the date or date/time will be displayed in the viewfinder. Pressing this button changes the display in the viewfinder as follows, and either the date or date/time can be set.

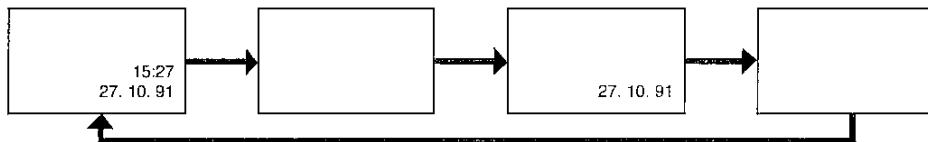

- 3 Press the REC START/STOP button. The date or date/time displayed in the viewfinder will be recorded along with the subject.

ASSEMBLE RECORDING

To record on a partially recorded tape or produce an assembly recording:

- 1** Slide the EJECT button and insert a cassette with its tab in place.
- 2** Slide the CAMERA REC/VCR PLAY switch to "VCR PLAY".
- 3** Press the PLAY button and use the FF or REW button to quickly locate the exact point, then press the PAUSE/STILL button.
- 4** Slide the CAMERA REC/VCR PLAY switch from "VCR PLAY" to "CAMERA REC".
- 5** Press the REC START/STOP button.

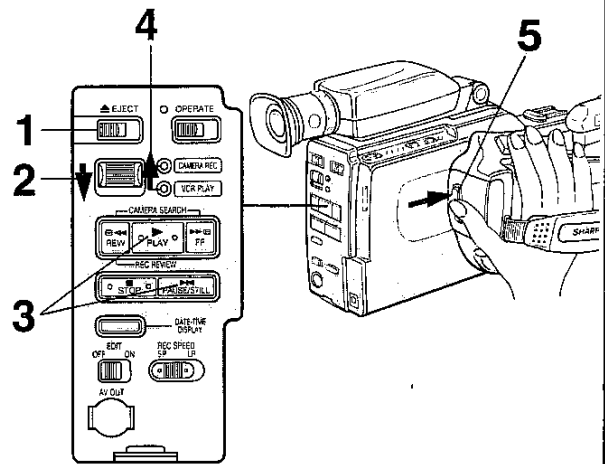

REPLACING THE BATTERY PACK WHILE RECORDING

1. If BATTERY is blinking in the viewfinder while recording, press the REC START/STOP button to stop recording, then slide the OPERATE switch off.
2. Replace the battery pack with a charged one.
3. Slide the OPERATE switch on. "-----" will be displayed in the viewfinder.
4. Press the REC START/STOP button to continue recording from the same place as before.

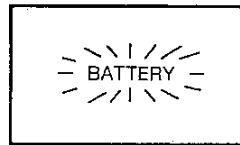

Note

Make sure the power is off — the OPERATE indicator should be off — before removing the battery pack.

AUTO POWER OFF

To protect the tape and conserve battery power, the Camcorder releases the tape tension and switches itself off when in REC PAUSE mode ("-----" displayed in viewfinder) for more than 5 minutes.

Power Supply	CAMERA REC/VCR PLAY position	Operation About 5 min.
Battery/AC	CAMERA REC	REC PAUSE → POWER off

PLAYBACK

The VL-C7200S can playback VHS-C cassettes you have recorded. They can be played back on the viewfinder or a TV.

PLAYBACK IN THE VIEWFINDER

- 1** Attach a Battery Pack or use the AC Adaptor/ Battery Charger.
 - 2** Slide the OPERATE switch on — the OPERATE indicator will light.
 - 3** Slide the CAMERA REC/VCR PLAY switch to the "VCR PLAY" position.
 - 4** Press the EJECT button and insert a video cassette.
- Note**
Remove any tape slack first.
- 5** Cue the tape to the scene you want to watch by pressing the FF or the REW button. Then press the PLAY button and playback starts.

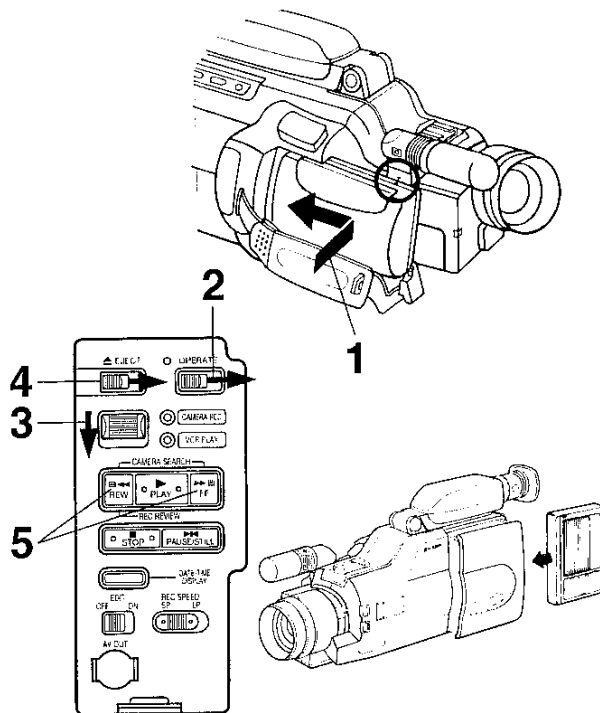

Notes

- When the tape reaches the end, the Camcorder will rewind the tape automatically.

Note

The LP/SP select switch may be in either mode. The recording speed is automatically sensed and the tape is played back at the correct speed.

TRACKING ADJUSTMENT

If noise bars are visible or if the picture is noisy, adjust the TRACKING control. Press either of the TRACKING buttons to reduce the picture noise. After playback, press both of the TRACKING buttons at the same time to return the tracking to the centre position.



Visual "Noise"

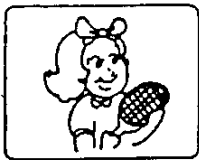

Clear

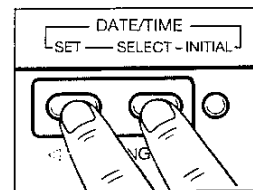

TRACKING control

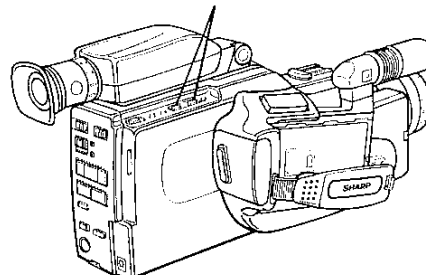

FORWARD/REVERSE SEARCH AND STILL

To quickly locate a point on a recorded tape, use the Forward and Reverse Search buttons.

Forward Search

Press the FF(▶▶) button during playback. This speeds playback up to 3 times faster than normal for an SP recorded tape and 7 times faster for an LP recorded tape.

Reverse Search

Press the REW(◀◀) button during playback. This speeds up reverse playback to 3 times faster than normal for an SP recorded tape and 7 times faster for an LP recorded tape.

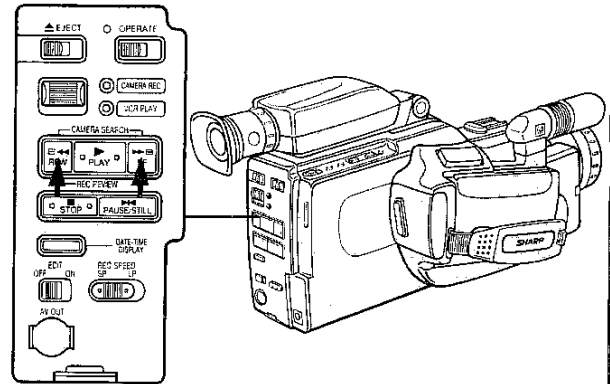

Note There may be some picture noise during Forward/Reverse Search. This is normal. If the TV picture rolls vertically, adjust the TV vertical hold control. The picture may go monochrome during Forward/Reverse Search on a recorded tape. This is normal. Audio will not be heard.

Still

Press the PAUSE/STILL button during playback to still the picture. To resume playback, press the PAUSE/STILL button again.

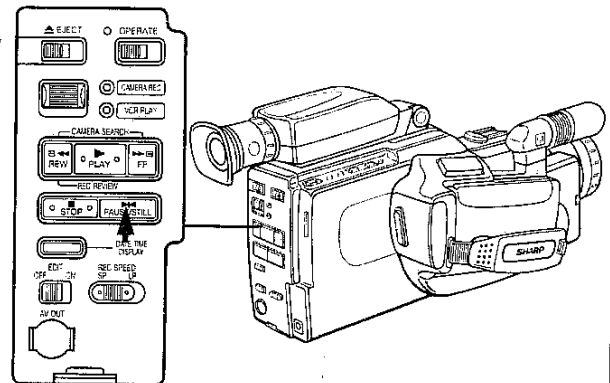

Note

If the TV picture rolls vertically, adjust the TV vertical hold control.

To protect the tape, the Camcorder releases the tape tension and resumes STOP mode when left longer than 5 minutes in STILL mode during playback.

About 5 min.

STILL → STOP

COUNTER MEMORY FEATURE

The 4-digit display acts as a handy reference to help you locate specific scenes. Use the tape counter memory to quickly return to a favourite scene.

— When the memory is on, the tape stops when the counter reads "M0000" during FF and REW.

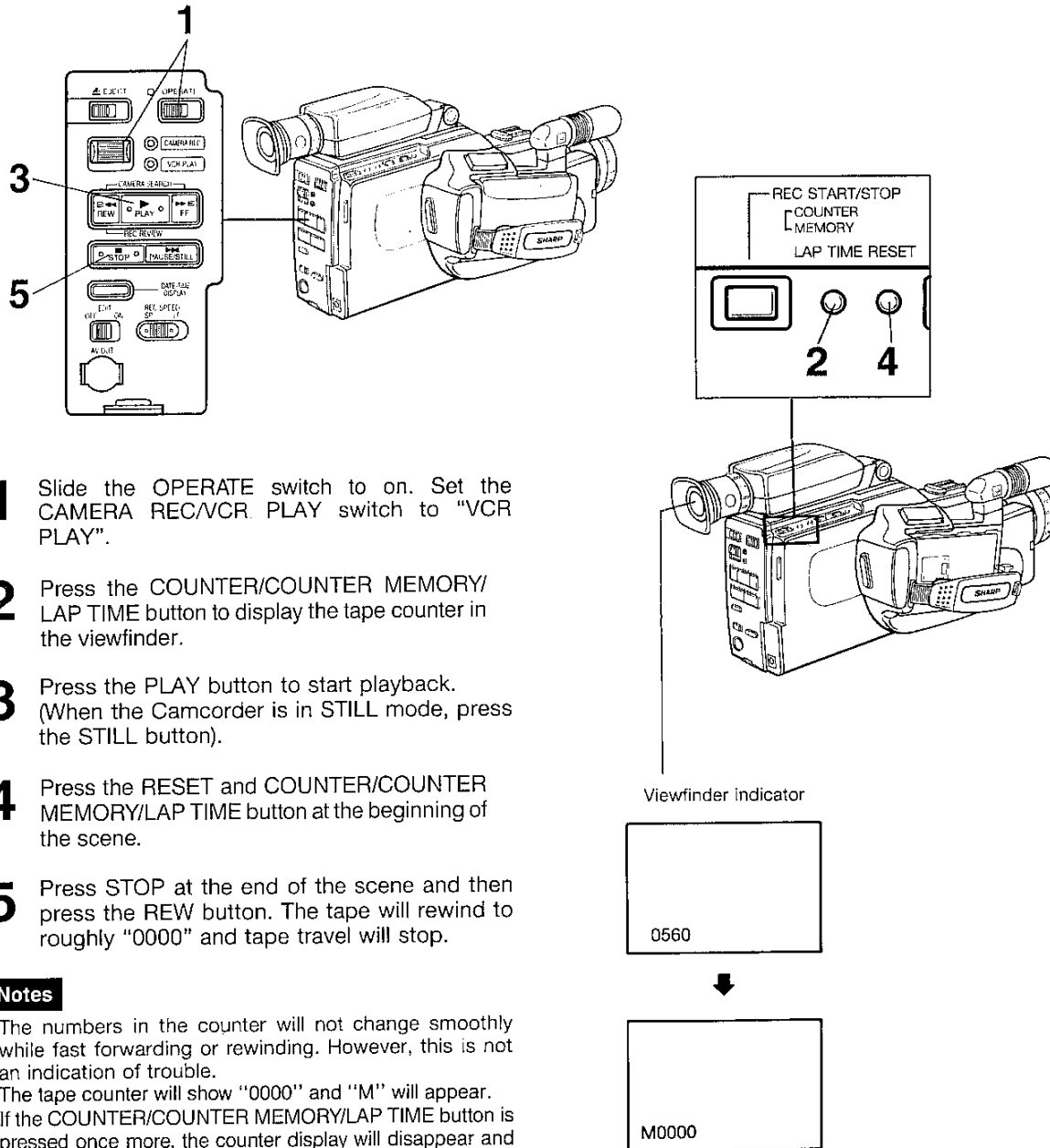

- 1** Slide the OPERATE switch to on. Set the CAMERA REC/VCR PLAY switch to "VCR PLAY".
- 2** Press the COUNTER/COUNTER MEMORY/LAP TIME button to display the tape counter in the viewfinder.
- 3** Press the PLAY button to start playback. (When the Camcorder is in STILL mode, press the STILL button).
- 4** Press the RESET and COUNTER/COUNTER MEMORY/LAP TIME button at the beginning of the scene.
- 5** Press STOP at the end of the scene and then press the REW button. The tape will rewind to roughly "0000" and tape travel will stop.

Notes

- The numbers in the counter will not change smoothly while fast forwarding or rewinding. However, this is not an indication of trouble.
- The tape counter will show "0000" and "M" will appear.
- If the COUNTER/COUNTER MEMORY/LAP TIME button is pressed once more, the counter display will disappear and the memory feature will not function. (During the CAMERA REC mode, it is also possible to switch on the LAP TIME counter by pressing the COUNTER/COUNTER MEMORY/LAP TIME button.)
- Tape travel will also stop at roughly "0000" when the tape is fast forwarded.
- Counter memory feature works only when the CAMERA REC/VCR PLAY switch is in the "VCR PLAY" position.

CONNECTION TO TV

To playback tapes recorded with your Camcorder on your TV, connect the optional RF Converter between your TV and the Camcorder.

Connection to normal TV.

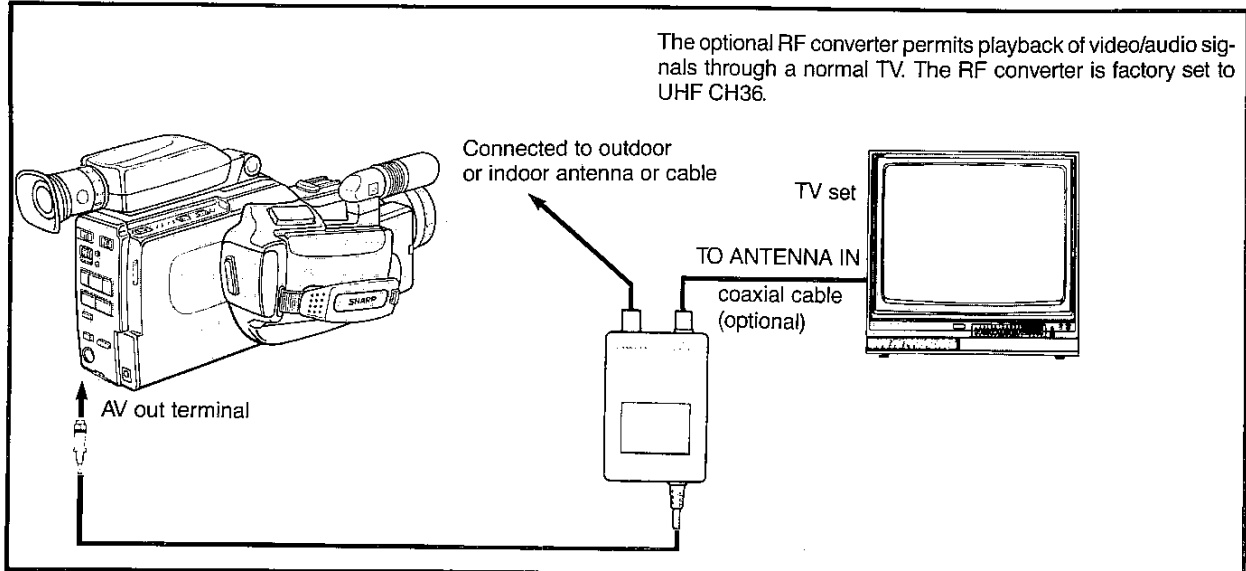

TV PLAYBACK

Tune the TV to the same channel as the RF converter (UHF CH30 ~ 39) and press the PLAY button.

To resume normal TV operation, slide the OPERATE switch off on the Camcorder or unplug the RF Converter cable from the Camcorder.

- 1 The channel adjuster on the optional RF converter is set to CH36. If CH36 is used in your area, set it to a different channel (see Note).

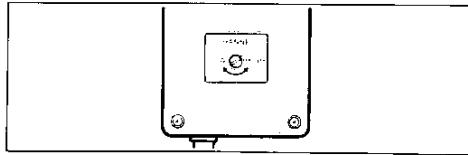

- 2 Set the TV tuner to the same channel.
- 3 Unplug the antenna cable from the TV and plug it into the ANTENNA IN terminal on the RF converter.
- 4 Plug the optional 75-ohm coaxial cable into the RF OUT terminal on the RF converter and the 75-ohm coaxial antenna terminal on the TV.
- 5 Plug the RF converter cable into the AV out terminal on the Camcorder.
- 6 Slide the CAMERA REC/VCR PLAY switch to the "VCR PLAY" position and slide the OPERATE switch on.
- 7 Press the EJECT button and insert a video cassette, with the cassette window facing outward. Press the PLAY button.

Precautions

- Use the optional RF converter only with the Camcorder.
- The RF converter is a sealed unit. Do not attempt to open or modify it. Do not damage or drop the unit or subject it to mechanical vibration.
- Unplug the RF converter during lightning storms.

OPERATION

Viewing a video cassette being played back with the VL-C7200S.

To view video cassettes or to monitor the recording, set the TV channel selector to the channel corresponding to the RF output channel.

Viewing television programmes:

Slide the OPERATE switch to off or unplug the RF converter cable from the Camcorder.

Note

If UHF channel 36 is an active broadcast channel in your area, any nonbroadcast channel from UHF channels 30 to 39 can be selected for viewing the Camcorder's output on TV. Adjust the RF Converter Output Channel adjuster to any of those channels (UHF30-39), and tune your TV to the same one.

CONNECTION TO TV WITH A/V TERMINALS

- 1** Plug the supplied A/V OUTPUT cable with 21-pin Euro-SCART into the AV OUT terminal on the Camcorder.
- 2** Plug the 21-pin A/V OUTPUT cable connector into the A/V terminal (21-pin Euro-SCART) on the TV.
- 3** Tune the TV to the VIDEO or A/V channel.
- 4** Slide the OPERATE switch to on.
Slide the CAMERA REC/VCR PLAY switch to the "VCR PLAY" position.
- 5** Press the EJECT button and insert a video cassette. Press the PLAY button.

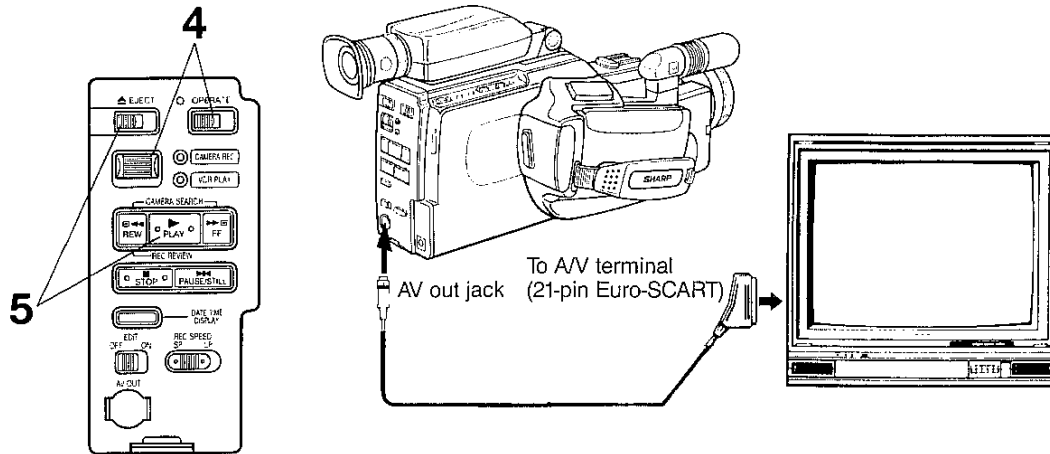

TV Playback

Tune the TV to the VIDEO or A/V channel and press the PLAY button.

To resume normal TV operation, tune the TV to another channel.

RECORDING TO ANOTHER VCR

Your SHARP Camcorder can be connected as the playback source deck for dubbing and editing a tape with another VCR. Unnecessary scenes can be removed, the overall length shortened, scenes moved and rearranged, and other effects added to make your tapes more effective and enjoyable.

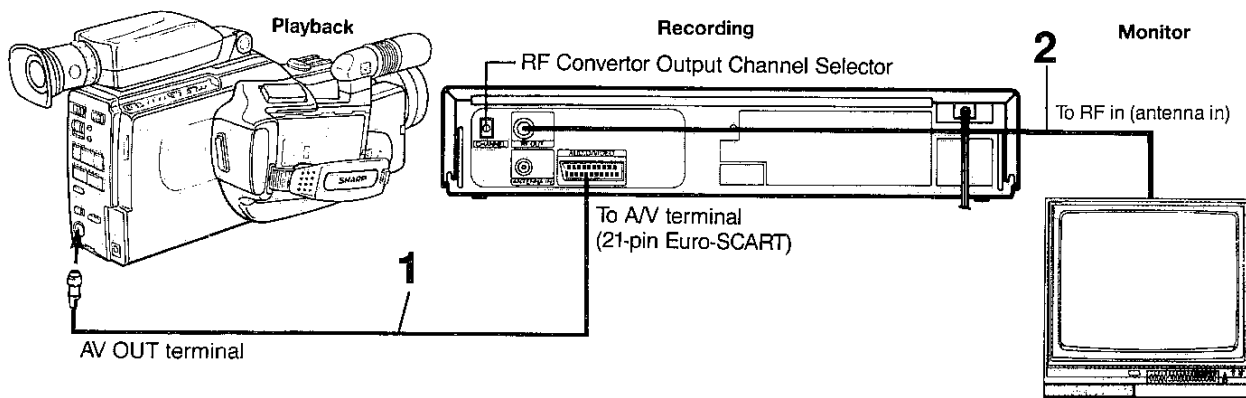

- 1** Plug the AV OUTPUT cable into the AV OUT terminal on the rear of the Camcorder. Plug the 21-pin AV OUTPUT connector into the AV terminal on the rear of the VCR.
- 2** Monitor recording on a TV connected to the VCR.
- 3** Connect a power source to the Camcorder and slide the OPERATE switch to ON. Now turn on the VCR too.
- 4** Slide the Camcorder CAMERA REC/VCR PLAY switch to "VCR PLAY" and insert a recorded tape.
- 5** Insert a cassette tape with erasure protection tab intact into the VCR and put it into REC PAUSE mode.
- 6** Locate the scene to be copied from your Camcorder and press the PAUSE/STILL button.
- 7** Slide the EDIT switch to ON.
- 8** Press the PAUSE/STILL button on your Camcorder and on the VCR to begin playback and dubbing.

Note

Picture quality inevitably deteriorates with each copy. The standard tape speed (SP) mode is therefore recommended when dubbing a tape.

EDIT CONTROL

Picture quality inevitably deteriorates each time you dub from the Camcorder to a VCR. Slide the EDIT switch on to minimize deterioration of picture quality. Use this while you edit your videos.

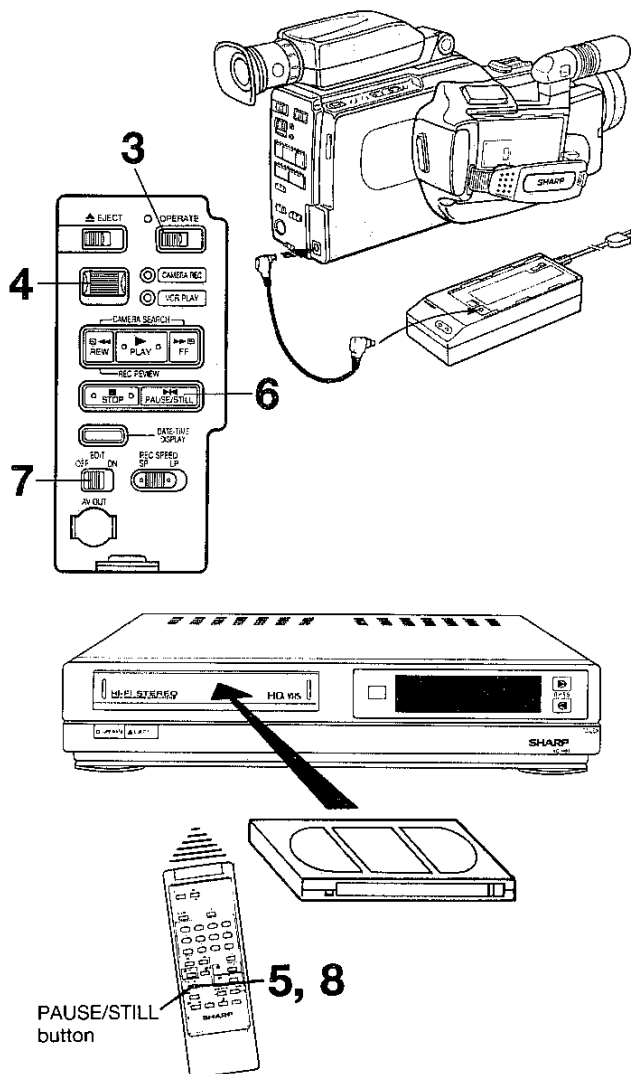

Note

- Normally, the EDIT switch should be off.

USING THE CASSETTE ADAPTOR (OPTIONAL ACCESSORY)

The VHS compact video cassettes recorded with the VL-C7200S can be played back with a standard VHS machine by using the optional VR-72CA Cassette Adaptor.

(A compact video cassette installed in the cassette adaptor is fully compatible with a standard VHS machine for both recording and playback.)

Inserting the Battery into the Cassette Adaptor
The VR-72CA Cassette Adaptor is battery operated by one Type R6 (AA) battery

Remove the battery cover by sliding it up.
Install one Type R6 (AA) battery and reattach the cover.

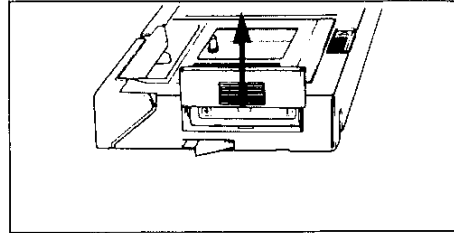

Inserting a Compact Video Cassette into the Cassette Adaptor.

If there is slack in the video tape when inserting the compact cassette into the adaptor, the tape may become damaged. Take up slack in the tape.

- 1** Push the sliding latch in the direction of the arrow to open the door.

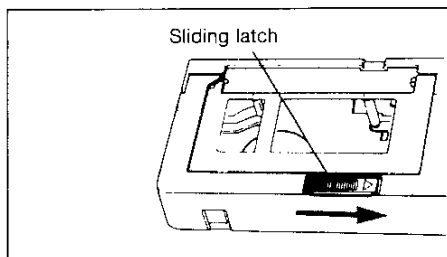

- The compartment door opens.

- 2** Insert the cassette as illustrated.

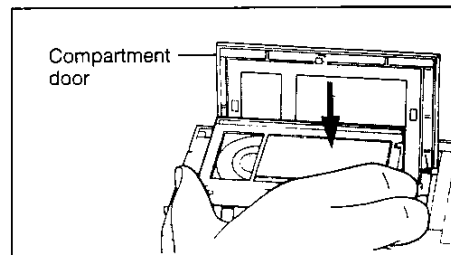

- Be sure to insert it squarely, not tilted.
- Be sure there is no slack in the tape.
- Do not touch the tape when inserting a compact cassette into the cassette adaptor.

- 3** Close the compartment door.

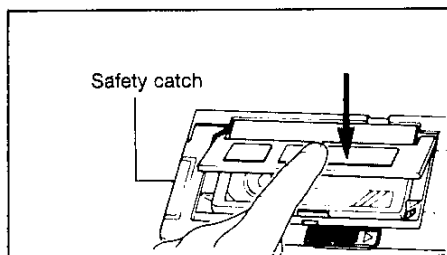

- The tape will be threaded automatically.

- 4** The safety catch will retract. This indicates that the tape threading is completed.

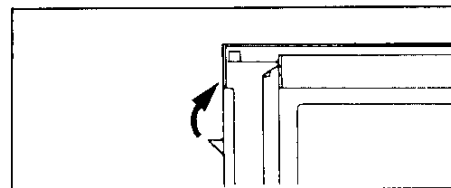

Caution:

During tape loading and unloading, do not touch the cassette's reels for safety and tape protection.

Caution:

Check the tape condition after inserting the cassette and tape loading is completed:

1. Check to see if there is any tape slack.
(Do not open the tape cover.)
2. If there is tape slack, remove it by turning the reel in the direction of the arrow.

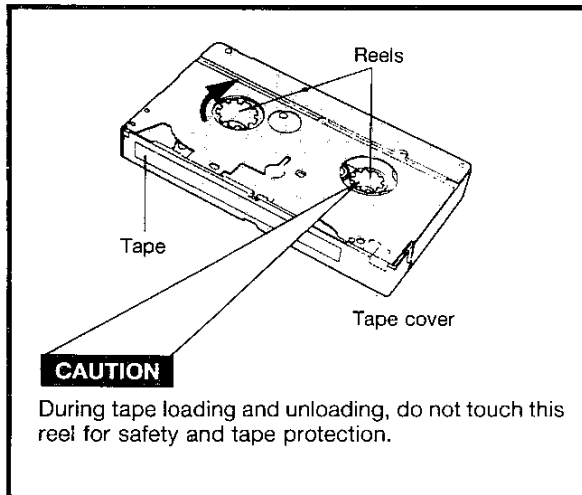
**Playing Back the Tape**

1. Load the cassette adaptor into a VHS deck in the same way as you would load a regular VHS tape.
2. Operate the VHS deck as usual.
 - Note that playback special effects can be performed using the VHS deck.
 - If noise bars appear, adjust the tracking of the playback deck. Be sure to reset the tracking control to its normal position when you have finished playing back compact VHS tapes.
 - Consult the VCR's operation manual for operation instructions.

Notes

- During special effects playback (slow motion, still frame, etc.) the picture may vibrate or noise bars may appear on the screen.
- The protruding safety catch indicates that loading of the tape has not been completed. In this condition, NEVER attempt to load the cassette adaptor into a VCR, as this could damage both.
- Do not load and unload the cassette adaptor into a VCR repeatedly without allowing the tape to run. This will slacken the tape and thereby damage it.
- The cassette adaptor cannot be loaded upside down.
- After use, remove the cassette from the adaptor.

Removing the Compact Video Cassette

Slide the latch to open the door, then push up on the cassette to remove it, pushing on the cassette with your finger through the hole in the bottom of the adaptor.

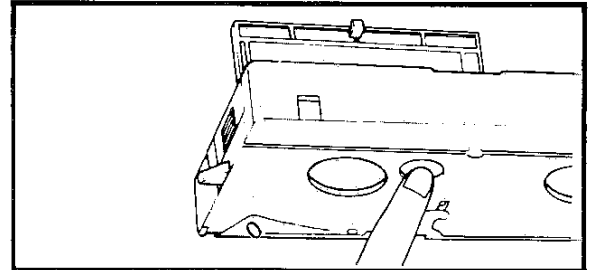
**Notes**

- This cassette adaptor is precision-manufactured. Avoid violent vibrations or shocks. Do not drop or disassemble or modify it, otherwise malfunctions may result.
- When placing the cassette adaptor into its case, slide the cassette adaptor into the case, safety catch end first.

Video Cassettes

- The VL-C7200S employs only compact video cassettes carrying the **VHS** mark.
- Recording onto prerecorded tapes automatically erases the previously recorded video and audio signals.
- An inverted cassette cannot be inserted.
- Do not load and unload the cassette repeatedly without allowing the tape to run at all. This will slacken the tape and thereby damage it.
- Make certain before loading the cassette that the tape is not slackened. If there is any slack, turn the gear on the cassette in the direction of the arrow to take up slack.
- The cassette is equipped with a safety tab to prevent accidental erasure. When the tab is removed, recording is impossible. If you wish to record on a cassette whose tab has been removed, use adhesive tape to reseal the slot.
- To avoid excessive exposure to dust and fingerprints, do not open the front tape cover.

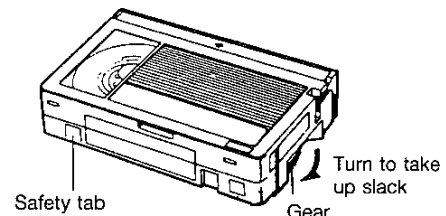
**Storage of Cassettes**

- Avoid exposing the cassettes to direct sunlight. Keep them away from heaters.
- Avoid storing the cassettes in humid or dusty places.
- Do not drop the cassettes. Do not expose them to violent vibrations or shocks.
- Do not expose the cassettes to strong magnetic fields (near a motor, transformer or magnet).
- Place the cassettes in cassette cases and position them vertically.

ADVANCED OPERATION

MANUAL FOCUS

In the following cases, it may be difficult to use the Autofocus, so you might want to focus the lens yourself.

1. When the object is not in the middle of the scene.
2. When you want the background or the front of the scene blurred.
3. When you want to have the beginning of the scene out-of-focus.

USING THE MANUAL FOCUS

- 1 Turn off the FULL AUTO switch.
- 2 Press T to zoom in on your subject.
- 3 Press the FOCUS button to select MANUAL FOCUS.
- 4 Turn the focus ring until the subject is focused.
- 5 Lightly press W and zoom out to compose the scene.

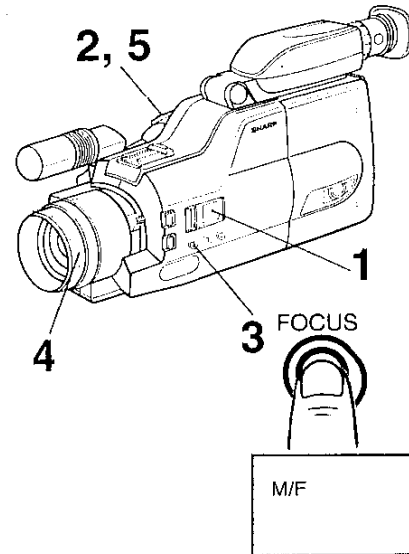

In the manual focus mode, "M/F" is displayed in the viewfinder.

WHITE BALANCE

White balance ensures that all the colours in a scene are correctly reproduced. In the auto mode, white balance is adjusted automatically.

Using the White Balance Lock mode

Colour shift may occur when a solid coloured object is recorded, so that the viewfinder is filled with one colour, eg., when a close up of solid coloured paper is taken. The Auto White Balance mode is locked into place to avoid a colour shift in such situations. Follow the procedure described below to lock the Auto White Balance mode.

(1) When Quick Action is required.

Zoom out all the way on a subject that is not one solid colour. Under this condition, the proper white balance will be set automatically.

Press the WHITE BALANCE button to lock the white balance setting. "WB" appears in the viewfinder. Colour shift can be avoided when the white balance is locked even when recording a close up of a solid coloured subject.

(2) When a very accurate white balance setting is required.

Focus on a white piece of paper so that the viewfinder is filled with it and keep focusing for about 2 seconds. Then the proper white balance will be set automatically. Turn off the FULL AUTO switch, and press the WHITE BALANCE button to lock the white balance setting. "WB" appears in the viewfinder.

To disengage the White Balance Lock mode, press the WHITE BALANCE button, or slide the FULL AUTO switch to FULL AUTO mode to return to the Auto White Balance mode. The colour temperature of a light source varies. For instance, the colour temperature of sunlight will vary depending on the weather and time of day. Reset the White Balance Lock if the colour temperature changes.

Notes

- If power to the Camcorder is interrupted during White Balance Lock, if or the Camcorder is switched to the VCR mode, White Balance Lock will be cancelled.
- Even though the White Balance Lock mode is on, the White Balance is not perfectly locked. Therefore the White Balance compensation function can adjust to small variations in colour temperature, giving your recordings more natural colour.

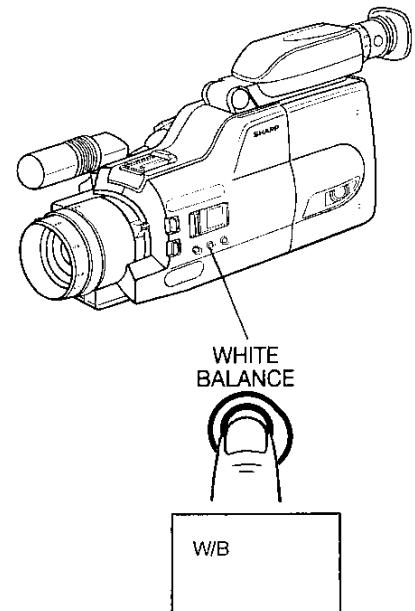

In the White Balance Lock mode, "WB" is displayed in the upper left of the viewfinder. (If the White Balance Lock mode is disengaged, the display disappears.)

Under the following conditions Auto White Balance may not function correctly.

- When mixing natural and artificial light. Beware of window scenes containing a mixture of artificial and natural light. Likewise all lighting should have the same colour temperature.
- When using special effects lighting.
- When recording a subject against a background with an intense hue.
- When there is insufficient light.
- When the colour temperature of a scene changes too rapidly or there is too much contrast.
- When the object is a solid colour.

BACKLIGHT COMPENSATION

The Auto Iris in this Camcorder uses a new light measuring system to automatically control bleaching and adjust to backlit subjects. However, if the background is too bright and the subject appears dark, press the BLC/GAIN-UP button to prevent the subject from appearing dark on the recording.

Note

The Camcorder will automatically return to the AUTO IRIS mode after you release the BLC/GAIN-UP button.

GAIN-UP

"LIGHT" is displayed in the viewfinder when recording a dark subject. If the BLC/GAIN-UP button is pressed, the scene becomes brighter.

"* LIGHT *" is displayed in the viewfinder to indicate that the gain-up mode is engaged.

When the subject becomes brighter, "* LIGHT *" disappears.

However, memory of the gain-up mode remains.

In order to disengage the gain-up mode completely, press the BLC/GAIN-UP button while "* LIGHT *" is displayed in the viewfinder.

Note

- In the gain-up mode, there will be more picture noise.
- If power is interrupted or the Camcorder is switched to the playback mode, the Gain-up mode will be cancelled.

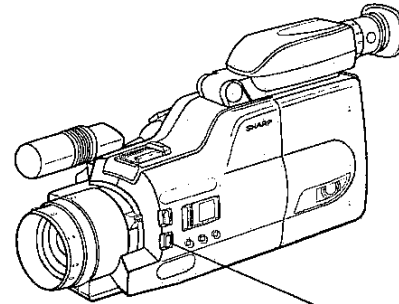

BLC/GAIN-UP

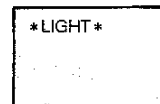

If the gain-up mode is engaged, "* LIGHT *" is displayed in the viewfinder.

SELF TIMER RECORDING

- 1 Attach the battery pack.
- 2 Press the EJECT button and open the cassette holder. Insert a video cassette with its tab intact with its window facing outward. Press the corner of the cassette holder marked "PUSH" until it clicks into place.
- 3 Mount this Camcorder on a stable tripod designed for video use, then slide the OPERATE switch on.
- 4 Set the CAMERA REC/VCR PLAY switch to the "CAMERA REC" position.
- 5 Set the FULL AUTO switch to the "FULL AUTO" position, and check that and are displayed in the LCD.
- 6 Pointing the Camcorder at the subject, press the Power Zoom button and adjust the angle of view.
- 7 Press the SELF TIMER button. The talent tally indicator flashes for 10 seconds, then the Camcorder will record for 20 seconds, then change to REC PAUSE mode. If you wish to record for an extended time, press the SELF TIMER button twice in succession.

Note

If you press the SELF TIMER button three times, the SELF TIMER is cancelled.

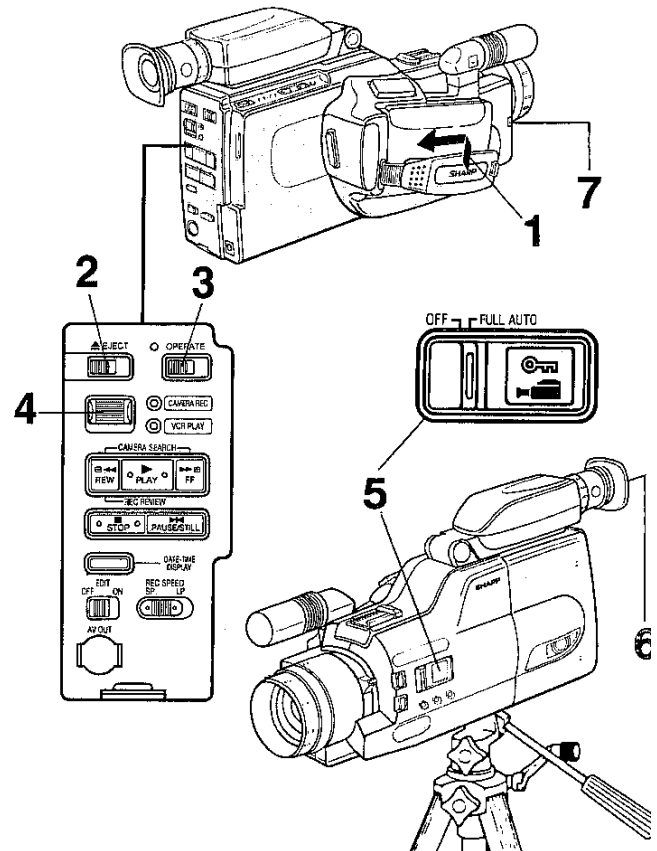

HIGH SPEED SHUTTER

Use the HIGH SPEED SHUTTER (1/10,000, 1/2,000, 1/500, 1/100 sec.) mode when recording fast moving objects like sports (tennis, golf, etc.). When you playback the scene on a 4-head VCR, the playback picture will be clear even in the STILL and SLOW modes.

USING THE HIGH SPEED SHUTTER

1 While in the REC PAUSE mode, turn off the FULL AUTO switch, and press the SHUTTER SPEED select button. Select the shutter speed desired. Shutter speeds change in the following order: 1/10,000 sec., 1/2,000 sec., 1/500 sec., 1/100 sec., standard (1/50 sec.), and back to 1/10,000 sec.

2 Press the REC START/STOP button to start recording as normal. Since the High Speed Shutter is faster than normal, it requires more light. Use the High Speed Shutter in appropriate light (minimum required lighting is listed below.)

1/10,000 sec.:	3,000 lux
1/2,000 sec.:	600 lux
1/500 sec.:	150 lux
1/100 sec.:	30 lux

It is recommended to use the High Speed Shutter outdoors or with extra light.

Notes

- Avoid using High Speed Shutter under fluorescent lighting as this will cause flickering in the picture.
- Recording with shutter speeds higher than 1/50 sec. (standard) tends to darken the picture. Record in bright locations when using other shutter speeds.

PLAYBACK OF SCENES RECORDED WITH THE HIGH SPEED SHUTTER MODE

1 Place the recorded tape into the optional [VHS] cassette adaptor and then into a [VHS] 4-head video cassette recorder.

2 When watching scenes taken with the HIGH SPEED SHUTTER you can enjoy blur-free recordings even during STILL and SLOW mode playback.

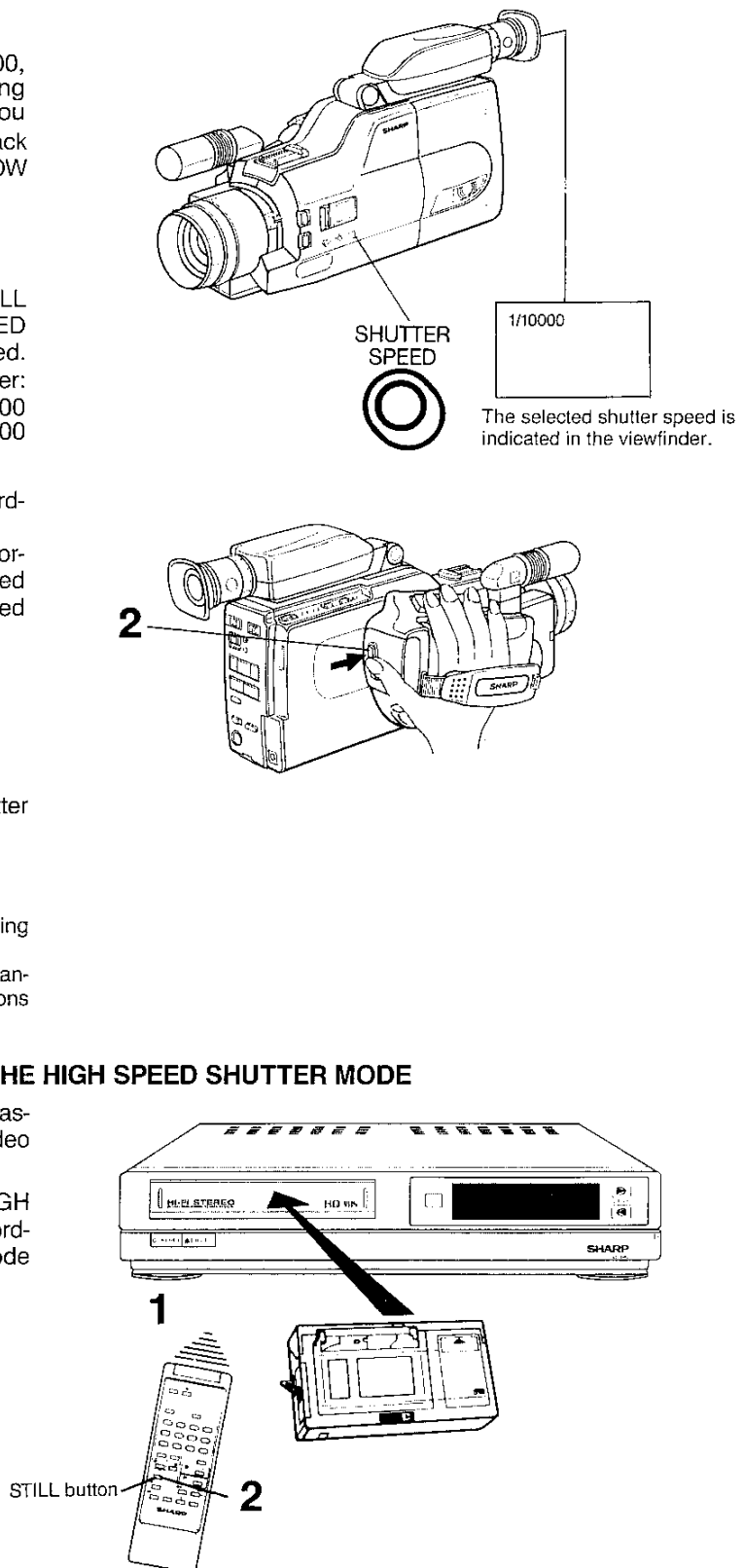

MACRO SHOTS

Small plants, insects, even photos in the family album can be recorded using Macro and enlarged to fill the screen. You can also use Macro to record titles for your videos.

Normally the lens can only focus on subjects that are more than 1.1 m away from the front of the Camcorder.

By setting the lens to Macro, you can manually focus on any subject within the macro range, 10mm-110cm, right up to the front of the lens.

Mount the Camcorder on a steady tripod as the smallest movement is magnified when shooting macro subjects.

- 1** Set the FOCUS button to MANUAL.
- 2** Hold the MACRO button down and turn and lock the zoom lever in the MACRO position.
- 3** Focus by slowly turning the zoom lever.

Notes

- Turn the zoom lever back to the normal focus range when you have finished with Macro.
- When recording a solid coloured object such as a flower petal, the colour may shift. In this event, use the white balance lock mode. (See page 30.)

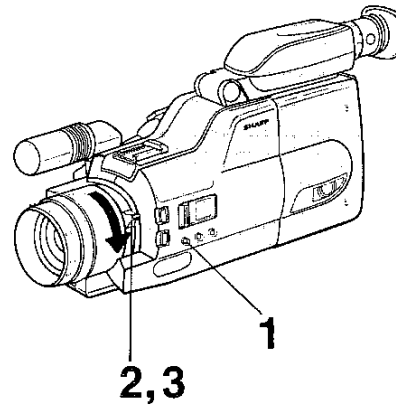

FADE IN & OUT

With this Camcorder you can enjoy the special effect of fading in and out of the scenes in your recordings.

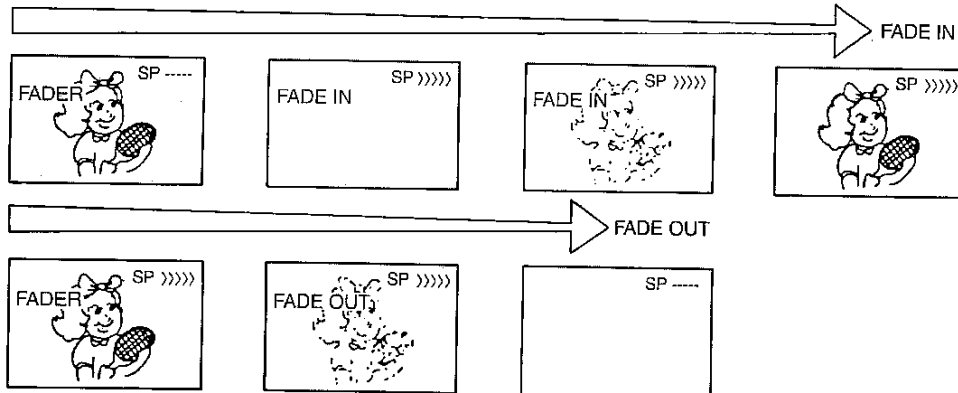

FADE IN

- 1** With REC PAUSE on, press the FADE IN/OUT button. The viewfinder will display "FADER".
- 2** Press the REC START/STOP button to start recording. The viewfinder will turn black, and then gradually focus on the subject. ("FADE IN" will appear in the viewfinder.)

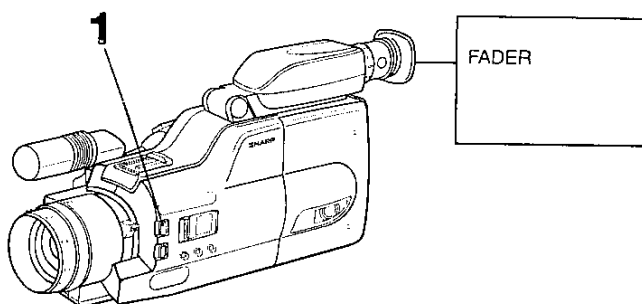

FADE OUT

- 1** While recording, press the FADE IN/OUT button. The viewfinder will display "FADER".
- 2** Press the REC START/STOP button. The viewfinder will slowly turn black creating a fade-out of the scene. ("FADE OUT" will appear in the viewfinder. If you select the REC PAUSE mode, the FADE will be cancelled.)

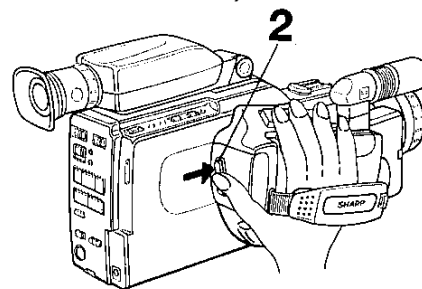

LIGHTING

LIGHTING

For clear good-quality pictures you will need between 500 and 100,000 lux — you can record in less light, however the picture quality may suffer. Adequate lighting is also essential for correct white balance.

Brightness	Situation
100,000 (Lux)	Blue sky Clear day at noon (100,000) Clear day at 10am (65,000)
10,000	Clear day at 3pm (35,000) Cloudy day at noon (32,000) Cloudy day at 10am (25,000)
1,000	Cloudy day, one hour after sunrise (2,000) Clear day, one hour before sunset (1,000) Fluorescent light near window (1,000)
	Factory floor (700-800) Sales counter in department store (500-700) Bowling alley (500) Library (400-500) Office with fluorescent lighting (400-500) Fluorescent desk lamp (400) Flashlight at 1m (250)
100	Shop stairway (100)
10	During intermission at movie theatre (15-35) Cigarette lighter at 30cm (15-20) Candles on birthday cake at 20cm (10-15)
	Candlelight

Colour Temperature	Situation	Colour	White Balance Range
10,000 (°K)	Clear day	Blue	A U T O
9,000	Colour TV		
8,000	Cloudy day		
7,000	Rainy day		
6,500	Daylight fluorescent light		
6,000	Camera flashbulb		
5,500			
5,000	Blue photolamp	White	
4,500	White fluorescent light		
3,500	Off-white fluorescent light Tungsten photolamp		
3,200	Halogen lamp		
2,800	Tungsten lamp Iodine lamp	Yellow	
2,500	Acetylene lamp Kerosene lamp		
2,000	Candlelight	Red	

Notes

- These are approximations.
- Auto White Balance should normally be used in the colour temperature range shown above. However it will satisfactorily operate from 2500°K up to 8000°K, but the picture may become redder or bluer, respectively.

Video Lighting

Lighting is one of the most important areas in home videos. Also one of the most overlooked. Good lighting can often mean the difference between a great picture and a poor quality one. And lighting is essential for correct white balance.

In most outdoor situations natural lighting is adequate for home videos. Indoors the situation becomes more complicated. Artificial lighting is required and tungsten (or quartz) lamps provide the most natural of artificial light sources, while providing a constant colour temperature over a long life.

Good lighting is difficult to achieve and there are many problems to catch the unwary. Simply mounting one light on or several lights either side of the camcorder will only make your subject look flat and two-dimensional. To make a subject more interesting, use the lighting to model your subject and to add or create emphasis in a scene.

BEFORE REQUESTING SERVICE

Before calling for servicing, please check the following troubleshooting table.

SYMPTOM		POSSIBLE CAUSE	SUGGESTED SOLUTION
• Power	• No power	• Safety devices are functioning.	• Disconnect the AC adaptor cord, and then plug it into the wall socket again.
		• The battery pack is not charged.	• Charge the battery pack sufficiently.
		• The power source unit is not correctly connected.	• Connect the power source unit correctly.
	• Power switches off soon after coming on.	• Depleted battery pack.	• Use a fully charged battery pack.
		• Dew in Camcorder.	• Wait until dew disappears.
• Recording.	• Power on but no image in viewfinder.	• Lens cap on.	• Remove the lens cap.
	• Can't record	• Recording prevention tab broken off from cassette. • CAMERA REC/VCR PLAY switch is set to "VCR PLAY".	• Cover the tab hole with adhesive tape or insert a cassette with its recording prevention tab intact. • Slide the CAMERA REC/VCR PLAY switch to "CAMERA REC".
	• Poor colour	• TV not properly adjusted.	• Adjust the TV.
		• Poor lighting.	• Apply additional lighting or correct colour temperature of lighting.
	• Fuzzy picture	• Dust or other foreign matter on lens.	• Clean the lens.
		• Not properly focused.	• Adjust the focus.
• Camera picture is too dark	• The SHUTTER SPEED select button is set to HIGH SPEED SHUTTER MODE.	• Set the SHUTTER SPEED select button to "STANDARD".	
• Playback	• No image appears.	• Improperly connected to TV.	• Reconnect properly.
		• The TV is not tuned to the RF converter's output channel (UHF30-39)	• Tune the TV to the RF converter's output channel (UHF30-39)
		• TV's TV/VIDEO switch is not at TV position (if the TV is equipped with AV input terminal)	• Set TV's TV/VIDEO switch to TV position.
	• Playback is in black and white when the Camcorder is connected to TV.	• Tracking not properly adjusted.	• Adjust the tracking.
	• Video noise in image.	• Old or worn tape.	• Use a new tape.
	• Broken image	• Insufficient battery capacity.	• Recharge the battery pack.
• Cassette can't be inserted.	• Cassette is not right side up or is backwards. • Another cassette is in the unit.	• Check cassette positioning and reinsert. • Press the EJECT button and remove.	
• No tape movement in fast forward mode.	• Tape is already completely wound.	• Rewind to desired point.	
• No tape movement in rewind mode.	• Tape is already completely rewound.	• Fast forward to desired point.	

Note This unit is equipped with a microprocessor. Its performance could be adversely affected by external noise or interference. If this were to happen, turn off the power, and unplug this unit from the power source.

SPECIFICATIONS

Format	VHS standard
Power source	DC 9.6V \pm
Power consumption	9.2W
Signal system	PAL-type colour signal
Recording system	Luminance: FM recording Colour: Converted sub-carrier direct recording Conforms to VHS standard
Cassette	VHS-C cassette
Tape speed (SP)	23.39 mm/sec
(LP)	11.69 mm/sec
Recording time Max. (SP)	30 minutes (with EC-30 cassette)
(LP)	60 minutes (with EC-30 cassette)
VIDEO Output	1.0 Vp-p, 75 ohms, unbalanced (via AV out connector)
S/N ratio	46 dB (with Rohde & Schwarz noise meter)
AUDIO Output	-8 dBs, 1k-ohm (via AV out connector)
Microphone input	-65 dBs, high impedance, unbalanced
Pickup	1/2" -format CCD
Minimum required illumination	3 lux (at F 1.6, with Gain up)
Lens	F1.6, f=8-64 mm, 8 \times power zoom lens with auto iris control and macro position, filter diameter 46mm.
Viewfinder	Colour viewfinder (0.7" LCD)
Colour temperature compensation	Auto white balance with white balance lock
Operating temperature	0°C to 40°C
Operating humidity	35% ~ 80%
Storage temperature	-20°C to 60°C
Weight	1.2 kg (with viewfinder)
Dimensions	126(W) \times 160(H) \times 326(D) mm (incl. viewfinder)

AC power adaptor/Battery charger specifications

Power requirement	AC 110V — 240V, ~50/60Hz
Rated output voltage	DC 9.6V \pm
Rated output current	1.3A
Charging system	Constant current, peak detection, timer controlled
Dimensions	70(W) \times 43(H) \times 154(D) mm
Weight	Approx. 380g

SUPPLIED ACCESSORIES

Standard battery pack (BT-75)	Shoulder strap
AC power adaptor/battery charger (AA-75S)	DC output cable
A/V output cable (21-pin Euro-SCART)	Lithium battery

OPTIONAL ACCESSORIES

Standard battery pack (BT-75)	Battery pack for extended use (BT-76)	RF converter (VR-S10RF)
Car battery adaptor/charger (VR-P75CH)	VHS cassette adaptor (VR-72CA)	Zoom microphone (VR-67ZM)

Design and specifications are subject to change without notice.

SHARP CORPORATION

Osaka, Japan

Printed in Japan
In Japan gedruckt
Imprimé au Japon
Trykt i Japan
Stampato in Giappone
Impreso en Japón
Gedruckt in Japan
Impresso no Japão
TINSLO020TAZZ
T7988-A