

Universal Applicator with Lift Cylinder

1005

2 Operator's Manual - Translation of the Original Version for the following products

2

Part-No.	Description	Type
5950250	Tamp-Applicator	1005L-100H
5950253	Tamp-Applicator	1005R-100H
5950309	Tamp-Applicator	1005L-150H
5950251	Tamp-Applicator	1005L-220H
5950254	Tamp-Applicator	1005R-220H
5950252	Tamp-Applicator	1005L-300H
5950255	Tamp-Applicator	1005R-300H
5950308	Tamp-Applicator	1005L-400H
5950365	Tamp-Applicator	1005R-400H

Edition: 03/2010 - Part.-No. 9008592

Copyright

This documentation as well as translation hereof are property of cab Produkttechnik GmbH & Co. KG.

The replication, conversion, duplication or divulgement of the whole manual or parts of it for other intentions than its original intended purpose - in particular the procurement of spare parts for products sold by cab - demand the previous written authorization by cab.

Trademark

Centronics® is a registered trademark of the Data Computer Corporation.

Microsoft® is a registered trademark of the Microsoft Corporation.

Windows 2000®, 2003®, XP® are registered trademarks of the Microsoft Corporation.

TrueType™ is a registered trademark of Apple Computer, Inc.

Editor

Regarding questions or comments please contact cab Produkttechnik GmbH & Co. KG.

Topicality

Due to the constant further development of our products discrepancies between documentation and product can occur.

Please check www.cab.de for the latest update.

Terms and conditions

Deliveries and performances are effected under the General conditions of sale of cab.

Germany

cab Produkttechnik
GmbH & Co KG
Postfach 1904
D-76007 Karlsruhe
Wilhelm-Schickard-Str. 14
D-76131 Karlsruhe
Telefon +49 721 6626-0
Telefax +49 721 6626-249
www.cab.de
info@cab.de

France

cab technologies s.a.r.l.
F-67350 Niedermodern
Téléphone +33 388 722 501
www.cab.de
info@cab-technologies.fr

España

cab España S.L.
E-08304 Montaró (Barcelona)
Teléfono +34 937 414 605
www.cab.de
info@cabsl.com

USA

cab Technology Inc.
Tyngsboro MA, 01879
Phone +1 978 649 0293
www.cabtechn.com
info@cabtechn.com

South Afrika

cab Technology (Pty.) Ltd.
2125 Randburg
Phone +27 11-886-3580
www.cab.de
info@cabtechn.co.za

Asia 亞洲分公司

希愛比科技股份有限公司
cab Technology Co, Ltd.
台灣台北縣中和市中正路700號9F-8
Junghe 23552, Taipei, Taiwan
電話 Phone +886 2 8227 3966
網址 www.cabasia.net
詢問 cabasia@cab.de

China 中國

銳博(上海)貿易有限公司
cab (Shanghai) Trading Co.,Ltd
上海市延安西路2299號11C60室
電話 Phone +86 21 6236-3161
詢問 cabasia@cab.de

Representatives in other countries on request.

1	Introduction	4
1.1	Instructions	4
1.2	Intended Use	4
1.3	Safety Instructions.....	4
1.4	Safety Marking	5
1.5	Environment.....	5
2	Product Description.....	6
2.1	Function	6
2.2	Device Overview	7
3	Installation	8
3.1	Delivery Of The Applicator	8
3.2	Mounting Applicator.....	8
3.2.1	Attach Applicator At Printer	8
3.2.2	Connections	9
3.2.3	Mounting Pad.....	9
4	Adjustments	10
4.1	Mechanical Adjustments	10
4.1.1	Adjustment - Pad Position	10
4.1.2	Adjustment - Air Tube.....	11
4.1.3	Adjustment - Lift Length	11
4.2	Pneumatic Adjustments.....	12
4.2.1	Set Valves	12
4.2.2	Slide Valve	12
4.2.3	Throttle Valves At The Valve Block.....	12
4.2.4	Throttle Valve At The Cylinder.....	13
5	Operation	14
5.1	Setting The Operating Mode And Delay Times	14
5.1.1	DIP-Switches.....	14
5.1.2	Potentiometer.....	14
5.1.3	Read Settings Of Potentiometers.....	15
5.1.4	Operating Mode	15
5.2	Pre-Dispense Key	16
5.3	Peel Position	17
5.4	Normal Operation.....	17
6	PLC Interface	18
6.1	Comments On The Signals	18
6.2	Circuit Diagrams Of Inputs And Outputs	20
6.3	Examples For Circuits To Creating An External Start Signal.....	21
7	Error Messages	23
7.1	Printer Error Messages	23
7.2	Applicator Error Messages.....	23
8	Function Of The LED's On The PCB.....	24
9	Declaration.....	25
9.1	EC Declaration of Incorporation	25
9.2	EC Declaration of Conformity.....	26
10	Index.....	27

1.1 Instructions

Important information and instructions in this documentation are designated as follows:



Danger!

Draws your attention to an exceptionally grave, impending danger to your health or life.



Warning!

Indicates a hazardous situation that could lead to injuries or material damage.



Attention!

Draws attention to possible dangers, material damage or loss of quality.



Notice!

Gives you tips. They make a working sequence easier or draw attention to important working processes.



Environment!

Gives you tips on protecting the environment.



Handling instruction



Reference to section, position, illustration number or document.



Option (accessories, peripheral equipment, special fittings).

zeit Information in the display.

1.2 Intended Use

- The device is manufactured in accordance with the current technological status and the recognized safety rules. However, danger to the life and limb of the user or third parties and/or damage to the device and other tangible assets can arise during use.
- The device may only be used for its intended purpose and if it is in perfect working order, and it must be used with regard to safety and dangers as stated in the operating manual.
- The device is developed to work in a system with a **Hermes A** printer
- The device applicator is intended exclusively for labeling suitable materials that have been approved by the manufacturer. Any other use or use going beyond this shall be regarded as improper use. The manufacturer/supplier shall not be liable for damage resulting from unauthorized use; the user shall bear the risk alone.
- Usage for the intended purpose also includes complying with the operating manual, including the manufacturer's maintenance recommendations and specifications.



Notice!

The complete documentation is currently in the Internet.

1.3 Safety Instructions

- Only connect the device to other devices which have a protective low voltage.
- Switch off all affected devices (computer, printer, accessories) before connecting or disconnecting.
- The device may only be used in a dry environment, do not expose it to moisture (sprays of water, mists, etc.).



Warning!

Make sure that the printer is disconnected from the power supply and the valve at the service unit as well as the shutoff valve at the applicator are closed, while installing the delivered components.



Warning!

In operation, moving parts are easily accessible. Therefore, keep long hair, loose clothes and jewelry distant. Before any manipulations in those areas, close the shutoff valve.



Warning!
Do not try to manipulate or repair parts they are not described in the manuals of the tamp applicator or the printer.

1.4 Safety Marking

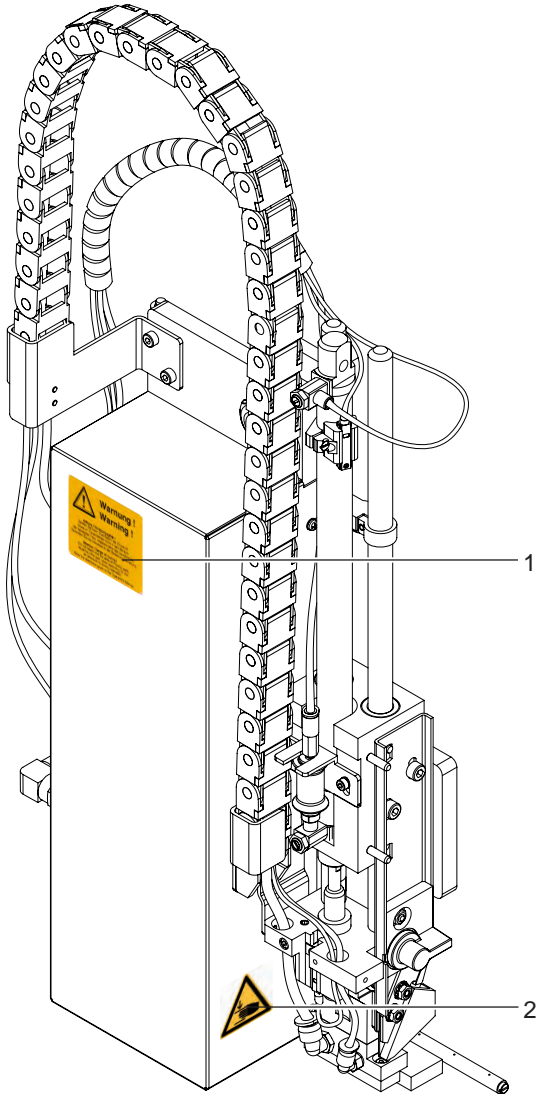

1:

Risk of injury by moved parts

2:

Danger of bruise by the moving pad.

Figure 1 Safety marking

1.5 Environment



Obsolete devices contain valuable recyclable materials that should be sent for recycling.

- ▶ Send to suitable collection points, separately from residual waste.

The modular construction of the printer enables it to be easily disassembled into its component parts.

- ▶ Send the parts for recycling.

The electronic circuit board of the device is equipped with a lithium battery.

2.1 Function

The universal tamp applicator **1005** is an additional module for the transfer printer **Hermes A**. It's developed for the automatically apply a label onto a product.

To apply the label the applicator used a Tamp, which moved between a take-over position and a labeling position by a pneumatic cylinder.

In the take over position the tamp get the label from printer. In the take-over position, the label is picked up from the printer by the vacuum plate of the pad. A sensor at the cylinder signals when the pad is in the take-over position.

The label is removed from the carrier ribbon directly at the dispense edge of the printer. It is sucked on the pad by a vacuum via drill-holes at the bottom of the pad. For support, the label is also blown against the pad with an air current coming from a blow tube. The correct transfer of the label is controlled by a vacuum sensor. Next, the pad is moved down into the labelling position, which is confirmed by another sensor (labelling position sensor). Here, the label is stamped onto the product. While the pad is moving back into the starting position, the vacuum sensor controls whether the label has been removed from the pad. Specially adapted pads can be used for different label sizes.

The label transfer to the product is possible in two options :

- **Stamp**

The label will be impressed at the unmoved product by pad.

Special case : Labeling of rotating cylindrical products.

- **Blow**

The pad will move into a defined position over the product. This position must be approximately 10mm to the product surface. The label will put at the product by blow air.

While the pad is moving back into the starting position, the vacuum sensor controls whether the label has been removed from the pad.

Supporting air, vacuum and cylinder speed are adjustable. So it's possible to accommodate the system to different label sizes.

For operation in a superior system the applicator's PLC (programmable logic control) interface with potential free inputs and outputs can be used.

Label transfer	Stamp	Blow
Label width in mm	8 - 116	10 - 116
Label height in mm	5 - 80	10 - 80
Cylinder stroke in mm	100 - 400	
Compressed air supply	0,5 - 0,6 MPa (5 - 6 bar)	
Product surface	flat, cylindrical (rotating)	flat
Product height		
variable	■	-
fixed	-	■
Product		
stationary	■	■
moving	-	■
rotating	■	-
Cycle time		
Labeling per min.	approx. 30	

Table 1 Technical data

2.2 Device Overview

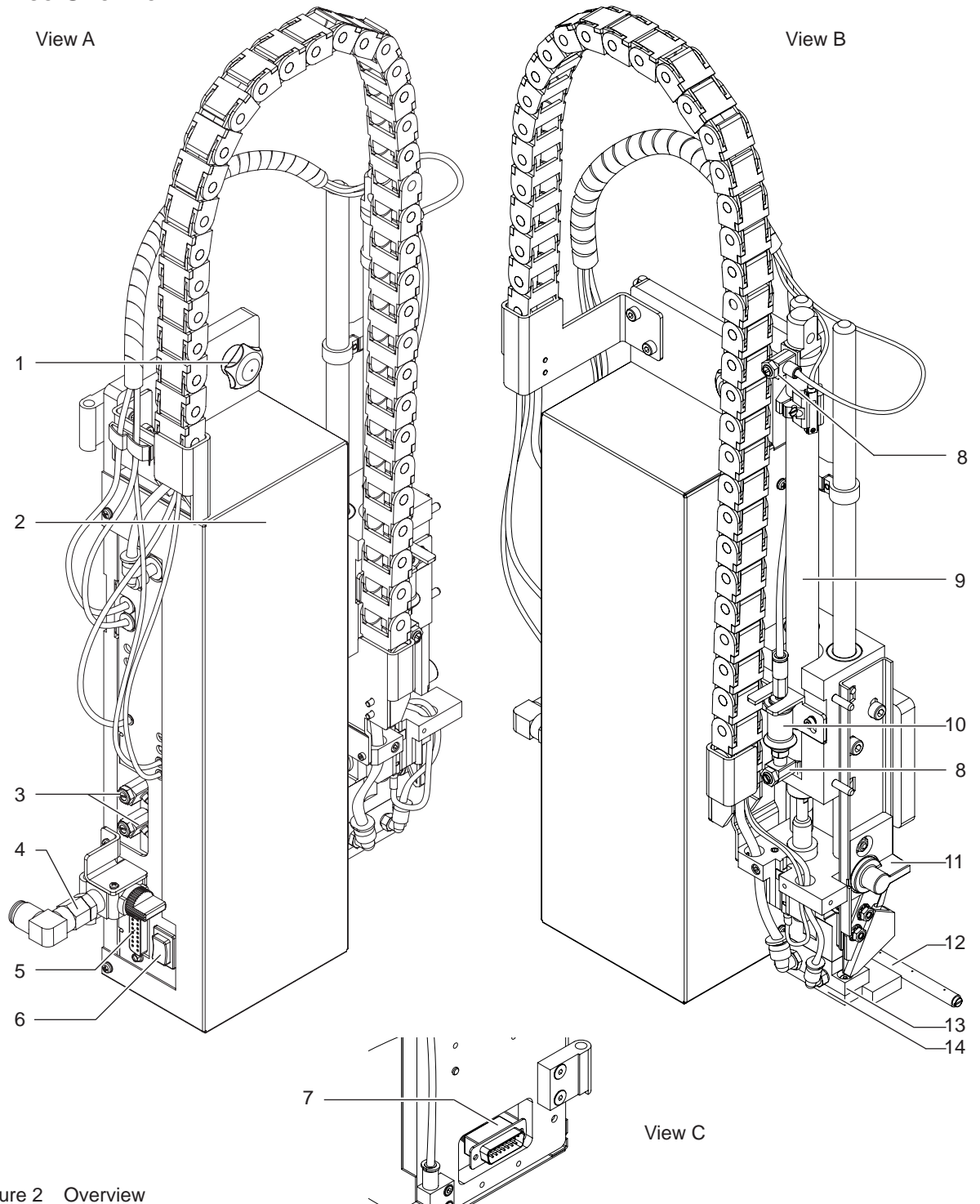

Figure 2 Overview

- 1 Thumbscrew
- 2 Cover
- 3 Throttle valve supporting air and vacuum
- 4 Connector compressed air
- 5 PLC-interface
- 6 Pre dispense key
- 7 Connector applicator-printer

- 8 Throttle valve cylinder
- 9 Cylinder
- 10 Slide valve
- 11 Lever, fixing tamp assembly
- 12 Blow tube (* customized)
- 13 Adapter tamp
- 14 tamp (* customized)

3.1 Delivery Of The Applicator

- Check the applicator at transport damage and totality.

Scope of delivery:

- Applicator
- Pad and blow tube
- Hinges and screws
- Documentation



Notice!

Please keep the original packaging in case the printer must be returned.



Notice!

Before initial operation unlock the pad assembly via lever. Pull and rotate the lever to unlock. (► Figure 2)

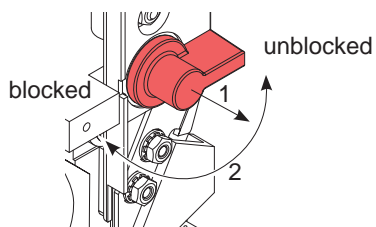

Figure 3 Transport-locking

3.2 Mounting Applicator



Attention!

Mounting and installation the applicator only if the printer switched of.



Warning!

Risk of injury and damage in case of using the applicator not appropriate.
Use the applicator only secure mounted at a Hermes A - printer.

3.2.1 Attach Applicator At Printer

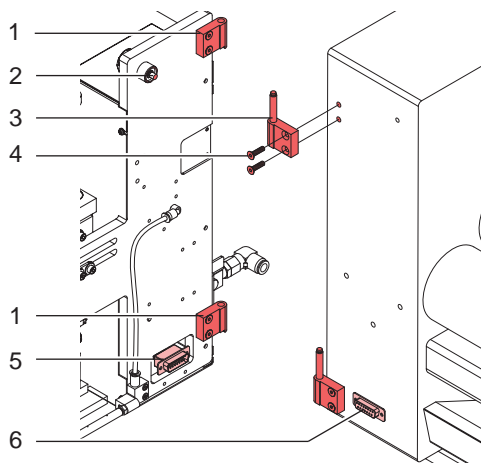

1. Axle part of hinges (3) mount like Figure 3 .
2. Applicator hang with the female part (1) of hinges at the printer mounted hinges parts (3).

Figure 4 Mounting and connecting

3.2.2 Connections

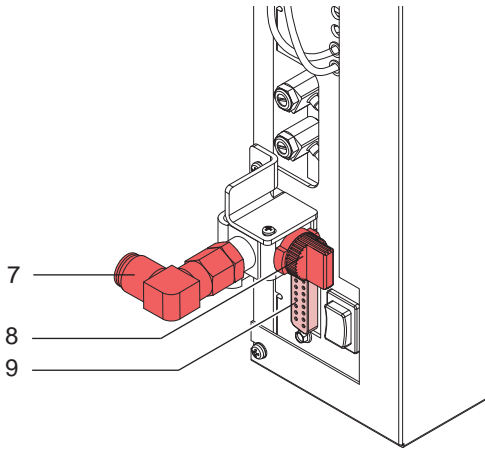

1. Connect SUB-D 15 male connector (Figure 3-5) to the female connector (Figure 3-6) of the printer.
2. Swing the applicator to the printer and tighten the thumb-screw (Figure 3-2).
3. Check the vertical position of the stop valve (8). (stop valve closed)
4. Attach compressed air at the fitting (7).
5. Connect the PLC-interface (9) via 15-pin female connector. (PLC-Interface)

Figure 5 Connections

3.2.3 Mounting Pad

Pad Type 11xx and 21xx

Mount pad (3) with added screws (1) like Figure 5.

Pad Type 12xx

1. Loosen screws (11).
2. Disconnect tubes (4 and 5) from adapter (2) and take out adapter (2).
3. Put pad (9) at the pins (8) of the pad holder (7).
4. Tighten the pad (9) via screws (11) at the pad holder (7).
5. Push in the tube (5) for the vacuum in push in fitting (10).
6. Push tube (4) for blow at the pin (6) on pad holder (7).

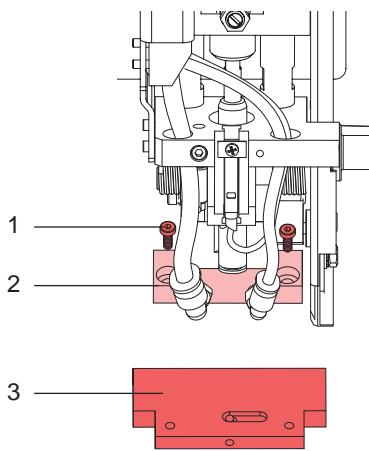

Pad Type 11xx and 21xx

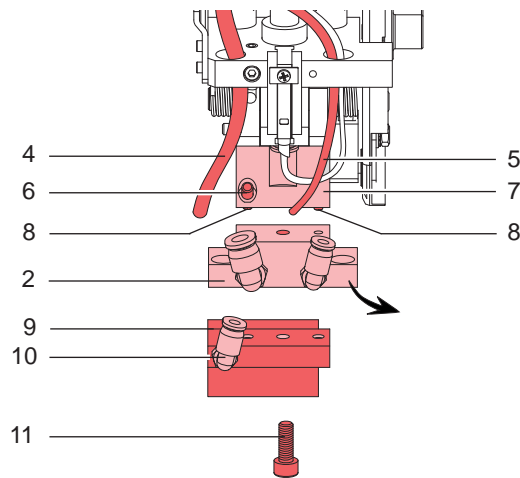

Pad Type 12xx

Figure 6 Mounting the pads

4.1 Mechanical Adjustments

4.1.1 Adjustment - Pad Position

An exact adjustment of the pad position in the start- or take-over position of the applicator is necessary to get a faultless transfer of the label between printer and applicator.

For orientation the pad, put in the material like the operators manual of the printer.

Look for the right size of labels to the pad!

- ▶ Open the compressed air supply.
- ▶ Switch-on the printer.

The pad will moved to the take-over position.

Adjustment - Blade angle, pad to dispense plate (printer)

A leading (9) mounted at the mounting bracket (6) defined the blade angle and in follow the distance between dispense plate and pad edge.

1. Loosen nuts (7) to unfasten the stopper (8).
2. Loosen screws (4).
3. Move the mounting bracket (6) that the edge of the pad (1) and the dispense plate edge (2) are in a vertical line.
4. Tighten screws (4).
5. Move stopper (8) so, that a gap (max. 0.5mm) is between stopper and ball bearing.



Attention!

The stopper (8) is used to obviation an over swing of the tamp. Is not to use to adjust a tamp position.

6. Fasten nuts (7).

Adjustment - Height of the pad in take-over position

1. Loosen screws (3).
2. Move the pad assembly in vertical direction. The vertical distance (B) between pad edge and dispense plate must be approx. 1mm.
3. Tighten screws (3).

Adjustment - Horizontal pad position

1. Loosen screws (5).
2. Move the pad assembly in horizontal direction. The center of the pad must be direct over the center of the label.
3. Tighten screws (5).

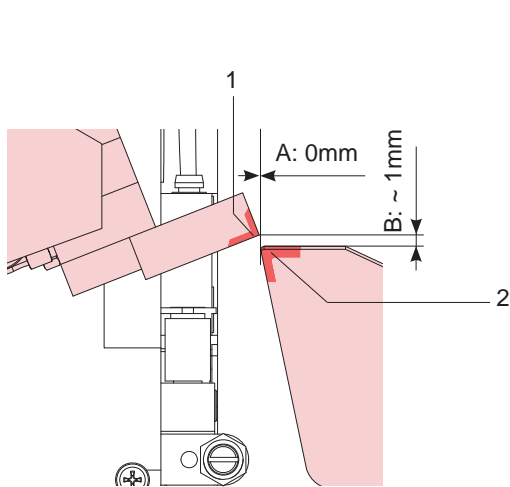
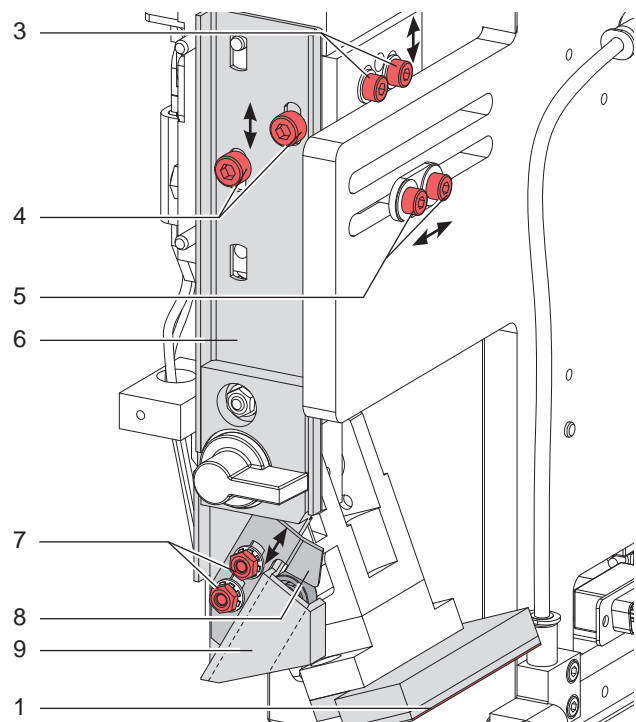

Figure 7 Adjust pad position



Angle adjustment between pad and product

To assure an exactly labeling it's necessary that the pad pressure is planar at the product surface.

Setscrew (1) in combination with pin (3) defined the angle of the pad.

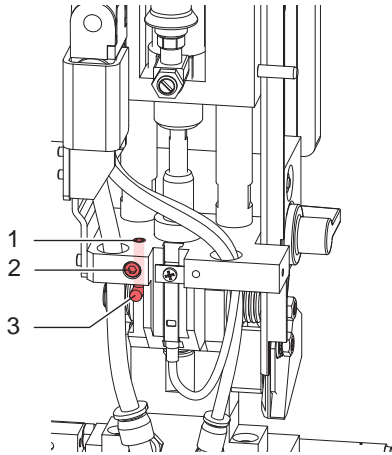

1. Close compressed air supply and de-aerate the cylinder (▷ Slide valve)
2. Move the pad to the product.
3. Loosen screws (2).
4. Change setscrew (1)
 - Clockwise → pad swing to the printer.
 - Counterclockwise → pad swing in print direction.
5. Tighten screw (2) to fix set screw (1).
6. Close slide valve and open the compressed air supply.

Figure 8 Adjust the pad angle in apply position

4.1.2 Adjustment - Air Tube

It is possible to change the direction of supporting air by rotating the air tube (2).

1. Hold the slotted screw (3) with a screwdriver and loosen the counter nut (1).
2. Adjust the tube until the air current is aligned with the dispense edge (4) of the printer.
3. Tighten the counter nut.

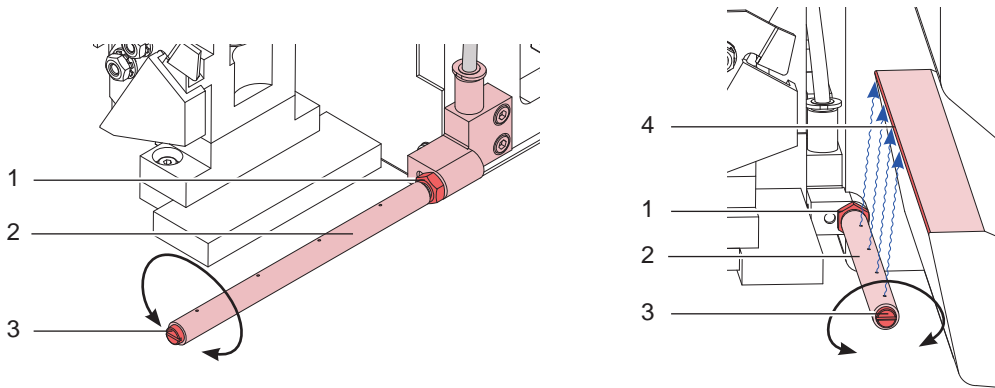
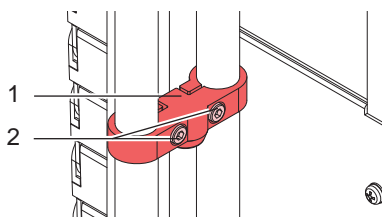

Figure 9 Adjust the air tube

4.1.3 Adjustment - Lift Length

If the applicator works in the "Blow" mode it's necessary to change the cylinder stroke. The blow on of the label will start after a signal from the label sensor. The distance between pad and product must be approx. 10 mm.



1. Loosen screws (2).
2. Move stopper (1) to change the lift length
 - down → make lift length shorter
 - upside → make lift length longer
3. Tighten screws (2).

Figure 10 Lift length (Labeling mode: "Blow")

4.2 Pneumatic Adjustments

4.2.1 Set Valves

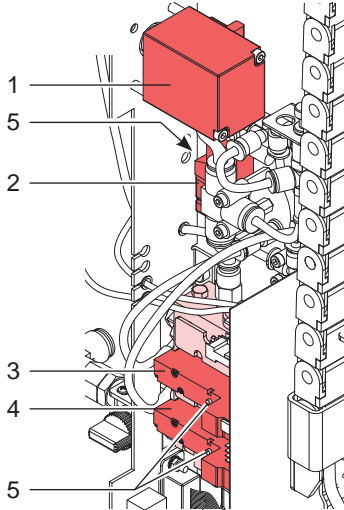

- Valve (1) to control the blow air.
- Valve (2) to control the lift cylinder.
- Valve (3) to control the supporting air.
- Valve (4) to control the vacuum.

These valves will be triggered by electrical signals in normal operation.
The vacuum valve (4), supporting air valve (3) and lift cylinder valve (2) are also triggered by hand via the micro switches (5).

Remove the cover for triggering the valves (3 and 4) by hand .
(▷ Operation)

Figure 11 Set valves

4.2.2 Slide Valve

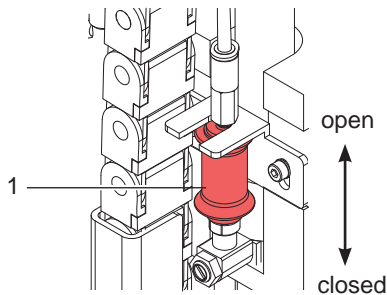

Slide valve (1) is a manual operated valve, which can de-aerate the cylinder for repair- and service operation.
So it's possible to move the pad assembly in case the system is switched off.
Through moving up the ring it will be open the valve to de-aerate the cylinder.

Figure 12 Slide valve



Warning!

Use the slide valve only if the compressed air supply is locked.
Control that the slide valve is closed before start the labeling operation.

4.2.3 Throttle Valves At The Valve Block

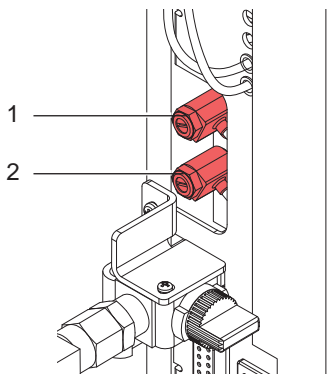

Throttle valve - supporting air (1)

Over this valve the supporting air can be changed.
The valve is adjusted at the throttle screw.
Turn in the clockwise direction closes the valve.
The valve has to be tuned in such a way, that the label is blown onto the pad without turning or swinging.

Throttle valve - vacuum (2)

With this valve the vacuum to suck the label onto the pad can be adjusted.
Turn the throttle screw to adjust the valve.
Turning clockwise will close the valve.

Figure 13 Throttle valves at the valve block

4.2.4 Throttle Valve At The Cylinder

**Notice!**

In case the cylinder movement needs longer 2 sec the system will break up the operation.

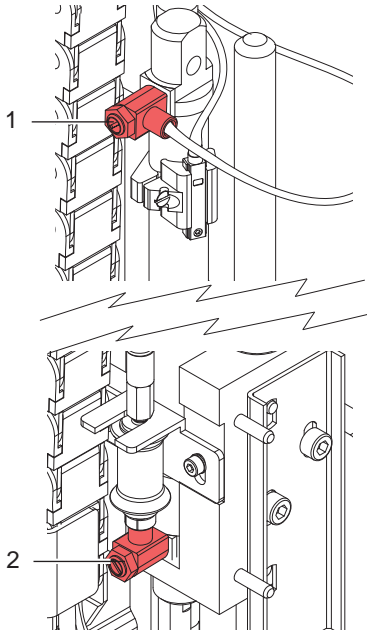

Figure 14 Throttle valve at the cylinder

Throttle valve cylinder - up (1)

Over this valve the speed of cylinder movement (drive-in direction/up) can be changed.

The valve is adjusted at the throttle screw.

Turn in the clockwise direction closes the valve. The speed will be reduced.

Throttle valve cylinder - down (2)

Over this valve the speed of cylinder movement (drive-out direction/down) can be changed.

The valve is adjusted at the throttle screw.

Turn in the clockwise direction closes the valve. The speed will be reduced.

5.1 Setting The Operating Mode And Delay Times

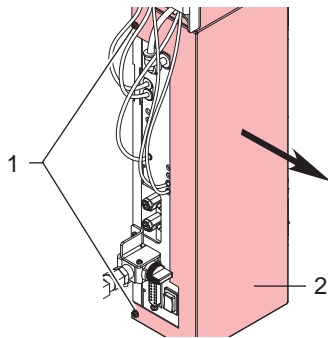

Figure 15 Cover

It is possible to use the applicator in different operating modes. These modes are different in apply the label to the product (stamp/blow) and the sequence of operation (print/apply or apply/print).

After removing the cover (2) of the manifold, 6 potentiometers (Figure 17) as well as 4 DIP switches (Figure 16) become accessible by which the parameters can be set.

To remove the cover (2) loosen screws (1).

5.1.1 DIP-Switches

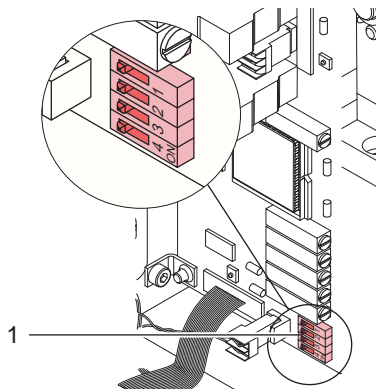

Figure 16 DIP-switches

DIP-switch	Parameter	ON	OFF
1	stand by position (only if DIP-2 : OFF and DIP-3 : OFF)	up	down
2	kind of application	stamp	blow
3	operating mode	print/apply	apply/print
4	save values of potentiometers (▷ 5.3 Read settings of potentiometers)	no	yes

Table 2 Parameter of DIP-switches

If switch No. 4 is OFF the setting of the potentiometers is automatically stored in the Hermes A when switched on. Therefore, in case the applicator has been changed (e.g. in case of an accident) the settings are still saved and can be transferred to a replacement. (▷ Read settings of potentiometers)

5.1.2 Potentiometer



Notice!

In case of changing a parameter by a potentiometer, the value of this parameter will displayed at the printer display for short time.

Potentiometer 1 is sealed. Certain voltage settings are pre-adjusted from the factory and not to be changed by the user.

Potentiometer (2) : t_b - blowing time 0...2.5 s

This potentiometer is used to set the time period of the blow air for transfer of the label onto the product.

Potentiometer 3 : t_{SA} - switch-off delay supporting air 0 ... 2.5 s

Delayed to the process of the label being picked up, the supporting air is switched off. In many cases, after being picked up by the pad the label edge may still stick on the silicon liner. This may affect the accuracy of the label positioning or even cause labelling faults. Therefore, switching off the supporting air delayed may be useful to separate the label from the carrier ribbon and place it neatly on the surface of the pad.

Potentiometer 4 : s_{SE} - switch-on delay supporting air 0 ... 20 mm

The supporting air from the blow tube is not immediately switched on when the print of the label is released but delayed, when the label has covered a certain distance s_{SE} . This delay helps to prevent a turning or swinging at the front of the label and, consequently, avoids faults when the label is picked up from the printer.

The parameter measures the distance covered by the label before the supporting air is switched on, and does not depend on the print speed. This way, the position of the label may be determined until the air is switched on.

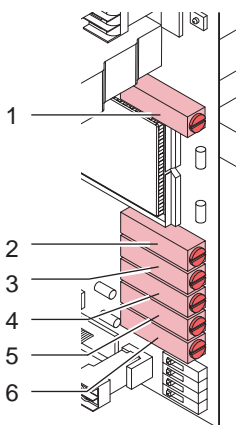

Figure 17 Potentiometer

Potentiometer 5 : t_{SP} - locking time 0 ... 2.5 s

All start signals coming in following the first start signal are ignored when they arrive within the locking time t_{SP} . It's used for debouncing of the start signal.

Potentiometer 6 : t_{VS} - start delay 0 ... 2.5 s

The parameter t_{VS} determines the time period between the start signal and the start of the labelling process. This delay makes it possible to release the start of the process controlled by a sensor, for instance, when a sensor is located within an assembly line in front of the labelling place.

5.1.3 Read Settings Of Potentiometers



Notice!

In case the applicator has been changed (e.g. in case of a malfunction) the stored parameters can be viewed as described above and the new device can be adjusted accordingly. For that purpose the DIP-switch 4 at the new applicator has to be 'ON' during switching on the device the first time.

The takeover the values of a changed applicator will be manually by comparison with the saved values.

1. Read values - press and hold pressed the key **MODE** of the printer's navigator pad. After approx. 3 seconds it will displayed the 'short status'. To got back the main menu press the key .
2. The setting of the five delay times is displayed by pressing the key or the key .
3. Change the value at the corresponding potentiometer.
The current value will displayed at the printer display.
4. To read an other value start again from step 1.
5. Are the settings finished, switch the DIP-switch 4 of the new applicator at the position 'OFF' to record possible later settings.

5.1.4 Operating Mode

The operation of the applicator can warden while maintaining the operational sequence in principle by parameter attitudes in control electronics modified.

Moreover exist a special mode for setting by using the pre dispense key.

Operating mode 'printing / labelling'

The print of a label is released by an external start signal (via PLC interface). At the same moment the vacuum on the pad as well as the supporting air from the blow tube are switched on. When the label is printed and picked up from the carrier ribbon, the supporting air is switched off. Then the lift cylinder is driven to move the pad down towards the labelling position. A sensor signals when the labelling position is reached. Following, the vacuum is switched off and the label is placed onto the product by the pressure of the stamp. After that, the lift cylinder is driven to move the pad back into the starting position. Thus, the labelling cycle is finished.

Operating mode 'labelling / printing'

Before starting the mode 'labelling / printing' the printing and picking up of the first label has to be released separately by a special signal (via PLC interface). The pad with the printed label is in the starting position. The vacuum on the pad is switched on. By an external start signal the lift cylinder is driven to move the pad down into the labelling position. The sensor signals when the labelling position is reached. In the following, the vacuum is switched off and the label is placed onto the product by the pressure of the stamp. After that, the lift cylinder is driven to move the pad back into the starting position. The print of the next label is released. At the same moment the vacuum on the pad as well as the supporting air are switched on. When the label is printed and picked up, the supporting air is switched off. Thus, the labelling cycle is finished.

5.2 Pre-Dispense Key

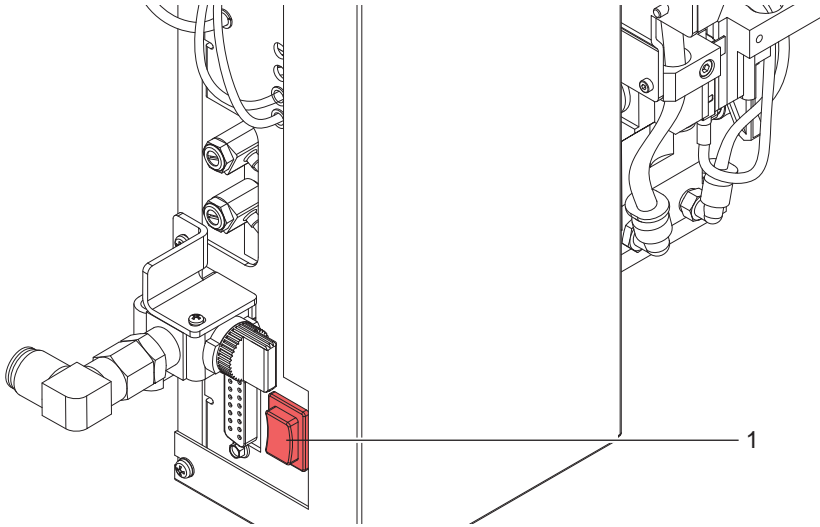

Figure 18 Pre-dispense key

Without print job

The whole labelling process can be simulated without the need of a print job or a connection to a computer by alternately pressing the key **FEED** and the pre-dispense key (1).



Notice!

Please use that test mode to adjust the parameter "Peel position" in the printer configuration !

If the printer has no print job, pressing the key **FEED** respectively the key will release the feed of a blank label. At the same moment the vacuum at the pad as well as the supporting air (blow tube) are switched on. After the label has been picked up by the pad, the supporting air is switched off. Pressing the pre-dispense key (1) will drive the lift cylinder to move the pad down into the labelling position. A sensor signals when the labelling position is reached. Following, the vacuum is switched off and the label is placed onto the product. Then, the lift cylinder is driven to move the pad back into the starting position.

With print job

By pressing the pre-dispense key (1), half cycles of the labelling process can alternately be released, provided that there is a print job.

- **1(st) half cycle**

Pressing the key will release the print of one label. At the same moment the vacuum at the pad as well as the supporting air (blow tube) are switched on. After the label has been printed and picked up by the pad, the supporting air is switched off.

- **2(nd) half cycle**

Pressing the key will drive the lift cylinder to move the pad down into the labelling position. The sensor signals when the labelling position is reached. Following, the vacuum is switched off and the label is placed onto the product. Then, the lift cylinder is driven to move the pad back into the starting position.

5.3 Peel Position

To set the peel position, the accurate position of the label to take over the label from printer to the pad, the system offers two possibilities.



Notice!

The two-part procedure to set the peel position is very important for a restart after put in material and after troubleshooting. It's possible that if so the software setting of peel position don't respond.

Peel position in the printer configuration

The first option to adjust the peel position offers the printer configuration. (▷ Operators manual of the printer). This option should be the first step and generate the basic adjustment.

The whole labelling process can be simulated without the need of a print job or a connection to a computer by alternately pressing the key **[FEED]** and the pre-dispense key.

Peel position in the software

A second peel-off parameter is available in the software. The software value does not replace the value of the printer configuration but it serves the fine adjustment of the peel position for the current print job. The values from printer configuration and from software are added together for execution.

The **P-command** (Set Peel-Off Mode) is described in the programmer manual.

Check the adjustment of the peel position in the software by printing out test prints with the label to be applied. Adjust the software parameter with a real print job in such a way, That the printed labels are totally peeled-off from the liner.

5.4 Normal Operation

1. Check all external connections before starting to print.
2. Load the media corresponding to the instructions in the operator's manual of the Hermes A (chapter 'Media Loading'). Make sure that the locking system (printhead) is locked.



Notice!

Make sure that the pad is not covered by a label when switching on.

3. Open the shutoff valve.
4. Switch on the printer.
5. Before starting the first print job press the key **[FEED]** on the printer. This generates a synchronous running. Remove the processed labels manually. After a few seconds the printer carries out a brief rewind and the edge of the next label is positioned at the print line. This synchronizing also has to be carried out when the print job has been interrupted with the key **[CANCEL]** or open and close the printhead locking system.



Notice!

It is not necessary to make a synchronous running in case the printhead locking system wasn't opened. Also the printer was switched off only.

6. Start the print job.
7. Start the labeling process via PLC interface.

If an error occurs while the applicator is operating, this is shown in the display of the Hermes A.

(▷ Error message)

For use in a net worked system the applicator is equipped with a PLC interface to start and interrupt the labelling process. It also passes on state information as well as error messages of the applicator to the system control. The interface has a 15 pin SUB-D connector.

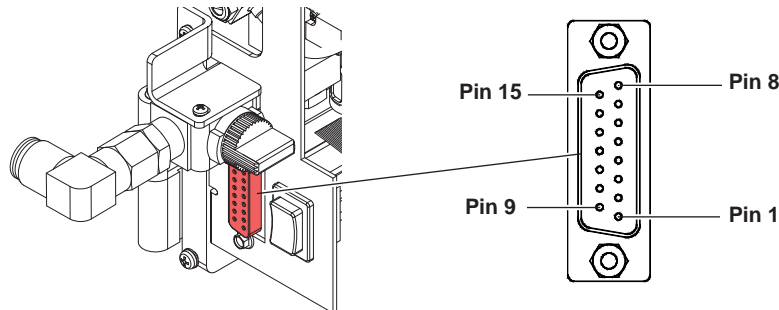

Figure 19 Female connector of the PLC interface



Attention!

To avoid faulty signals use a shielded cable for an external control system.

6.1 Comments On The Signals

Pin	Signal	Description	Activation / Active state
1	XSTRT ⊙→	Start signal Signal run the labelling process	It is active when +24V between Pin 1 and Pin 9.
2	XSTP ⊙→	Stop signal It releases following functions : <ul style="list-style-type: none"> to finish the print of a label and its picking-up by the pad to interrupt or to stop the beginning of the labelling process to make the pad moving back into the starting position to command the disregard of all following signals if the stop signal has been activated during the labelling phase, the display will show the message 'Host stop/ error' (does not show message during print process). 	It is active when +24V between Pin 2 and Pin 10.
3	XDREE ⊙→	Print first label 'Labelling / Printing' When the labelling process is started by the XSTRT signal within the operation mode 'Labelling / Printing', the cylinder will start to place the label onto the product at once. Only after that, a new label is printed. Therefore, the provision of the first label has to be assigned by a separate signal. 'Printing/Labelling' Signal has no function	It is active when +24V between Pin 3 and Pin 11.
4	XDNB ⊙→	Printer not ready This is an error message of the printer. The details and type of error can be learnt from the printer display. ('Ribbon out'; 'Paper out'; 'No label') After troubleshooting, the print of the last label will be repeated.	Contact between Pin 4 and Pin 14 (RUEL) is opened.

Table 3 PLC - connector pin assignment











Pin	Signal	Description	Activation / Active state
5	XEDG 	No existing print job State message. There is no print job currently available.	Contact between Pin 5 and Pin 14 (RUEL) is opened.
6	XSAA 	General error message General error message of both, printer and applicator. This message is shown when one of the two errors either XDNB or XETF occurs. This signal is important in case that only one error signal of the applicator can be analyzed from the system control.	Contact between Pin 6 and Pin 14 (RUEL) is opened.
7	XSOE 	Pad in starting position The signal is active when the pad is in the starting position where it picks up the label from the printer.	Contact between Pin 7 and Pin 14 (RUEL) is opened.
8	GND 	Grounding	0V
9	XSTRTR 	Reverse line to the start signal XSTRT	
10	XSTPR 	Reverse line to the stop signal XSTP	
11	XDREER 	Reverse line to the 'print first label' signal XDREE	
12	XSUE 	Pad in labelling position The signal is active when the pad is in its labelling position where the label is removed from the vacuum plate and positioned onto the product.	Contact between Pin 12 and Pin 14 (RUEL) is opened.
13	XETF 	Applicator fault This is an error message of the applicator. This message is shown when one of the following errors occurs at the applicator : <ul style="list-style-type: none"> - pad has not reached the labelling position within 2s after the movement of the cylinder - pad has not reached the starting position within 2s after the movement of the cylinder - a printed label has not been picked up by the pad properly or it fell down during the movement of the cylinder (message of the vacuum sensor) - the label is still on the vacuum plate of the pad when the cylinder moves back up (message of the vacuum sensor) The type of fault is shown in the display of the printer. After fault correction, the print of the last label printed before the fault occurred will not be repeated.	Contact between Pin 13 and Pin 14 (RUEL) is opened.
14	RUEL	Reverse line (for all output signals)	
15	24P 	Operating voltage +24V, Si T 100mA	

Table 3 PLC - connector pin assignment (continuance)

**Attention!**

Never apply any external voltage on Pin 15!

6.2 Circuit Diagrams Of Inputs And Outputs

The **inputs** are optical couplers with a current limiting resistor of 2.4kΩ in the input circuit. For each signal X[IN] there is a separate reverse line X[IN]R via the plug connector. From that, the following matching pairs of signals result :

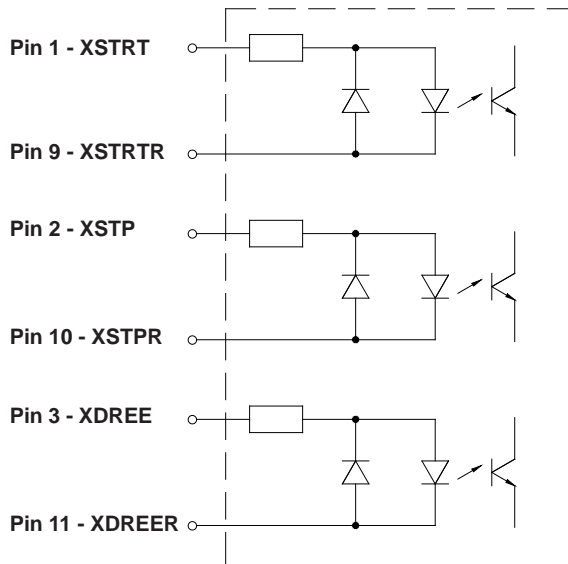

Figure 20 Circuit of the Inputs

All outputs are realized through solid state relays which outputs are connected among one another one-sided. The joint line is lead to the plug connector as RÜL signal. The switch function of the outputs is to open or close the contact between the joint line RÜL and the respective output.

Electrical requirements : $U_{max} = 42V$
 $I_{max} = 100mA$

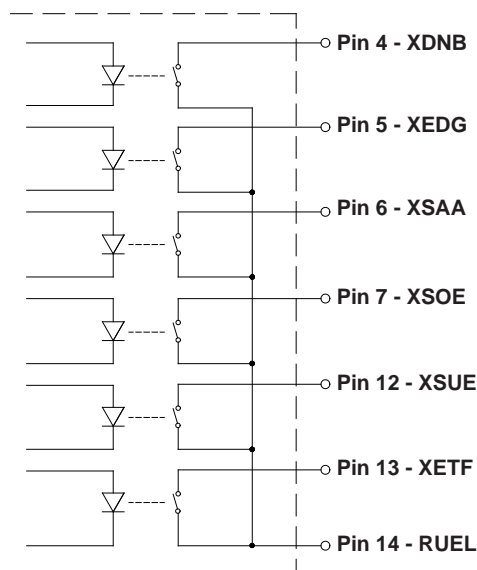

Figure 21 Circuits of the Outputs

6.3 Examples For Circuits To Creating An External Start Signal



Attention!
Should be exploit applicator data external, so it is to use an external voltage (24V) for signals. It's necessary that the external system and the printer/applicator system are electrically isolated.

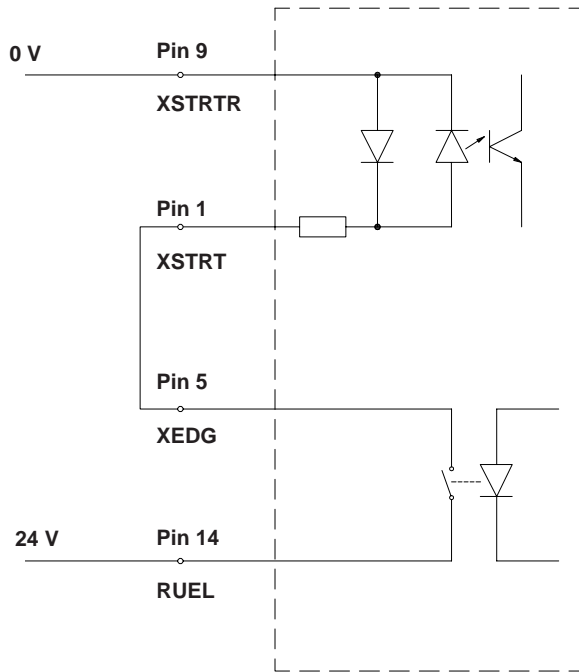

Figure 22 Example for start of the print- and labelling procedure for one label in case of an existing print job.

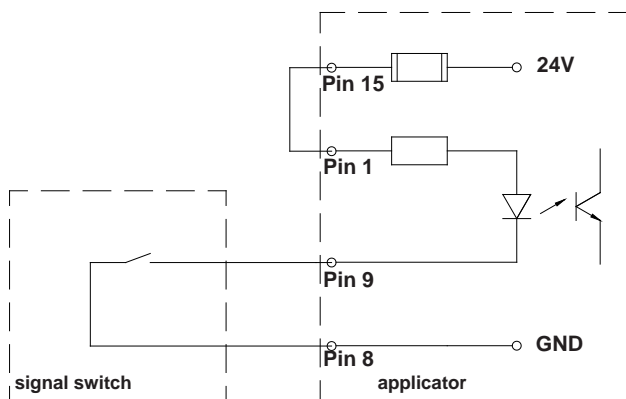

Figure 23 Example with releasing switch

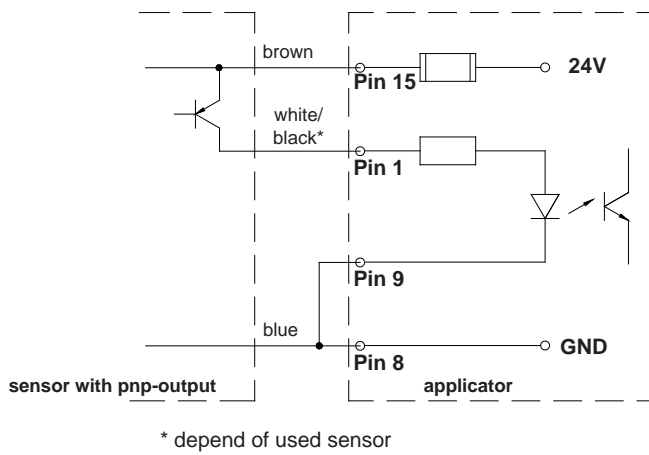

Figure 24 Example for an optical sensor with pnp-output

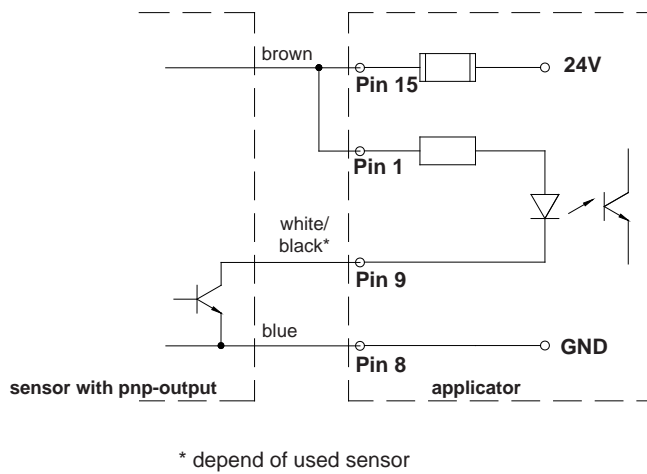

Figure 25 Example for an optical sensor with npn-output

7.1 Printer Error Messages

Detailed information about printer errors (e.g. 'Paper out', 'Ribbon out', etc.), their causes and correction methods can be found in the operator's manual for the printer



Notice!

With the installation of an applicator the error treatment expands. This means in particular, that after correcting the error and before the correction is quit with the key **[PAUSE]**, an additional label feed has to be released using the key **[FEED]**. This synchronizes the process of printing and labelling. Possibly dispensed blank labels have to be removed manually. After quitting the error message the label caused the error will be printed once more

7.2 Applicator Error Messages

The following table gives an overview of error messages and their possible cause. It also suggests methods to resolve the problem. After error correction, always quit the error message of the applicator with the key **[PAUSE]**. To reprint the label where the applicator error occurred, a new print job has to be released

Error message	Possible cause of error	Error handling
Label not deposit	Label has not been placed onto the product; after the lift cylinder has moved back the label still sticks on the vacuum plate of the pad	Manually labelling of the product
Upper position	Pad has not reached the starting position within 2s after the lift has moved back; or Pad has left the starting position unauthorized	Check the pneumatic adjustments (esp. the upper throttle valve of the cylinder); Manually labelling of the product
Host stop error	Labelling process has been interrupted by an XSTP stop signal via PLC interface	Manually labelling of the product if necessary
Reflex sensor faulty	There has been no change of the switch state at the upper control sensor (at the cylinder) between the start of the labelling process and the signal from the labelling position sensor	Check the sensors (service)
Vacuum plate empty	Label has not been picked up properly by the pad; or Label fell off the pad before it could be placed onto the product	If possible, place the 'lost' label onto the product manually; Otherwise stop print job and start again with adapted parameters (e.g. count)
Lower position	Pad has not reached the labelling position within 2s after the movement of the cylinder	Check the pneumatic adjustments (esp. the lower throttle valve of the cylinder); Make sure that the securing device has been unlocked; Check the applicator for heaviness of its mechanics; Check the labelling position sensor (service); Label the product manually

Table 4 Applicator error messages

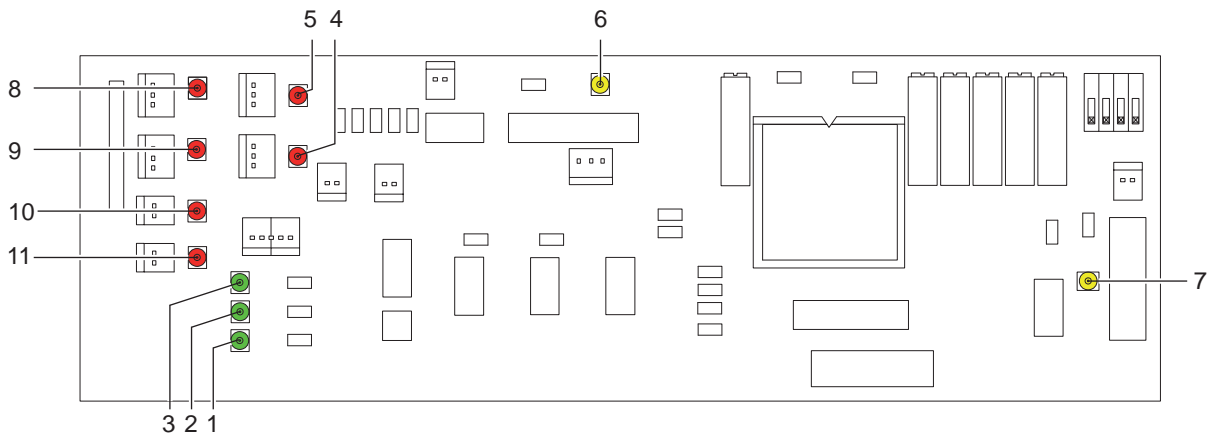

Figure 26 LED's on the PCB

LED-No.	Color	Function	Active state
1	green	PLC-signal XSTRT	ON
2	green	PLC-signal XSTP	ON
3	green	PLC-signal XDREE	ON
4	red	Upper position sensor	ON
5	red	Labeling position sensor	ON
6	yellow	Label on the pad	ON
7	yellow	Operating voltage 5V	ON
8	red	no function	-
9	red	no function	-
10	red	no function	-
11	red	no function	-

Table 5 LED's on the PCB

9.1 EC Declaration of Incorporation



Gesellschaft für Computer- und Automations-Bausteine mbH & Co KG
 Wilhelm-Schickard-Str. 14
 D-76131 Karlsruhe,
 Germany

EC Declaration of Incorporation

We declare herewith that the following „partly completed machinery“ as a result of design, construction and the version put in circulation complies with the essential requirements of the **Directive 2006/42/EC on machinery** :

Annex I, Article 1.1.2, 1.1.3, 1.1.5, 1.1.6, 1.2.1, 1.3.2, 1.5.2, 1.5.8, 1.6.3, 1.7

The „partly completed machinery“ additionally complies with the Directive 2004/108/EC relating to electromagnetic compatibility.

In the event of any alteration which has not been approved by us being made to any device as designated below, this statement shall thereby be made invalid.

Device:	Applicator
Type:	1005
Applied EC Regulations and Norms:	
Directive 2006/42/EC on machinery	• EN ISO 12100-1:2003
	• EN ISO 12100-2:2003
	• EN ISO 14121-1:2007
	• EN 60950-1:2006
Person authorised to compile the technical file :	Erwin Fascher Am Unterwege 18/20 99610 Sömmerda
Signed for, and on behalf of the Manufacturer :	Sömmerda, 25.01.2010
cab Produkttechnik Sömmerda Gesellschaft für Computer- und Automationsbausteine mbH 99610 Sömmerda	 Erwin Fascher Managing Director

The product must not be put into service until the final machinery into which it is to be incorporated has been declared in conformity with the provisions of the Directive on machinery

The documents according annex VII part B from the incomplete machinery are created and will commit to state agencies on request in electronic kinds.

Declaration of Conformity according Directive 2004/108/EC relating to electromagnetic compatibility on the next page

9.2 EC Declaration of Conformity



Gesellschaft für Computer-
und Automations-
Bausteine mbH & Co KG
Wilhelm-Schickard-Str. 14
D-76131 Karlsruhe,
Germany

EC Declaration of Conformity

We declare herewith that as a result of the manner in which the device designated below was designed, the type of construction and the devices which, as a result have been brought on to the general market comply with the relevant fundamental regulations of the EC Rules for Safety and Health. In the event of any alteration which has not been approved by us being made to any device as designated below, this statement shall thereby be made invalid.

Device:	Applicator
Type:	1005
Applied EC Regulations and Norms:	Applied Norms:
Directive 2004/108/EC relating to electromagnetic compatibility	<ul style="list-style-type: none"> • EN 55022:2006 • EN 55024:1998+A1:2001+A2:2003 • EN 61000-3-2:2006 • EN 61000-3-3:1995+A1:2001+A2:2005
Signed for, and on behalf of the Manufacturer :	Sömmerda, 25.01.2010
cab Produkttechnik Sömmerda Gesellschaft für Computer- und Automationsbausteine mbH 99610 Sömmerda	 Erwin Fascher Managing Director

Symbols

15 pin SUB-D connector..... 18

A

Adjustments..... 10

Air Tube 11

Attach Applicator At Printer.....8

B

Blow.....6

C

compressed air9

Conformity

EU Declaration of.....25

Connections.....9

Creating An External Start Signal.....21

Cylinder 13

D

Delay Times..... 14

Delivery.....8

DIP-Switches 14

E

Environment5

Error Messages23

EU Declaration of Conformity.....25

Examples For Circuits21

F

Function.....6

H

half cycle..... 16

I

Inputs And Outputs20

Installation8

Instructions4

Intended Use4

L

'Labelling / printing'

Operating mode 15

LED's On The PCB.....24

lever to unlock8

M

Mechanical 10

Mounting Applicator.....8

Mounting Pad9

N

Normal Operation 17

O

Operating Mode..... 14, 15

Operation.....14

Overview.....7

P

'Printing / Labelling'

Operating mode 15

Pad Position10

Pad Type9

Peel Position.....17

PLC Interface.....18

Pneumatic.....12

Potentiometer14

Pre-Dispense Key.....16

Product Description6

R

Read Settings Of Potentiometers 15

S

Safety Instructions4

Save values of potentiometers 14

Signals.....18

Stamp6

Stand by position14

Supporting air 12

T

Technical data.....6

Throttle valve cylinder..... 13

Throttle Valves At The Valve Block...12

Transport-locking.....8

V

Vacuum..... 12