

User manual

# OPTIMA 3



# WARNING

Do not expose the camera battery pack or other accessories to rain or humidity to prevent fire hazard or electric shock.

## For customers in the U.S.A.

### Tested To Comply With FCC Standards FOR HOME OR OFFICE USE

#### FCC Statement

This device complies with part 15 of the FCC Rules. Operation is subject to the following two conditions:

(1) This device may not cause harmful interference, and (2) this device must accept any interference received, including interference that may cause undesired operation.

## For customers in Europe



"CE" mark indicates that this product complies with the European requirements for safety, health, environment and customer protection. "CE" marked cameras are intended for sales in Europe.



This symbol [crossed-out wheeled bin WEEE Annex IV] indicates separate collection of electrical and electronic waste in the European countries. Please do not throw the equipment into the waste. Please recycle and dispose of properly.

## Declaration of Conformity

Model Name: OPTIMA 3

Trade Name: AgfaPhoto

Responsible Party:

plawa-feinwerktechnik GmbH & Co. KG

Address: Bleichereistrasse 18, 73066 Uhingen, Germany

Customer Care Hotline:

Germany: 0900 1000 042; 1,49€/ Min.

Europe: 00800 7529 2100

UK: +44 1908 488676,

Hong Kong: 852 3586 9168

Conforms to the following Standards:

EMC: EN 55022:1998/A1:2000/A2:2003 Class B

EN 55024:1998/A1:2001/A2:2003

EN 61000-3-2:2000/A1:2001

EN 61000-3-3:1995/A1:2001

following the provision of the EMC Directive (89/336/EEC, 2004/108/EEC)

# SAFETY PRECAUTIONS

## Camera notes:

- ❗ Do not store or use the camera in the following environments:
  - In the rain, and in humid or dusty environments.
  - In a place where the camera can be exposed directly to the sunlight or subject to high temperature, e.g. Inside a closed car in summer.
  - In a place where the camera is subject to a high magnetic field, e.g. near motors, transformers or magnets.
- ❗ Do not place the camera on a wet surface or places where dripping water or sand may come in contact with the camera.
- ❗ If the camera will not be used for a long period of time, remove the battery and the memory card from the camera and store them in dry environment.
- ❗ If you carry the camera suddenly from a cold location to a warm place, moisture may condense inside the camera. It is suggested that you wait for a while before turning on the camera.
- ❗ The warranty does not cover any type of data loss or corruption.

## Battery notes:

- ❗ Incorrect use of the batteries may cause them to leak, become hot, ignite or burst. Always observe the following precautions.

- Do not expose the batteries to water, and take particular care to keep the terminals dry.
- Do not heat the batteries or throw them into a fire.
- Do not attempt to deform, disassemble or modify the batteries.
- ❗ Keep the batteries out of reach of babies and small children.
- ❗ In cold locations, battery performance deteriorates and battery life is significantly shortened.

## Memory card notes:

- ❗ When using a new memory card, be sure to format the card with your digital camera before using it.
- ❗ Do not change or delete the folder names or file names in the memory card from your PC, the camera will not be able to display those edited files on the its LCD screen. To edit image data, copy the image data to the PC's hard disk first.
- ❗ The photos taken by this camera are stored in the auto-generated folder in SD card. Please do not store photos that are not taken by this model of camera, as this may make it impossible to recognize the picture when the camera is in playback mode.

# BEFORE YOU START

## Preface

Thank you for purchasing this AgfaPhoto digital camera. Please read this manual carefully and keep it in a safe place for future reference.

### Copyright

© Copyright 2010 plawa-feinwerktechnik GmbH & Co. KG All rights reserved.

No part of this publication may be reproduced, transmitted, transcribed, stored in a retrieval system, or translated into any language or computer language, in any form, by any means, without the prior written permission of plawa-feinwerktechnik GmbH & Co. KG.

### Trademarks

All trademarks mentioned in this manual are used for identification purposes only and are properties of their respective owners.

## Safety Information

Please read the following important information carefully before using the product.

- Do not take apart or attempt to service the camera yourself.
- Do not drop or knock the camera. Improper handling may damage the product.
- Turn off the camera before inserting or removing the battery and memory card.
- Use only the type of battery that comes with the camera. Using other types of batteries may damage the camera and void the warranty.
- Do not touch the camera lens.
- Please not expose the camera to harsh environments such as moisture, or extreme temperatures, which may shorten the life of your camera or damage the batteries.
- Do not operate or store the camera in dusty, dirty, or sandy environments.



- Do not expose the lens to direct sunlight for extended periods.
- Download all pictures and remove the batteries from the camera if you are going to store the camera for long periods of time.
- Do not use abrasive cleansers, alcohol-based, or solvent-based cleaners to clean the camera. To clean, wipe the camera with a slightly damp soft cloth.

## About This Manual

This manual provides you with instructions on how to use your AgfaPhoto digital camera. Every effort has been made to ensure that the contents of this manual are accurate, however plawa-feinwerktechnik GmbH & Co. KG reserves the right to make changes without notice.

### Symbols used in this manual

Throughout this manual, the following symbols are used to help you locate information quickly and easily:



Indicates the useful information to know.



Indicates precautions to be taken while operating the camera.

# CONTENTS

WARNING .....	i	Turning On and Off .....	13
SAFETY PRECAUTIONS .....	ii	Using the Mode Button .....	14
BEFORE YOU START .....	1	Setting Date/Time and Language .....	15
Preface .....	1	Setting the Date and Time .....	15
Copyright .....	1	Setting the Language .....	16
Trademarks .....	1	About the LCD Screen .....	17
Safety information .....	1	<b>BASIC OPERATION .....</b>	<b>18</b>
About this manual .....	2	Shooting in Auto Mode .....	18
Symbols used in this manual .....	2	Using the Zoom Function .....	18
<b>CONTENTS .....</b>	<b>3</b>	Basic Functions Menu .....	19
<b>GETTING READY .....</b>	<b>7</b>	Flash .....	19
Unpacking .....	7	Self-timer/Continuous Capture .....	20
Camera Views .....	8	Macro Mode .....	20
Charging the Battery .....	10	Exposure Compensation .....	20
Insert the Battery and SD/SDHC Card (Not included) .....	11	Advanced Functions Menu.....	21
		WB (White Balance) .....	22
		ISO .....	22

Quality .....	23	Manual Scene Mode (SCN) .....	32
Size .....	23	Sport .....	32
Color .....	24	Indoor .....	32
<b>USING THE MODES .....</b>	<b>25</b>	Snow .....	33
LCD Screen Display .....	25	Fireworks .....	33
Still Picture Mode Display .....	25	Museum .....	33
Video Shooting Mode Display .....	27	Night Landscape .....	33
Playback Mode Display .....	28	Children .....	33
Auto Scene Mode (ASCN) .....	29	Leaf .....	33
Landscape .....	29	Sunset .....	33
Portrait .....	29	Glass .....	33
Night Portrait .....	30	Landscape .....	33
Backlit Portrait .....	30	Night Portrait .....	33
Night Landscape .....	30	Face Detection .....	35
Macro .....	30	Smile Detection .....	36
Auto .....	30	Blink Detection .....	37
Panorama .....	30	<b>PLAYBACK .....</b>	<b>38</b>
		Viewing Photos and Videos .....	38

Thumbnail View .....	39	Continuous AF .....	50
Using Zoom on Playback (for still pictures only) 40		Expo Metering (Exposure Metering) .....	50
Using the Delete Button .....	41	Playback Menu .....	51
<b>USING THE MENUS .....</b>	<b>42</b>	Protect .....	51
Still Picture Menu .....	42	Delete .....	52
AF Mode (Auto-Focus mode) .....	43	DPOF (Digital Print Order Format) .....	53
AF-Assist Beam .....	43	Trim .....	54
Continuous AF .....	44	HDR-High Dynamic Range.....	54
Expo Metering (Exposure Metering) .....	44	Resize .....	55
Continuous Shot .....	45	Rotate .....	55
Date Imprint .....	46	Red-eye Reduction.....	56
Quick Review .....	46	Display Setup .....	56
Digital Zoom .....	47	Slideshow .....	57
Slow Shutter .....	47	Wallpaper Settings .....	57
Blink Detection .....	48	Menu Wallpaper .....	58
OIS Stabilization .....	48	Startup Screen.....	58
Movie Menu .....	49	Back To Default .....	59
		Setup Menu .....	60

Beep .....	61	APPENDICES .....	69
LCD Brightness .....	61	Specifications : OPTIMA 3 .....	69
Power Saver .....	62	Error Messages .....	73
Zone .....	62	Troubleshooting .....	75
Date/Time .....	63	Customer Care .....	76
Language .....	63		
File and Software .....	63		
Format Memory .....	63		
File Numbering .....	64		
Copy to Card (Copy internal memory to memory card) .....	64		
Reset Settings .....	65		
FW Version (Firmware version) .....	65		
Transmission .....	66		
Video System .....	66		
Connecting to a PC .....	67		
Setting the USB Mode .....	67		
Transferring Files to your PC .....	67		

# GETTING READY

## Unpacking

Your package should contain the camera model you purchased along with the following items. If anything is missing or appears to be damaged, please contact plawa-feinwerktechnik GmbH & Co. KG.



Warranty Card

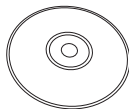

CD-ROM



Wrist Strap

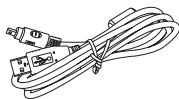

USB Cable

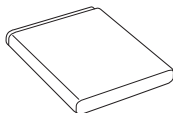

Rechargeable Lithium-ion battery

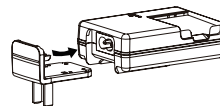

Battery charger

## Camera Views

Front View

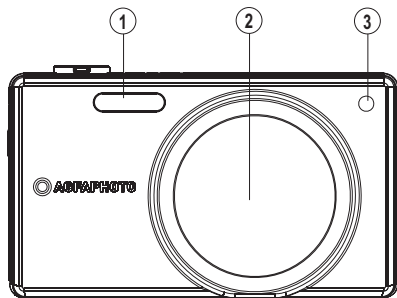

Back View

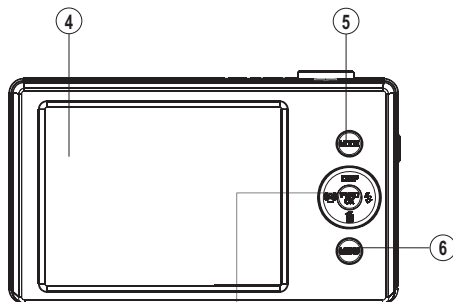

Right View

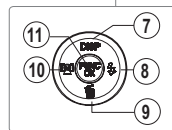

### Top View

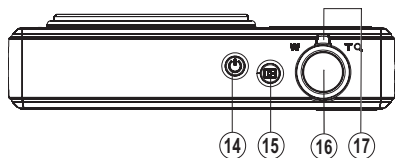

### Bottom View

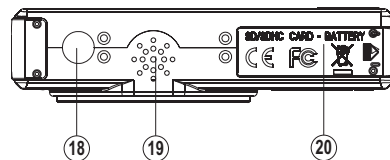

### Left View

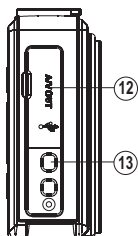



1	Flash	11	Function/OK Button
2	Lens	12	USB/AV Port
3	AF assist beam/Timer indicator	13	Wrist Strap Mount
4	LCD Screen	14	Power Button
5	Mode Selection Button	15	Playback Button
6	Menu Button	16	Shutter Button
7	Disp/Up Button	17	Zoom Wheel
8	Flash Mode/Right Button	18	Tripod Mount Point
9	Delete Button/Down Button	19	Speaker
10	Face Detection/Left button	20	Memory Card/Battery Compartment

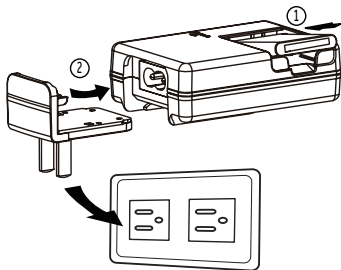

## Charging the Battery

1. Place the battery into the charger as shown.
2. Plug the one end of the connecting cable (plug adapter) into the charger base.
3. Plug the other end of the connecting cable into a wall outlet.



 Leave the battery to charge until the charger light turns green. (To maximize battery life, the first charge should be at least 4 hours)

 The charger is for indoor use only.

## Insert the Battery and SD/SDHC Card (Not included)

1. Open the battery compartment.

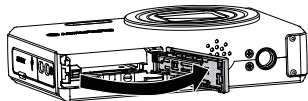

2. Insert the battery while observing the correct polarity. Use the side of battery to press down the stopper as shown, allowing the battery to lock into place properly.

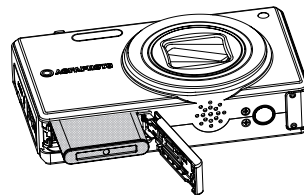
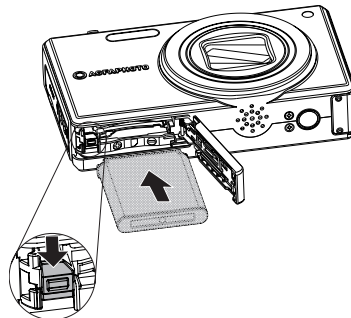

3. Insert an SD/SDHC card (not included) into the memory card slot as shown.

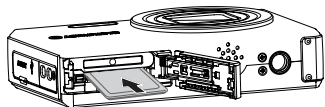
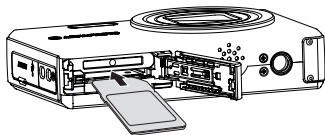

4. Close the battery compartment.

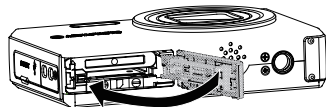

- Optional SD/SDHC cards are not included. The use of 64 MB to 16 GB memory cards from recognized manufacturers such as SanDisk, Panasonic and Toshiba is recommended for reliable data storage.
- To remove the SD/SDHC card, open the battery compartment and gently push the card to release it. Pull the card out carefully.

## Turning On and Off



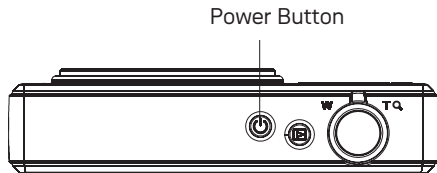



Press the Power button to turn the camera on. To turn off the camera, press the Power button again.



When the camera is turned on, it will be at the same shooting mode based on the last use. You can use the Mode button on the back to change modes. When using the camera for the first-time, the language setup page will appear. Please see page 15 or the Quick Start Guide in the package for details.

## Using the Mode Button

The AgfaPhoto camera provides a convenient mode Button that allows you to switch between different modes easily. After pressing the mode button to enter mode selection menu, press Left/Right button to choose the mode, press  $\text{func}$ / $\text{ok}$  to select. All the available modes are listed as follows:

Mode Name	Icon	Description
Auto mode		The camera sets all the settings automatically.
Manual mode		Switch to take still pictures in manual mode, where many camera settings can be configured. (Recommended for advanced users only)
Panorama mode		Switch to capture 4 shots and stitch them together into a panoramic photo.
Scene mode	SCN	Switch to take still pictures in 12 different scene types by your choice.
Movie mode		Switch to record videos.
ASCN mode		Switch to have the camera automatically select the best scene type for still pictures.
Portrait		Switch to take portrait pictures.

## Setting Date/Time and Language

### Setting the Date and Time

1. Press the menu button. Scroll over to the General Setup menu indicated by a wrench icon. Use the **Up/Down** button to select **Date/Time**. Then press the **Right** button to enter the setting.
2. Press the **Left/Right** to highlight each field and use the **Up/Down** to adjust the value.
3. Press the **func ok** button to confirm the setting.

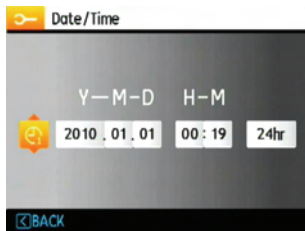
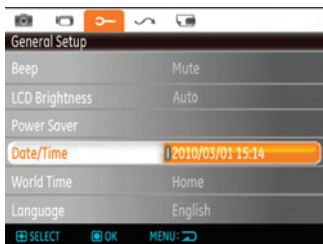

## Setting the Language

1. Press the menu button. Scroll over to the General Setup menu indicated by a wrench icon. Use the **Up/Down button** to go to the **Language**. Then press the **Right button** to enter the setting.
2. Use the Left/Right buttons to select the desired language.
3. Press the  $\text{func}_{\text{ok}}$  button to confirm the setting.



The Date/Time and Language setup will automatically appear when the camera is turned on the first time.



## About the LCD Screen

When you turn the camera on, various icons are shown on the LCD screen to indicate the current camera settings and status. To learn more about the displayed icons, see “**LCD Screen display**” on page 25.

### LCD Screen notes:

Extremely high-precision technology has been used to manufacture the LCD screen so that most of the pixels are operational for use. However, there may be some minute points (black, white, red, blue or green) that constantly appear on the LCD screen. These points are normal in the manufacturing process and the recording is not affected in any way.



Avoid exposing the LCD screen to water; please remove any moisture on the LCD screen with a soft dry cleaning cloth.



If the LCD monitor is damaged, take particular care with the liquid crystal in the monitor. If any of the following situations arise, take the recommended immediate action indicated below:

- If liquid crystal comes in contact with your skin, wipe the area with a cloth and then wash thoroughly with soap and running water.
- If liquid crystal gets into your eye, flush the affected eye with clean water for at least 15 minutes and then seek medical assistance.
- If liquid crystal is swallowed, flush your mouth thoroughly with water. Drink large quantities of water and induce vomiting. Then seek medical assistance immediately.



# BASIC OPERATION

## Shooting in Auto Mode

**Auto** mode is the easiest mode to take photos. While operating in this mode, the camera automatically optimizes your photos for best results.

To start shooting, do the following:

1. Press **Power** to turn the camera on.
2. In the Mode menu, select the Auto mode (  ).
3. Compose your picture on the LCD screen and press the Shutter button halfway to focus on the subject.
4. The focus frame in the middle of the LCD will turn to green when the subject is properly in focus.
5. Press **Shutter** fully to capture the image.

## Using the Zoom Function

Your camera is equipped with two types of zoom: optical zoom and digital zoom. Use zoom control at the top of the camera to zoom in or out on your subject while taking pictures.

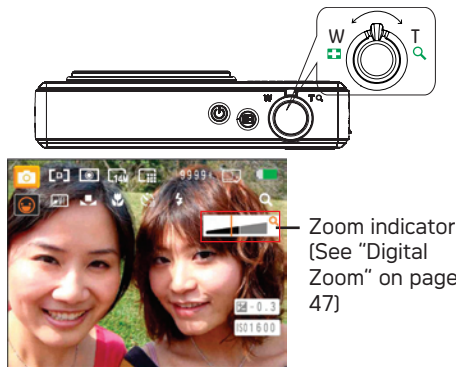

When the optical factor reaches its maximum value, it stops momentarily. Release and push the zoom wheel again, and the optical zoom will switch over to digital zoom automatically. After the adjustment, the zoom indication scale hides immediately, and the current zoom status is indicated by the following symbol  .

## Basic Functions Menu

The Basic Function Menus of the camera include Flash, Self-timer, Macro Capture, and Exposure Compensation.

Set the basic functions as per the following steps:

1. Pull up the Basic Function Menu by pressing Right/Flash button.





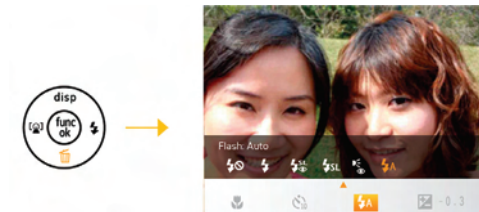



2. Press Left/Right button to select the settings of the required function.
3. Press **func**/**ok** button to confirm the settings and exit the menu, or press Down button to enter the selection screen of Basic Function.





4. Press Left/Right button to select the basic functions required to set, press Up button to enter the setting screen for selecting basic functions, or press **func**/**ok** button to confirm the settings and exit the screen.

### Flash

-  **Flash: Auto**  
Camera flash fires if camera determines it is needed.
-  **Flash: Red-eye reduction**  
Red eye is caused by the subject looking directly at the flash and the resulting light reflecting off of the retina of the eye. Red eye is eliminated by firing a smaller initial flash prior to the main flash to cause the subject not to look directly at the flash.



-  Flash: Forced flash  
Flash always fires.
-  Flash: Forced off  
Flash is turned off.
-  Flash: Slow Synchro  
This allows you to take pictures of people at night that clearly show the subject. The shutter is held open longer to allow more light to the image sensor.
-  Flash: Red-Eye+Slow Synchro  
Using this mode for slow synchro shots with red-eye reduction.

### Self-timer/Continuous Capture

-  Self-timer: 2 sec  
A single picture is shot 2 seconds after the Shutter button is pressed.
-  Self-timer: 10 sec  
A single picture is shot 10 seconds after the Shutter button is pressed.
-  Self-timer: Unlimited  
Pictures are shot continuously when the Shutter button is pressed down based on the Continuous Shot settings in the menu. (See "Continuous Shot" on page 45).

-  Self-timer: Off  
Disables the self-timer.

### Macro Mode

-  Macro: On  
Select this to focus on subjects 5cm from the lens.
-  Macro: Off  
Select this option to disable Macro.

### Exposure Compensation

The exposure compensation allows you to adjust the light exposure value and shoot the best photo.



The adjustable range of exposure value is from EV -2.0 to EV+2.0.

## Advanced Functions Menu

The Advanced Functions Menu of the camera include Image Size, Image Quality, White Balance, Image Color and ISO.

Set the advanced functions as follows.

1. Pull up the Advanced Function Menu by pressing **func ok** button.



2. Press Left/Right button to select the settings of the required function.
3. Press **func ok** button to confirm the settings and exit the menu, or press Down button to enter the selection screen of Advanced Functions.









4. Press Left/Right button to select the advanced functions required to set, press Up button to enter the setting screen for selecting advanced functions, or press **func ok** button to confirm the settings and exit the screen

## WB (White Balance)

The White Balance allows you to adjust the color temperature under different lighting conditions. (The WB setting is only available when the camera is in the **M Manual** mode).



The options of White Balance include:

-  WB: Auto
-  WB: Daylight
-  WB: Cloudy
-  WB: Fluorescent
-  WB: Fluorescent CWF
-  WB: Incandescent
-  WB: Manual (Press the shutter button to set WB.)

## ISO

The ISO function allows you to set the sensitivity of the camera sensor to light. To improve the performance in darker environments, a higher ISO value is required. On the other hand, a lower ISO value is needed when in bright conditions. (The ISO setting is only available when the camera is in the **M Manual** mode).

Pictures at higher ISO will naturally have more noise than those at lower ISO.



The options of ISO include automatic, 80, 100, 200, 400, 800, 1600 and 3200.



The available ISO values vary on different camera models.

## Quality

The quality setting determines how much the camera compresses the photo files. The higher the compression, the smaller the file size will be, but the quality will decrease. The lower the compression, the larger the file size, but the better the quality.



The three levels of compression are:

-  : Quality: Best
-  : Quality: Fine
-  : Quality: Normal

## Size

The size setting refers to the image resolution in pixels. A higher image resolution allows you to print that image in larger sizes without degrading the image quality.







-  The larger the pictures are, the bigger the file sizes are and the less pictures you can store on a memory card.

## Color

The color setting allows you to add artistic effects directly when taking pictures. You can try different color tones to alter the mood of your pictures. (The Color setting is only available when the camera is in the **M** **Manual** mode).



The color options include:

-  Color: Auto
-  Color: Vivid
-  Color: Black & White
-  Color: Sepia

# USING THE MODES

## LCD Screen Display

### Still Picture Mode Display

Mode:    SCN  

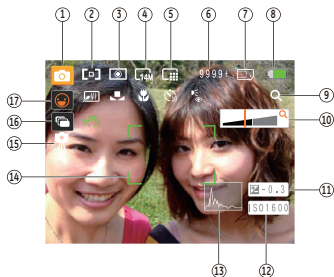



### 1 Shooting Mode Icons

- |   |   |
|---|---|
|  Auto mode     |  Manual mode |
|  ASCN mode     |  Scene mode  |
|  Panorama mode |  Portrait    |

### 2 AF Mode

-  Single-AF
-  Multi-AF

### 3 Expo Metering

-  Spot
-  Center
-  AiAE

### 4 Image Size

### 5 Image Quality



6 Remaining number of pictures

7 Memory card/built-in memory

8 Battery Status

9 WT Ratio (Displayed only when zoom is activated)

10 Zoom

11 Exposure

12 ISO Value (Adjustable only in  Manual Mode)

13 Histogram

14 Focus Frame

15 Slow Shutter Warning

16 Continuous Shot

17 Face Detection

18 OIS

 Continuous ON

 In shooting

19 Picture Color (Adjustable only in  Manual Mode)

20 White Balance (Adjustable only in  Manual Mode)

21 Macro Mode

22 Self-timer

 Self-timer: 2 sec

 Self-timer: 10 sec

23 Flash Mode

 Flash: Auto

 Flash: Red-eye reduction

 Flash: Forced flash

 Flash: Forced off



 Flash: Slow Synchro

 Flash: Red-Eye+Slow Synchro

## Video Shooting Mode Display

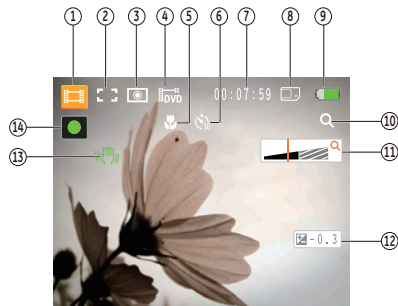
Mode : 



- 1 Video Mode icon
- 2 Continuous AF
- 3 Metering
  -  Spot
  -  Center
  -  AiAE
- 4 Image Size
- 5 Macro mode

- 6 Self-timer

 Self-timer: 2 sec

 Self-timer: 10 sec

- 7 Remaining Time for Video Recording

- 8 Memory Card/Built-in Memory

- 9 Battery Status

- 10 WT Ratio (Displayed only when zoom is activated)

- 11 Zoom

- 12 Exposure

- 13 OIS

 Continuous ON

 In shooting

- 14 Recording Status Icon

 Recording standby

 Recording

 In order to shoot video, it is recommended that an SD card be used.

 When shooting video, the optical zoom is disabled.

## Playback Mode Display

Mode: 

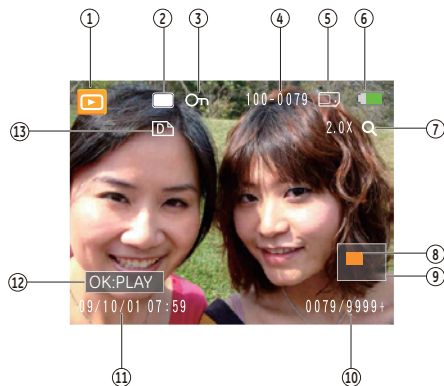

1. Play Mode icon
2. Picture File
3. File protection
4. Picture Number
5. Memory Card/Built-in Memory
6. Battery Status
7. Image Zoom
8. The current display area
9. Zoom area shown
10. Memory Space (this picture/Total number of pictures)
11. Recording Date and Time
12. OK:PLAY
13. DPOF file

## Auto Scene Mode (ASCN)

In the "**ASCN**" mode, different conditions are detected intelligently and the most suitable settings will be automatically selected.

To use "ASCN":

1. Press Mode Selection button to select ASCN mode, LCD screen will be shown as follows.



2. Hold the camera steadily and aim at the subject. The optimum scene mode will be identified automatically.
3. Press the Shutter button halfway down to focus.
4. Press the Shutter button all the way down to take the picture.

Icon	Mode name	Icon	Mode name
	Landscape Mode		Night Landscape Mode
	Portrait Mode		Macro Mode
	Night Portrait		Auto Mode
	Backlit Portrait		

### Landscape Mode

For landscapes, ASCN will automatically adjust the exposure to match the background.

### Portrait Mode

For portraits, ASCN will automatically adjust the exposure and skin tones to give clear pictures.

## Night Portrait

When you shoot portraits at night, or in low light conditions, ASCN will automatically adjust the exposure for people and night scenes.

## Backlit Portrait

When the sun or any other light source is behind you, ASCN will automatically adjust the foreground exposure to produce good pictures.

## Night Landscape Mode

For night scenes, ASCN will automatically increase the ISO value to compensate for low light.

## Macro Mode

To capture object detail for close-ups, ASCN will automatically adjust the focus.

## Auto Mode

The camera automatically adjusts the exposure and focus to ensure good pictures.



## Panorama

Panorama Mode allows you to create a panoramic picture by stitching together several pictures.

Follow these steps to create a panoramic picture:

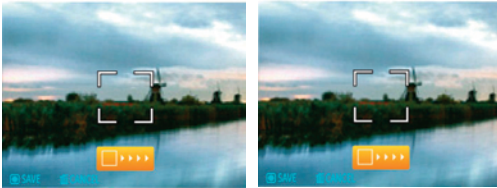
1. Press Mode Selection button to select Panorama Synthesis mode 
2. Use the **Left/Right** buttons to specify the direction of picture taking, if no choice is made in 2 seconds the panoramic sequence will commence automatically.
3. Compose the first view of the panoramic picture on the LCD screen and press the Shutter button to capture.
4. After the first shot is taken, two target icons will appear on the left and right side of the LCD screen. Pan the camera in the specified direction and the circle will move towards the square frame icon. When the circle icon and square frame overlap they will become green and the camera will capture the next picture automatically.



5. The camera will then stitch the pictures automatically.
  6. Press the playback button to enter Playback mode and review the result.
-  Pictures cannot be deleted, nor the zoom adjusted until the series is finalized.
  -  2~4 images can be stitch together.

## Manual Scene Mode (SCN)

In **Manual Scene** mode, you can select from a total of 12 scene types to match your needs. You just need to select the right scene for the occasion and the camera will automatically adjust to the optimal settings for you.

Press the **mode** button, select "SCN" with the Left/Right button, and the LCD screen will show the figures as below.

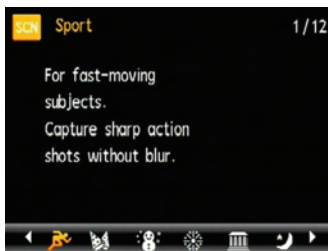

Select a scene using the Left/Right button and press the **func<sub>ok</sub>** button.

Icon	Mode Name	Icon	Mode Name
	Sport		Indoor
	Snow		Fireworks
	Museum		Night Landscape
	Children		Leaf
	Sunset		Glass
	Landscape		Night Portrait

### Sport

For fast-moving subjects. Capture sharp action shots without blur.

### Indoor

For indoors. Reduce blur and improve color accuracy.

### **Snow**

For snow scenes. Reproduce natural and clear white scenes.

### **Fireworks**

For fireworks at night. Slow shutter speed adjusted for brilliant images.

### **Museum**

For museum or flash-free area. Retain color and reduce blur.

### **Night Landscape**

For night scenes. Use of tripod is recommended.

### **Children**

For kids and pets. Flash is disabled for eye protection.

### **Leaf**

For plants. Capture brilliant shots of greenery and blossoms.

### **Sunset**

For sunsets. Capture subjects in strong sunlight.

### **Glass**

For objects behind transparent glass.

### **Landscape**

For landscapes. Vivid reproduction of green and blue.

### **Night Portrait**

For portraits against night time scenery.





1. After selecting the scene type, press the **func**  
**ok** button to select.
2. To select a different scene type, press the **func**  
**ok** button to enter the main function menu. Then  
press it again to return to the Scene selection  
menu.

The main function menu also allows you to adjust the image quality and image size. Please refer to the "**Advanced Functions Menu**" section on page 21 for detailed instructions.

## Face Detection

The Face Detection mode will detect and enhance facial features.

1. In Shooting mode, press the Left/Face Detection button to turn on the Face Detection and an icon (  ) appears on the LCD.
2. Hold the camera securely, and point the camera towards the subject to start the face detection process. When the camera detects a face, a white rectangular frame will be drawn around the face. (Note: For best results, the face of the subject should be relatively large on the LCD screen, and the subject should be facing the camera as front on as possible.)
3. Press **Shutter** halfway to focus on the subject.
4. Press **Shutter** fully to capture the image.
5. Press the Left/Face Detection button to turn off Face Detection.

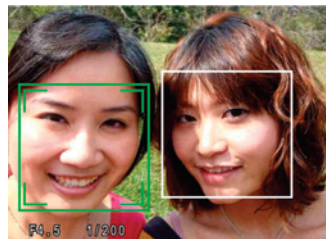
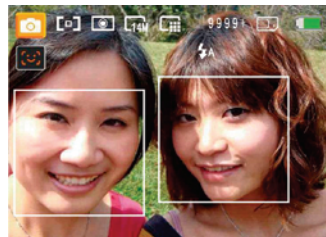

## Smile Detection

With the "Smile Detection" feature, the camera automatically detects and captures a person smiling.

1. In Shooting mode, press the Left/Face Detection button to turn on Smile Detection and an icon (  ) appears on the LCD.
2. Point the camera at the subject until the subject's face is detected and bracketed by a square box. Press the Shutter button all the way down and release the Shutter button. The camera will now 'wait' for the subject to smile.
3. When the subject smiles, the camera will automatically release the shutter and capture the photo.
4. To disable Smile Detection function, please press Left or Shutter button.



A face must be detected by the camera in order for smile detection to function correctly.



For optimal detection results, the subject should be framed to occupy most of the screen space.

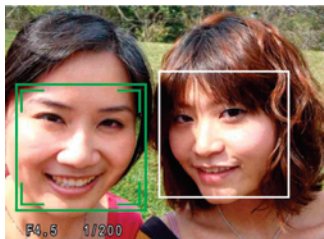
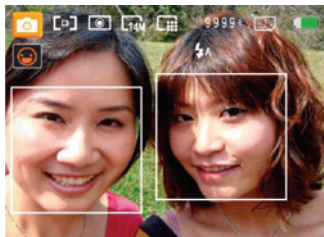

## Blink Detection

The Blink Detection feature is on by default, and after taking each photo, a warning message will pop up if a blink has been detected in the photo.

1. In any Still Shooting modes, press the **menu** button to enter the photo menu.
2. Switch between different Photo Setup menus and Camera Setup menus using the Left/Right button, and select the "Blink Detection" setting using the Up/Down button.
3. Use the Right navigation buttons to enter the submenu, and select "On" option.
4. Press the **func**/**ok** button to confirm the setting and exit the menu.
5. Press the Shutter button fully to capture the image. A warning message will be shown on the LCD immediately after detecting someone has blinked in the picture.

 A face must be detected by the camera in order for smile detection to function correctly.

 For optimal detection results, the subject should be framed to occupy most of the screen space.



# PLAYBACK

## Viewing Photos and Videos

To view the captured photos and video clips on the LCD screen:

1. Press  button to go to the **Playback** mode. The last recorded photo or video clip is displayed.
2. Use the **Left/Right** navigation buttons to scroll through the photos or video clips stored in the internal memory or memory card.
3. To play a selected video clip, press the **func ok** button to enter the movie playback mode.

During video playback, the operating instructions will appear on the screen. Press the Left/Right button, and press the **func ok** button for confirmation.

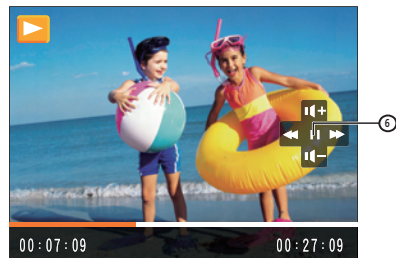
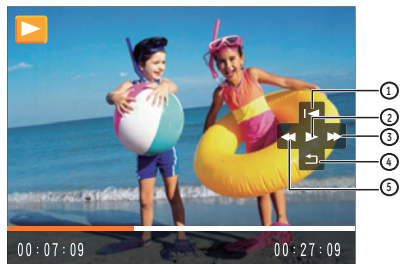

The operating instruction icons are as follows.

- |   |              |   |        |
|---|--------------|---|--------|
| 1 | First Frame  | 4 | Back   |
| 2 | Play         | 5 | Rewind |
| 3 | Fast Forward | 6 | Pause  |

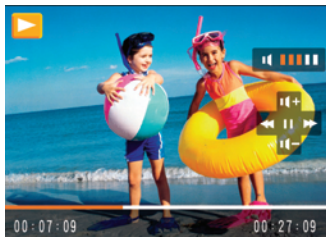

During video playback, you can press the Up/Down button to adjust the volume.



## Thumbnail View

In Playback mode, turn the zoom control to display thumbnails of pictures and video clips on the LCD screen.



1. Display thumbnail with 2x2, 3x3 and 4x4 by switching the Zoom lever.
2. Use **Up/Down/Left/Right** to select a photo or video clip to view.

 If the  indicator appears on the LCD, then a movie file is currently being displayed.

 Press the **func**/**ok** button to restore a preview icon to its original image size.

## Using Zoom Playback (for still pictures only)

When playing photo, you can also use zoom lever to zoom in it (2~8) times.

1. Press  button to go to the **Playback** mode.
2. Use the **Left/Right** navigation buttons to select a photo to magnify.
3. Adjust the Zoom lever to the side  to zoom in the photo.
4. Use the Zoom Wheel to enlarge the image. The zoom indication area will be shown by the icons in the lower right corner of the display screen.

5. Use the navigation buttons to pan across the image.
6. Press the  button to return the image to its original scale.



Movie images cannot be magnified.



## Using the Delete Button

In Playback mode, you can press the Down/Delete button to delete pictures or videos.

To delete pictures or videos:

1. Press  button to go to the Playback mode.
2. Select a picture or video clip you want to delete with the Left/Right button.
3. Press the Down/Delete button and the delete screen appears.
4. Select Yes or Back with Up/Down button and press the <sup>func</sup><sub>ok</sub> button for confirmation.



Erased photos/video clips cannot be recovered.



Please refer to page 52 for instructions on the Delete Menu options.





# USING THE MENUS

## Still Picture Menu

Mode:    SCN 

In any of the above Still Picture Modes, press the **menu** button to go to the Still Picture menu.

To adjust each setting:

1. In the Still Picture menu, switch between different Photo Setup or Camera Setup pages using the Left/Right button, to select the page with the function you want to adjust and press the Down button.

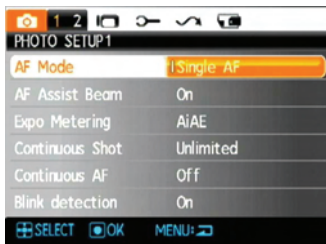

2. Press the Up/Down buttons to select the function.

3. Press the Right button to go to the submenu.

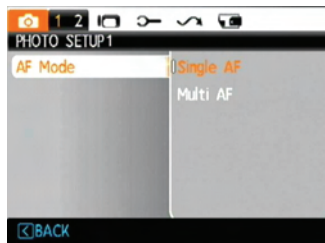

4. Press Up/Down button to select an option or press the Left or **menu** button to return to the menu.
5. Press the **func** button for confirmation and exit the menu.



After selecting a function, you can press the Up button to return to the Still Picture menu for other Photo Setup or Camera Setup pages. Or you can press the Down button several times to move to the next setup menu page.

Refer to the following pages for more details about each setting.

## AF Mode (Auto-Focus mode)

Use this setting to control the auto-focus mechanism while taking pictures.



Two options are available:

- **Single AF:** The focus frame appears on the center of the LCD screen to focus on the subject.
- **Multi AF:** The camera uses multiple parts of the picture to correctly focus.

## AF Assist Beam

This option can turn on or turn off AF assist lamp. The AF assist lamp assists the camera in focusing correctly in low light conditions. It is not recommended that this be turned off or the camera may not focus correctly.

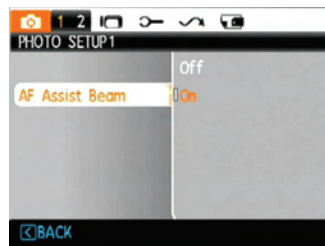

## Continuous AF

The camera continuously focuses as the subject moves such as a sports player.



## Expo Metering (Exposure Metering)

This setting determines what part of the picture the camera uses to determine the correct exposure for the whole picture.



Three options are available:

- **Spot**
- **Center**
- **AI AE** (Artificial Intelligence AE)

## Continuous Shot

Use this setting to perform continuous shooting. Once in this mode, you must continuously hold down the Shutter button to take multiple frames.

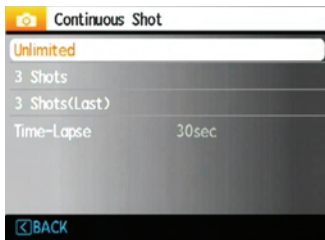

Four options are available:

- **Continuous shooting:** Press and hold the shutter to shoot continuously until you release the shutter or when the memory card has run out of space.
- **3 shot:** Capture up to 3 consecutive pictures.
- **3 shots (Last):** Capture pictures continuously until the Shutter button is released but only the last 3 shots are recorded.
- **Time-Lapse:** Automatically capture pictures in a predefined interval.

- ① The flash is designed not to work in this mode in order to enable quick succession of shots.
- ① Continuous Shot can only be selected in Self-timer Mode.

## Date Imprint

Include a Date/Time stamp in the photo image.

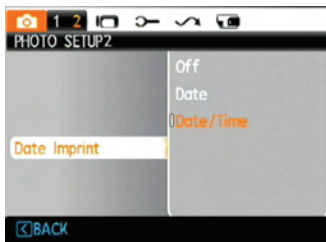

- Off
- Date
- Date and Time

## Quick Review

This setting refers to the quick photo review immediately after taking a picture. The picture stays on the LCD screen for an adjustable period of time.

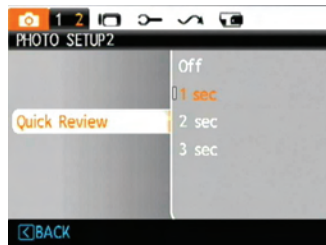

Four options are available:

- Off
- 1 sec
- 2 sec
- 3 sec

## Digital Zoom

Use this setting to enable or disable the digital zoom function. When disabled, only the optical zoom is enabled.

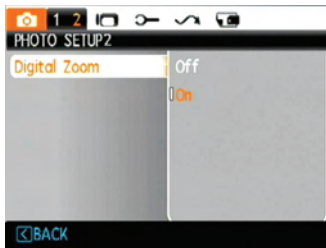

## Slow Shutter

In Slow shutter mode, the shutter will remain open as long as the Shutter button is pressed. This gives you complete control over the duration of exposure. (The slow shutter mode is available only in **M** manual mode.)

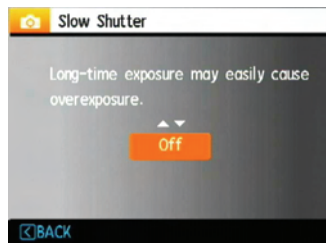

- **Manual** : To set a long exposure time between 2~30 sec.



The use of tripod is recommended for prolonged exposure.

## Blink Detection

The Blink Detection feature is on by default, and after taking each photo, a warning message will pop up if a blink was detected in the photo.

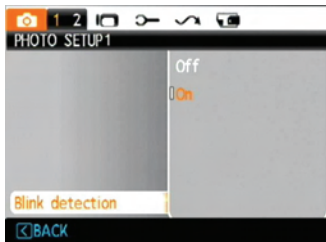

- Off
- On

## OIS Stabilization

Turning on the OIS Stabilization will avoid blurred images caused by hand shake and deliver sharper photos. [This function is not available in panorama mode.]

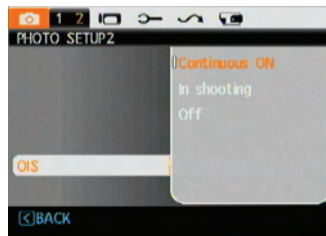

- Continuous ON
- In shooting
- Off



Shooting in a windy or unstable environment (such as moving vehicle) may cause blurred images.

## Movie Menu

Mode: 

In the Movie Mode, press the **menu** button to go to the corresponding Movie menu.

To configure each setting:

1. In the Movie menu, switch between the Movie Setup or different Camera Setup pages using the Left/Right button, select the page with the function you want to adjust and press the Down button.

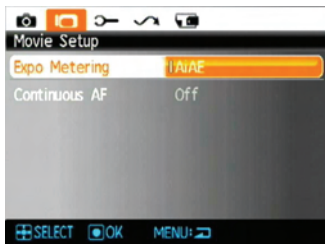

2. Press the Up/Down button to select the function and press the Right button to go to the

submenu.

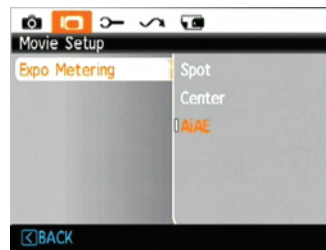

3. Press the Up/Down button to select an option or the Left or **menu** button to return to the menu.
4. Press the **func ok** button for confirmation and exit the menu.

Refer to the following pages for more details about each setting.



## Continuous AF

The camera continuously focuses as the subject moves such as a sports player.



## Expo Metering (Exposure Metering)

This setting determines what part of the picture the camera uses to determine the correct exposure for the whole picture.

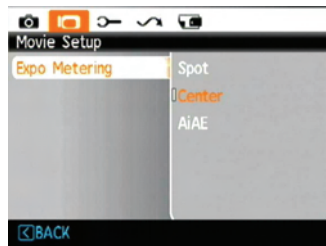

Three options are available:

- **Spot**
- **Center**
- **AiAE** (Artificial Intelligence AE)

## Playback Menu

Mode : 

In Playback mode, press the **menu** button to enter the **Playback** menu.

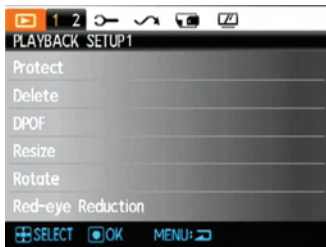

Please refer to the following sections for detailed instructions on the various menu options.

### Protect

To prevent any pictures or videos from being accidentally erased, use this setting to lock one or all of the files.

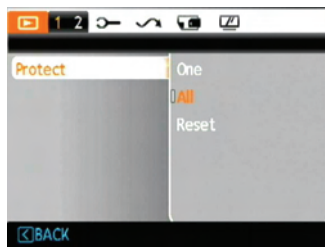

To protect/unprotect a picture or video:

1. Press  button and find the picture or video you want to protect by using Left/Right button. Once it is displayed on the screen, go to the Playback menu and select Protect settings.
2. Use the **Up/Down** navigation buttons to select **One** to protect this picture/video, or select **All** to protect all pictures/videos in the internal memory or memory card. Then press the **Right** navigation button to enter the submenu.

3. Press the **func**/**ok** button to select Yes to lock. For locked picture/video, use Unlock option to unlock it.
4. A key (  ) icon will appear on the top of the screen to indicate that the picture/video is protected. Select Back with Up/Down navigation buttons to return into the Playback menu.
5. Select **Reset** on the Protection setting to remove protection for all files that have been placed in the protected mode.

## Delete

There are two ways to delete files.

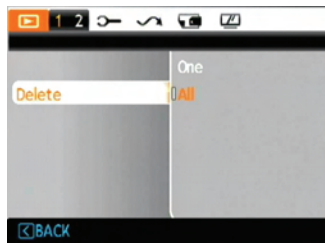

### • Delete One:

1. On the Delete setting, select One and press the Right button.
2. Using the **Left/Right** buttons, locate the photo or movie file to be deleted. Select **Yes** (to delete file) or **No** (to return to the previous menu) using the **Up/Down** buttons, then press the **func**/**ok** button to confirm.

### • Delete All:

1. On the Delete setting, select **All** and then press the **Right** button.
2. Using the **Up/Down** buttons, select **Yes** (to delete all files) or **No** (to cancel and return to the previous menu).



The “” indicator means a file is protected. File protection must be removed first before a file can be deleted.



Deleting files will cause DPOF settings to be reset.

### DPOF (Digital Print Order Format)

DPOF allows you to record your selection of pictures that you would like to print, and will save your selection in the memory card, so that you can simply hand your memory card to a photo kiosk without having to tell them in person which photos you would like to print.

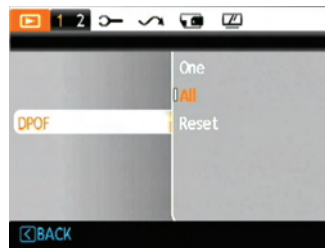

## Trim

The Trim setting allows you select an area of the photo you want to keep and then save it as a new photo.

To trim a picture:

1. Select the **Trim** setting from the  menu.
2. Using the **Left/Right** buttons, locate the photo that you want to crop and have it displayed on the LCD, that you need to press "YES" if the image is chosen.
3. Use the zoom buttons and navigation buttons to adjust the trimming box to fit the location and size of the new picture.



4. "Save Changes?" prompt will display after pressing  button, select "O" to confirm the changes and save the image, or select "X" to cancel the changes and return to the screen of trim prompt.



The image can not be cropped again when it is cropped to 640X480.

## HDR-High Dynamic Range

With the HDR function, pictures that may be overexposed may be corrected to optimize the highlights and lowlights captured to more accurately represent the real scene.

1. Select HDR setting in  menu as described previously.
2. Press Left and Right button to find picture you want to optimize and then select Yes to perform HDR optimization or select Return to go back to Playback menu.



3. After using HDR function, the image will be saved as a new file, and the original file is still stored in the memory.

## Resize

This setting allows you to resize a picture to a specified resolution, and saves it as a new picture.

1. Select the **Resize** setting from the **Playback** menu as described previously.



2. Use the **Left/Right** navigation buttons to select a picture to resize.
3. Use the **Up/Down** navigation buttons to select a resolution (**1024X768** or **640X480**) to resize the image or **Back** to cancel and return to the **Playback** menu.
4. Press the **func**/**ok** button to confirm the setting.



Resizing an image creates a new file that contains the image in the size you select. The file with the original image also remains in memory.

## Rotate

You can use this setting to change the picture orientation of the picture.

1. Select the **Rotate** setting from the **Playback** menu as described previously.
2. Use the **Left/Right** navigation buttons to select a picture to rotate.
3. Use the **Up/Down** navigation buttons to select the direction for rotation or **Back** to cancel and return to the **Playback** menu.

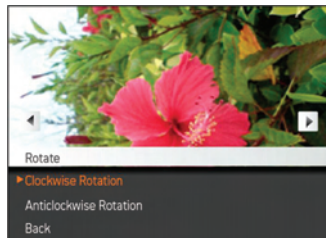

4. Press the **func**/**ok** button to confirm the setting.

## Red-eye Reduction

Use this setting to remove red eye in your photos.

1. Select the **Red-eye Reduction** in **Playback** menu as described previously.
2. Use the **Left/Right** button to select the picture from which the red eye needs to be removed.
3. Use the **Up/Down** navigation buttons to select **Yes** to fix the selected image or **Back** to cancel and return to the **Playback** menu.

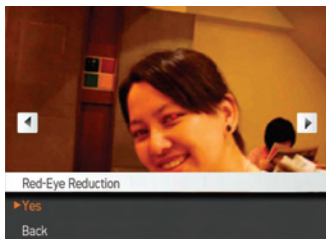

4. Press the **func**/**ok** button to confirm the setting.



For best results, the face of the subject should be relatively large on the LCD screen, the subject should be facing the camera as front on as possible, and the red eyes should be as large as possible.

## Display Setup

**Mode:** 

Press **menu** button in Playback mode to enter Display Setup menu.

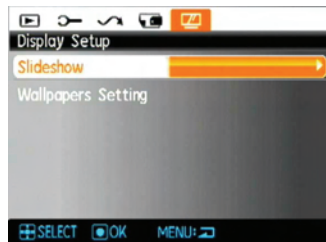

Refer to the following sections for details of every setting.

## Slideshow

This setting allows you to view all the stored pictures as a slideshow.

1. Select the slideshow menu, press the right button to enter the options menu.
2. Use the **Up/Down** navigation buttons to select Effect, Interval time, or Repeat and use the **Left / Right** navigation buttons to adjust the setting.

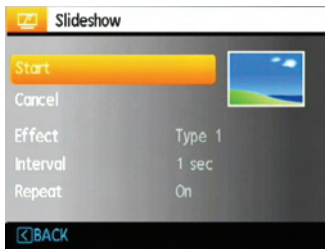

3. Use the **Up/Down** navigation buttons to select **Start** to run the slideshow or **Cancel** to return to the **Playback** menu.
4. Press the **func ok** button to confirm the setting.

## Wallpaper Settings

Use this setting to select your favorite picture to use as a background on the LCD screen.

1. Press Down button to select the Wallpaper Setting menu.

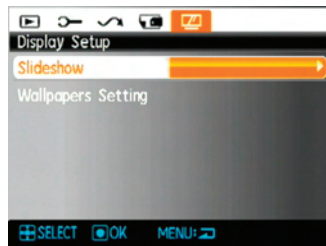

2. Press Right button, and the camera will enter the Wallpaper Setting interface.





## Menu Wallpaper

Use Up/Down button to select the Menu Wallpaper option, press **func**/**ok** button to confirm or press Left button to return to last page, and press **menu** to exit the menu.



- User
- AgfaPhoto
- Sparkling

## Startup Screen

Use Up/Down button to select the Startup Screen option, press **func**/**ok** to confirm or press Left button to return to last page, and press **menu** to exit the menu.

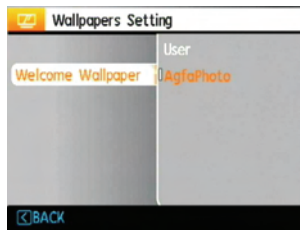

- User
- AgfaPhoto

## Back To Default

Use Up/Down button to select Back To Default, press **func** to confirm or press Left button to return to last page, and press **menu** to exit the menu.



- Yes
- No

## Setup Menu

**Mode**



The Setup menu for the camera is available in all modes. Each menu page can be selected by pressing the **menu** button and switching between menus with the Left/Right button.

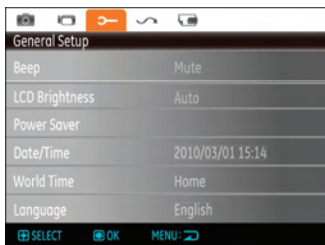

To adjust the settings:

1. Select the menu page with the function you want to adjust and press the Down button.
2. Switch between different functions with the **Up/Down** button.
3. Press the **Right** button to enter the submenu.



After selecting a function option, you can press the Up button to return to the menu for other Camera Setup pages. Or you can press the Down button to switch to the next menu page.

Refer to the following pages for more details about each setting.

## Beep

Use this setting to adjust the volume of beep when buttons are pressed and change the tones for Shutter button, self-timer, and power-on/power-off.

To change this setting:

1. Select the **Beep** setting from the **Setup** menu as described previously.
2. Use the **Up/Down** navigation buttons to switch between volume, shutter tone, key tone, self-timer tone, and power tone fields.

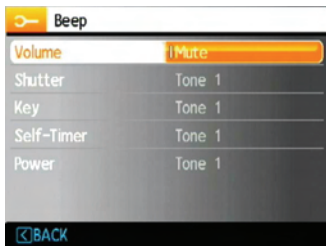

3. Press the Right button, press the Up/Down button to adjust volume and change tone, and press the **func ok** button to confirm setting.

## LCD Brightness

Use this setting to adjust the brightness of your LCD screen.

1. Select the **LCD Brightness** setting from the **Setup** menu as described previously.
2. Select auto or adjust the brightness level using the Left/Right button, and press the **func ok** button to confirm the setting.

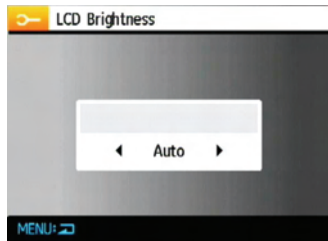

## Power Saver

This setting allows you to save power and get the maximum possible running time for your battery. Follow the steps below to turn off the LCD screen and camera automatically after a period of inactivity.

1. Select the **Power Save** setting from the **Setup** menu as described previously.
2. Press the Up/Down button to select the power items for the screen and camera and press the Right button.



3. Press the Up/Down button to adjust the selected item. Both items have the following options:

- Turn off the LCD:  
30 sec, 1 min, 2 min, and off.
  - Turn off the camera:  
3 min, 5 min, 10 min, and off.
4. Press the  $\text{func}_{\text{ok}}$  button to confirm.

## Zone

The Zone setting is a useful function on your overseas trips. This feature enables you to display the local time on the LCD screen while you are overseas.

1. Select the **Zone** setting from the **Setup** menu as described previously. The world time screen appears.
2. Use the **Up/Down** navigation buttons to switch between the hometown ( ) and travel destination ( ) fields.
3. Use the **Left/Right** navigation buttons to select a city close to the desired time zone. Then press the  $\text{func}_{\text{ok}}$  button to confirm.



## Date/Time

See "**Setting the Date and Time**" section on page 15.

## Language

See "**Setting the Language**" section on page 16.

## File and Software

### Format Memory

Please note: formatting enables you to delete all contents in the memory card and built-in memory, including protected photo and movie files.

To use this setting:

1. Select the Format in File and Software menu.
2. Use the **Up/Down** navigation buttons to select **Yes** or **No**. Then press the  $\text{func}_{\text{ok}}$  button to confirm.

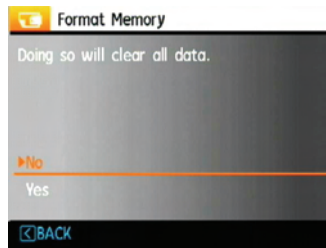

3. The current media is formatted.

## File Numbering

After you take a picture or video clip, the camera will save it as file that ends with a serial number. You can use this item to choose whether the file is consecutively numbered or begins with 1 and is saved in another folder on the memory card.

1. Select the File Name in File and Software menu.
2. Select the option with the Up/Down button and press the  $\text{func}_{\text{ok}}$  button for confirmation.

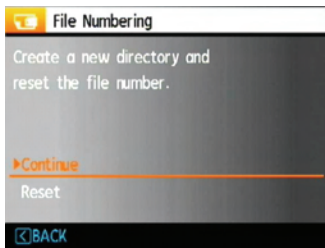

## Copy to Card (Copy internal memory to memory card)

Use this setting to copy the files stored in the internal memory to the memory card.

1. Select the **Copy to memory card** in File and Software menu.
2. Use the **Up/Down** navigation buttons to select **Yes** or **No**. Then press the  $\text{func}_{\text{ok}}$  button to confirm.

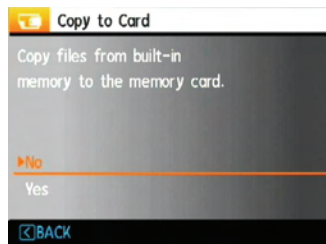

## Reset Settings

Use this setting to restore the camera to its default settings.

1. Select the **Reset** setting in File and Software menu.
2. Use the **Up/Down** navigation buttons to select **Yes** or **No**. Then press the  $\text{func}$   
 $\text{ok}$  button to confirm.

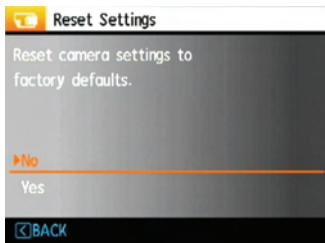

## FW Version (Firmware Version)

Use this setting to view the current camera firmware version.

1. Select the **FW Version** in File and Software menu.
2. If SD card contains a new version of firmware, please upgrade accordingly as necessary.

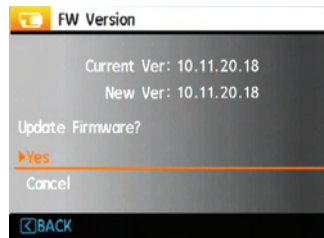

To inform to the latest firmware version, you can go to the following website [www.plawa.com](http://www.plawa.com)



# Transmission

## Video System

Use this setting to determine your video system in the current area.

1. Select the **Video System** in Connection **Transmission** menu.
2. Use the **Up/Down** navigation buttons to select **NTSC** or **PAL**. Then press the <sup>func</sup>ok button to confirm.

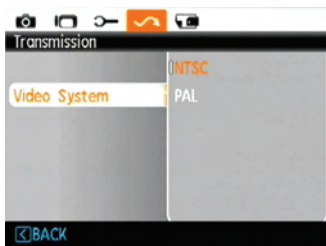

The video output signal can be switched to NTSC or PAL to accommodate different regional standards. The appropriate setting will vary between regions.

**NTSC:** USA, Canada, Taiwan, Japan, etc.

**PAL:** Europe, Asia (excluding Taiwan), Oceania, etc.

**Note:** The TV output will not display properly if an incorrect video system is selected.

## Connecting to a PC

Use the USB cable supplied with your camera to copy (transfer) pictures to a computer.

### Setting the USB Mode

Since the camera's USB port can be set to connect with either a PC or a Printer, the following steps will allow you to ensure that the camera is correctly configured to connect with a PC. The USB mode is set to PC by default.

1. Go to the transmission menu, select USB connection with the Up/Down button, and press the Right button.
2. Use the **Up/Down** navigation buttons to select **PC**.
3. Press the **func/ok** button to confirm the setting.

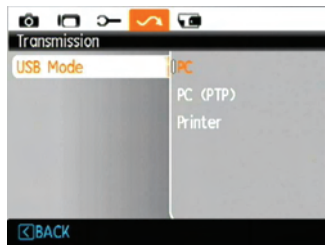

### Transferring Files to Your PC

The computer will automatically detect the camera as a removable drive. Double-click **My Computer** icon on the desktop to locate the removable drive and to copy the folders and files in the drive to a directory on your PC as you would copy any other folder or file.

By using the USB cable, you can transfer the captured photos and videos to a PC. Follow the steps below to connect the camera to a PC.

1. Make sure both the camera and PC are turned on.
2. Connect one end of the supplied USB cable to the USB/AV OUT port on your camera.
3. Connect the other end of the cable to an available USB port on your PC.

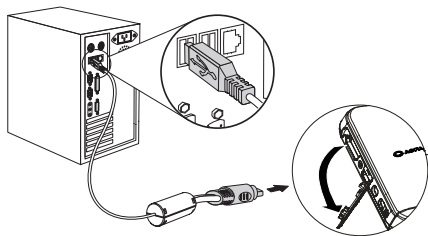

4. Disconnect the camera once transfer is completed.

**If the USB option is set to [PC] :**

Turn the camera off and disconnect the USB cable.

**If the USB option is set to [PC (PTP)] :**

Remove the camera from the system as described below before turning the camera off and disconnecting the USB cable.

Windows operating system (Windows 2000, Windows XP, Windows Vista, Windows 7.)

Click the [Safely remove the hardware] icon and remove the USB connector according to the appeared menu.

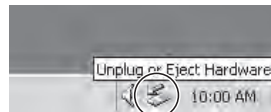

Macintosh

Drag the untitled icon to the Trash. ("Untitled")



# APPENDICES

## Specifications: OPTIMA 3



Design and specifications are subject to change without notice.

Effective Image Sensor Pixels		14.1 Megapixels
Image Sensor		14.2 Megapixels [1/2.3" (CCD)]
Lens	Focal Length F =	5.1mm (Wide) ~ 40.8mm (Tele)
	35mm film equivalent	28mm (Wide) ~ 224mm (Tele)
	Brightness	F3.3 (Wide) ~ F5.8 (Tele)
	Lens type	12 elements in 8 groups
	Optical Zoom	8X
	Focusing Range	Normal: (Wide) 60cm ~ ∞, (Tele) 100cm ~ ∞; Macro: 5cm ~ ∞ (Wide only)
Anti-Handshake		OIS
Digital Zoom		6X digital zoom (Combined Zoom: 48X)

Number of Recording Pixels	Still Image	14MP, 12MP(3:2), 10MP(16:9), 8MP, 5MP, 3MP, 2MP, 0.3MP
	Movie	1280x720pixels: 30fps/15fps, 640x480pixels: 30fps/15fps, 320x240pixels: 30fps/15fps
Exposure Metering		Best, Fine, Normal
DCF, DPOF (Ver1.1) Support		Yes
File Format	Still Image	Exif 2.2 (JPEG)
	Movie	MPEG-4/H.264, Audio: G.711 [Monaural]
Shooting Modes		Auto, Manual, Auto-Scene, Scene (Sport, Indoor, Snow, Fireworks, Museum, Night Landscape, Children, Leaf, Sunset, Glass, Landscape, Night Portrait), Portrait, Panorama, Video
Smile Detection		Yes
Blink Detection		Yes
Face-Detection		Yes
Red-eye Removal		Yes

Pan-Capture Panorama	Yes
LCD Display	3.0 inch (230,400 pixels) LTPS (low-temperature polycrystalline silicon) TFT color LCD
ISO Sensitivity	Auto, ISO 80/100/200/400/800/1600/3200
AF Method	Spot, Center-Weight, AiAE (Artificial Intelligence AE)
Light Metering Method	Artificial Intelligence AE (AiAE), Center-weighted Average, Spot (Fixed to center of frame)
Exposure Control Method	ProgramAE (AE-lock available)
Exposure Compensation	±2 EV in 1/3 Step increments
Shutter Speed	4 ~ 1/2000 second (Manual 30 s)
Continuous Shooting	Approx. 1.39 fps (Large/Fine mode)
Playback Modes	Single Photo, Index (4/9/16 thumbnails), Slide Show, Movie (Slow-Motion possible), Zoom (Approx. 2X~8X), Audio, Histogram Display
White Balance Control	Auto (AWB), Daylight, Cloudy, Fluorescent , Fluorescent CWF, Incandescent, Manual

Internal Flash (Shooting Range)	Auto/Red-Eye Reduction/Forced Flash/No Flash/Slow Synchro/Red-Eye Reduction+Slow Synchro
	Shooting Range Wide: Approx. 0.3m~5.1m / Tele: Approx. 1.0m ~ 2.8m (ISO 800)
Recording Media	Internal Memory: 32 MB (12 MB available to store images and videos)
	SD Card/SDHC Card (Up to 16GB support)
Other Features	Exif Print Support, Multi-language Support
Jacks	USB2.0/AV-OUT (Integrated Proprietary Connector)
Power	Rechargeable Lithium-ion Battery D016, 3.7V 700mAh
Shooting Capability (Battery Performance)	Approx. 180 shots (based on CIPA Standards)
Operation Environment	Temperature: 0~40°C, Humidity: 0~90%
Dimensions (W x H x D)	98.5mm x 57.3mm x (21~24.8)mm
Mass	Approx. 146g (Body only)

## Error messages

Messages	Explanation
No card	<ul style="list-style-type: none"> <li>The memory card is not inserted.</li> </ul>
Card error	<ul style="list-style-type: none"> <li>The memory card is not formatted.</li> </ul>
Card full	<ul style="list-style-type: none"> <li>The memory card is full and cannot store any new images.</li> </ul>
Write protect	<ul style="list-style-type: none"> <li>The memory card is write-protected.</li> </ul>
Picture error	<ul style="list-style-type: none"> <li>The picture is not captured correctly.</li> <li>The picture is corrupted.</li> </ul>
No picture	<ul style="list-style-type: none"> <li>There are no images in the memory card or in the internal memory.</li> </ul>
Lens error	<ul style="list-style-type: none"> <li>The lens is probably stuck and the camera will power off automatically.</li> </ul>
System error	<ul style="list-style-type: none"> <li>Unexpected error encountered.</li> </ul>
Image cannot be saved	<ul style="list-style-type: none"> <li>The write protection switch in the memory card is set to the "LOCK" position.</li> </ul>
Out of the range	<ul style="list-style-type: none"> <li>When pictures were taken in Panorama mode, the direction of movement was incorrect.</li> </ul>



Messages	Explanation
Card is not formatted, format?	<ul style="list-style-type: none"><li>• Confirm whether the memory card should be formatted.</li></ul>
This image cannot be deleted	<ul style="list-style-type: none"><li>• The picture or video you are trying to delete is protected.</li></ul>
Cannot record movie	<ul style="list-style-type: none"><li>• The write protection switch in the memory card is set to the "LOCK" position.</li></ul>
Warning!! Camera recording, please wait.	<ul style="list-style-type: none"><li>• No other actions allowed to perform during video/audio recording.</li></ul>
Warning!! Battery exhausted.	<ul style="list-style-type: none"><li>• The battery is drained.</li></ul>
This file cannot be played back	<ul style="list-style-type: none"><li>• The picture format cannot be recognized by the camera.</li></ul>
No connection	<ul style="list-style-type: none"><li>• The camera is not connected to the printer correctly.</li></ul>
Print error	<ul style="list-style-type: none"><li>• There is a problem with camera or printer.</li></ul>
Cannot print	<ul style="list-style-type: none"><li>• Check that the printer is out of paper or out of ink.</li><li>• Check if the printer has a paper jam.</li></ul>

## Troubleshooting

Problem	Possible causes	Solution
Camera does not turn on.	<ul style="list-style-type: none"> <li>The battery has run out.</li> <li>The battery is not inserted correctly.</li> </ul>	<ul style="list-style-type: none"> <li>Replace with a fully charged battery.</li> </ul>
Camera turns off suddenly during operation.	<ul style="list-style-type: none"> <li>The battery has run out.</li> </ul>	<ul style="list-style-type: none"> <li>Replace with a fully charged battery.</li> </ul>
The picture is blurred.	<ul style="list-style-type: none"> <li>The lens is dirty.</li> <li> appears when taking pictures.</li> </ul>	<ul style="list-style-type: none"> <li>Use a soft cloth to clean the lens on your camera</li> <li>Use the <b>OIS</b> mode.</li> </ul>
Images and video files cannot be saved.	<ul style="list-style-type: none"> <li>The memory card is full.</li> </ul>	<ul style="list-style-type: none"> <li>Replace the memory card with a new one.</li> <li>Delete unwanted images.</li> <li>Unlock the memory card.</li> </ul>
No picture is taken when pressing the Shutter button.	<ul style="list-style-type: none"> <li>The memory card is full.</li> <li>No available space to store the files.</li> <li>The mode dial is in <b>Playback</b> mode.</li> </ul>	<ul style="list-style-type: none"> <li>Replace the memory card with a new one or clean off current memory card.</li> <li>Delete unwanted images.</li> <li>The memory card is locked.</li> </ul>

## Customer Care

More information on the complete AgfaPhoto digital camera product range can be found at [www.plawa.com](http://www.plawa.com) / [www.agfaphoto.com](http://www.agfaphoto.com).

**Service & Repair Hotline (EU):**

00800 752 921 00 (from a landline only)

**Service & Repair (UK):**

+44 1908 488676, [info@allmondgroup.com](mailto:info@allmondgroup.com)

**Service & Support Hotline (Germany):**

0900 1000 042 (1.49 euro / min. from a German landline only)

**Online Service / International contact:**

[support-apdc@plawa.com](mailto:support-apdc@plawa.com)

**Manufactured by**

plawa-feinwerktechnik GmbH & Co. KG  
Bleichereistraße 18  
73066 Uhingen  
Germany

Allmonde Group Limited, 218 Fairbourne Drive, Atterbury, Milton Keynes, MK10 9RG, United Kingdom

AgfaPhoto is used under license of Agfa-Gevaert NV & Co. KG or Agfa-Gevaert NV. Neither Agfa-Gevaert NV & Co KG nor Agfa-Gevaert NV manufacture this product or provide any product warranty or support. For service, support and warranty information, contact the distributor or manufacturer. All other brands and product names are registered trademarks of their respective owners. Product design and technical features can be changed without notice. Contact: AgfaPhoto Holding GmbH, [www.agfaphoto.com](http://www.agfaphoto.com)



AgfaPhoto is used under license of Agfa-Gevaert NV & Co. KG or Agfa-Gevaert NV. Neither Agfa-Gevaert NV & Co. KG nor Agfa-Gevaert NV manufacture this product or provide any product warranty or support. For service, support and warranty information, contact the distributor or manufacturer. For service, support and warranty information, contact the distributor or manufacturer. All other brands and product names are registered trademarks of their respective owners. Product design and technical features can be changed without notice.

AgfaPhoto Holding GmbH, [www.agfaphoto.com](http://www.agfaphoto.com)  
Manufactured by plawa-feinwerktechnik GmbH & Co. KG, [www.plawa.com](http://www.plawa.com)