

DC-830s

User manual



Thank you for purchasing this AgfaPhoto digital camera. Please read these operating instructions carefully in order to use the digital camera correctly. Keep the instructions in a safe place after reading so that you can refer to them later.

Precautions

- Do not point the camera directly into the sun or other intense light sources which could damage your eyesight.
- Do not try to open the casing of the camera or attempt to modify this camera in any way. High-voltage internal components create the risk of electric shock when exposed. Maintenance and repairs should be carried out only by authorized service providers.
- Do not fire the flash too close to the eyes of animals or young children. Eye damage may result. Please remain at least one meter away from infants when using the flash.
- Keep the camera away from water and other liquids. Do not use the camera with wet hands. Never use the camera in the rain or snow. Internal moisture is dangerous and may lead to electric shock.
- Keep the camera and its accessories out of the reach of children and animals to prevent accidents or damage to the camera.
- If you notice smoke or a strange odor coming from the camera, turn the power off immediately. Take the camera to the nearest authorized service center for repair. Never attempt to repair the camera yourself.
- Use only the recommended power accessories. Use of power sources not expressly recommended for this equipment may lead to overheating, distortion of the equipment, fire, electrical shock or other hazards.

Disclaimer

We assume no responsibility over and above the provisions of the Product Liability Law for damages suffered by the user or third parties as a result of the inappropriate handling of the product or its accessories, or by their operational failure and by their use. We reserve the right to make changes to this product and its accessories without prior notice.

Warning!

Never open the camera or remove any parts of it. This will void all warranty claims.

Using your batteries

For best performance and prolonged battery life, we recommend the use of rechargeable Ni-MH batteries.

Extending battery life

Excessive use of the following functions use up a great deal of battery power and should therefore only be used occasionally:

- Flash
- Editing images on the camera display

The battery life can be affected by soiling. Please clean the contacts with a clean, dry cloth before putting the batteries in the camera. Battery performance drops at temperatures below 0° C. If you use the camera at low temperatures you should have replacement batteries to hand and ensure they do not get too cold.

Please note: you should not dispose of cold and seemingly flat batteries because these batteries may work again at room temperature.

1. Table of Contents

Precautions	1	Backlight Mode.....	16
Disclaimer.....	1	Candle Light Mode	16
Warning!.....	1	Auction Mode	17
Using your batteries	1	6. Menu Mode	18
Extending battery life.....	1	Mode Set.....	18
1. Table of Contents	2	Image Size (Default: 8M).....	18
2. General Introduction	3	Metering (Default: Multi).....	18
Package Contents	3	Sharpness (Default: Normal).....	18
External View	3	Quality (Default: FINE)	18
Display Information.....	5	Shooting (Continuous) (Default: Single)..	18
3. Getting Started	7	Effect (Default: Normal).....	19
Turning Power On & Off	7	OSD Information (Default: Detail).....	19
Inserting / Removing the Batteries	7	Face Detection (Default: On).....	19
Inserting /Removing a Memory Card.....	8	7. Movie Clip Mode	20
Attaching the Wrist Strap.....	8	Size 20	
4. Buttons & Functions	9	Metering	20
Turning Power On & Off	9	Multi Metering:.....	20
Shutter.....	9	Spot Metering:	20
Tele / Wide	9	Effect20	
Playback.....	10	OSD Information.....	20
Mode10		8. Voice Recording Mode	21
Basic Operations	10	9. Playback Mode	22
EV.....	10	Protect.....	22
ISO	11	Slide 22	
WB.....	11	Delete	23
Menu12		DPOF	23
Up / Play & Pause / Macro	12	Copy To Card	23
Right / Flash	12	Resize	24
Down / Voice Memo	12	Rotate.....	24
Left / Self-timer	13	Effect24	
5. Still Image Mode	14	10. Set Up Mode	25
Capturing Images	14	11. PC Connection	27
Mode Set.....	14	12. Specifications	28
Auto Mode	14	13. Customer care	30
Program Mode.....	15	Customer care.....	30
Portrait Mode.....	15	Disposal of Waste Equipment by Users	
Night Portrait Mode	15	in Private Households in the European	
Sunset Mode	15	Union	31
Fireworks Mode.....	15	FCC Compliance and Advisory	31
Beach Mode	16		
Landscape Mode.....	16		
Night Landscape Mode	16		

2. General Introduction

Package Contents

AgfaPhoto
DC-830s

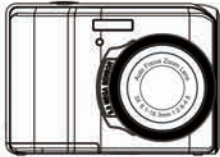

Camera Driver &
Software CD



Quick Guide

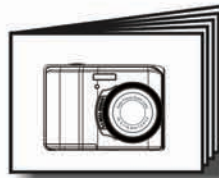

USB Cable

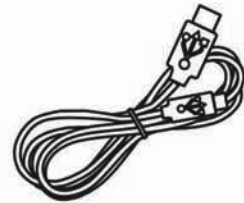

Wrist Strap



Camera Pouch



2xAA Batteries



External View

Top

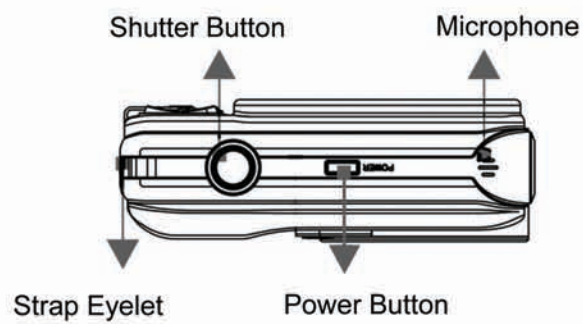

Side

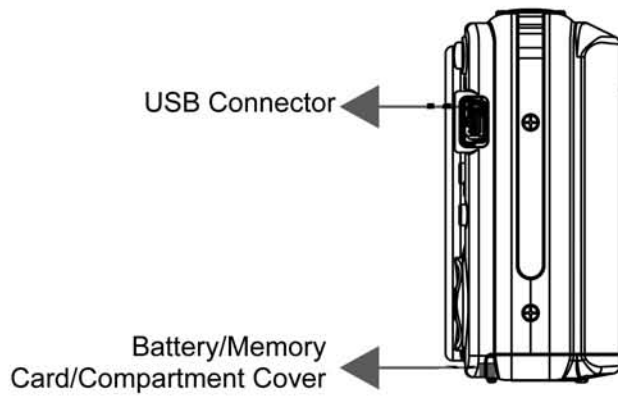

Front

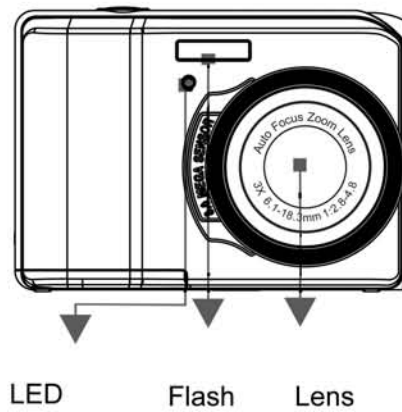

Back

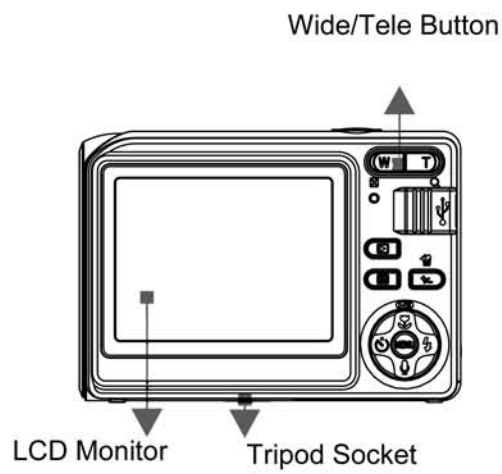

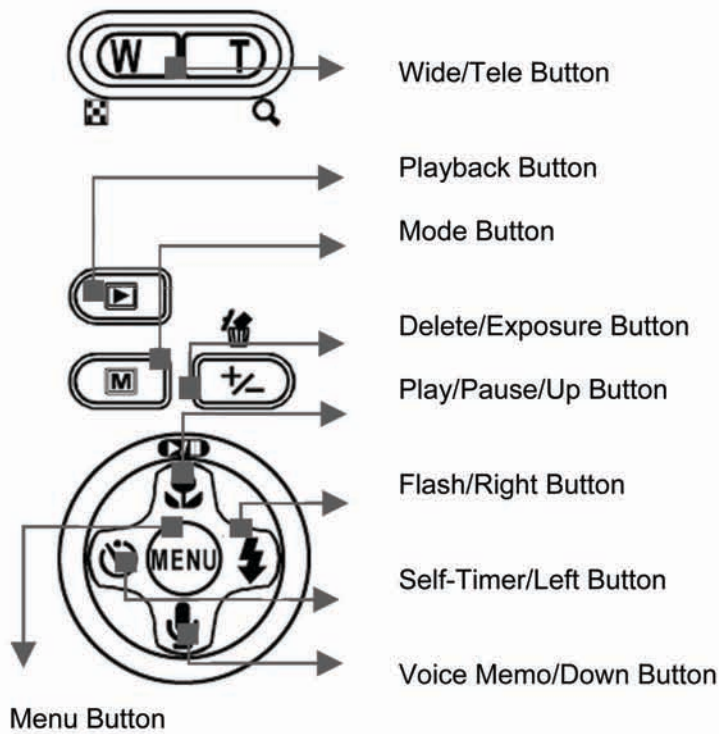

Display Information

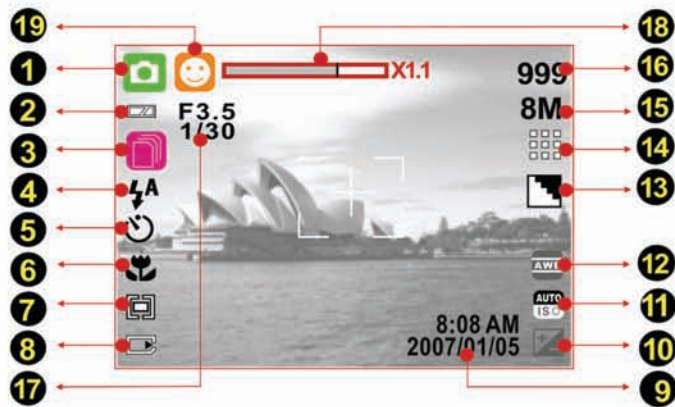

1. Operation Mode



- () Auto
- () Program
- () Portrait
- () Landscape
- () Night Portrait
- () Night Landscape
- () Sunset
- () Backlight
- () Fireworks

- () Candle Light
- () Beach
- () Auction
- () Movie Clip Mode
- () Voice Recording Mode





2. Battery Status

- () Batteries Full
- () Batteries Half Full
- () Batteries Empty



3. Shooting Mode

- () Single
- () Continuous

4. Flash Mode

- () Auto Flash
- () Red-Eye
- () Fill-in Flash
- () Slow Sync
- () Flash Off

5. Self-timer

- () 10 Seconds
- () 2 Seconds
- () Double

6. Focus Range

- () Macro

7. Metering

- () Multi
- () Spot





8. Memory Status

- () Memory Card Inserted







9. Time & Date

- 10. () Exposure $\pm 2EV$
0.5 EV Steps

11. ISO Value

- () Auto
- () 100
- () 200
- () 400
- () 800



12. W. Balance

- () Auto
- () Daylight
- () Cloudy
- () Sunset
- () Fluorescent
- () Tungsten
- () Custom

13. Sharpness

- () Soft
- () Normal
- () Vivid

14. Quality

- () Super Fine
- () Fine
- () Normal

15. Image Size

Still Image

- (8M) 3264 x 2448
- (5M) 2592 x 1944
- (3M) 2048 x 1536
- (1M) 1280 x 960

Movie Clip

- (720) 720 x 480
- (640) 640 x 480
- (320) 320 x 240

16. Estimated Available Shots & Video Time

17. F No. & Shutter Speed

18. Zoom Status Indicator

- 19. () Face Detection

3. Getting Started

Turning Power On & Off

- Press the Power Button to turn the camera on.
- Press the Power Button again to turn the camera off.



Inserting / Removing the Batteries

1. Power off the camera.
2. Slide open the battery compartment cover.
3. Remove the batteries or, respecting the polarity indications, insert them.
4. Close the battery cover.

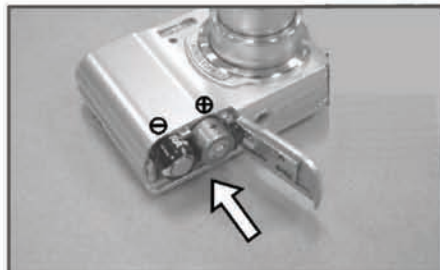

Battery status indicator.

(): Batteries full.

(): Batteries half full.

(): Batteries empty. Replace with new batteries.

- The batteries will discharge if kept inside the camera for a long time without use. Remove the batteries when the camera is not in use.
- The batteries may not work normally under 0°C or over 40°C.

Inserting /Removing a Memory Card

1. Power off the camera.
2. Open the battery compartment cover.
3. Insert the memory card into the card slot and press it gently until you hear a click.
4. To remove, gently press on the edge of the card and pull it out.
5. Close the battery cover.



Attaching the Wrist Strap



4. Buttons & Functions

Turning Power On & Off

- Press the Power Button to turn the camera on.
- Press the Power Button again to turn the camera off.

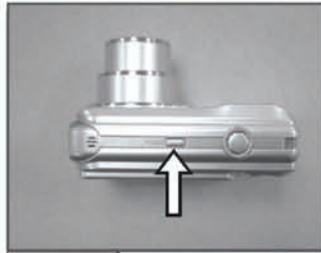

Power

- If the camera is left idle for a certain period of time, the camera will power off automatically.

Shutter

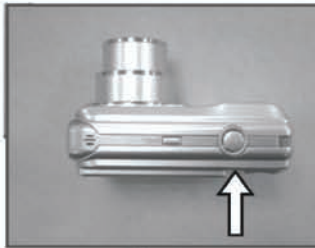

Shutter

- Press the shutter button half way to focus and then press it fully down to capture an image.

Tele / Wide

- Press the Tele Button. The Zoom Bar Indicator will appear in the top of the LCD display showing the current zoom status.
- Press the Wide Button. The Zoom Bar Indicator will return to the Wide view.
- The camera allows maximum 3.0x optical zoom and 5.0x digital zoom.



Playback

- You can use the playback mode to replay, delete or edit images on the LCD.
- Select the Playback Mode by pressing the Playback Button ().
- Playback Mode displays still images, movie clips and voice recordings.
- Select an image by pressing the Left or Right Button.
- Press and hold the Left or Right Button to fast forward the images.



Mode

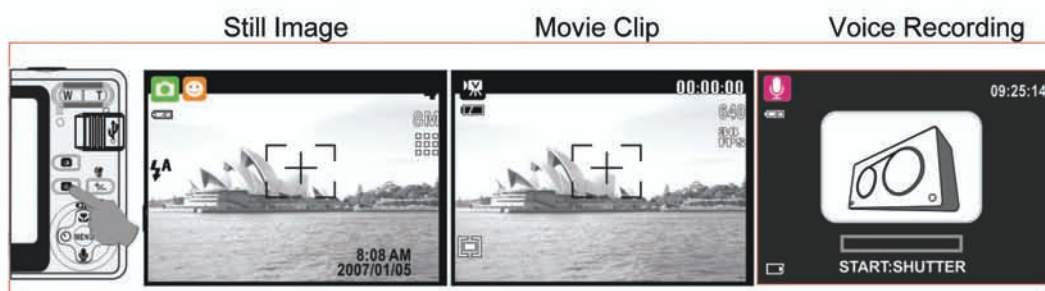

Basic Operations

- To adjust white balance and ISO select Program Mode ().

EV

- To adjust the EV value, press the Delete / Exposure Button ().
- Press Left / Right Button to set the Exposure Value.
- You can adjust from -2.0EV to +2.0EV (in 0.5EV steps).
- After the preferred value has been selected press the Menu Button to confirm the setting.
- The higher the EV value, the brighter the image will be.



ISO







- To adjust the ISO value, select Program Mode and press the Delete / Exposure Button (⊖/⊕).
- Press the up or down button to toggle between EV, ISO and white balance.
- Press the Right / Left Button to set the ISO value and press the Menu Button to confirm.



WB

- To adjust the WB value, select Program Mode and press the Delete / Exposure Button (⊖/⊕).
- Press the up or down button to toggle between EV, ISO and white balance.
- Press the Right / Left Button to set the WB value and press the Menu Button to confirm.





	Auto	Adjusts the white balance automatically
	Daylight	For bright light conditions
	Cloudy	For cloudy conditions
	Sunset	For sunsets/twilight conditions
	Fluorescent	For florescent light
	Tungsten	For tungsten light
	Custom	Under lighting conditions different from the above ones

Menu

- Press the Menu Button open the menu.
- When the menu appears on the LCD display, the Menu Button is used to move through the highlighted items in the submenu or to select a menu item.

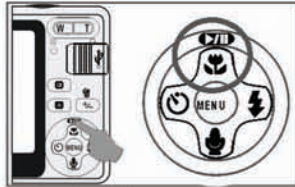

Up / Play & Pause / Macro

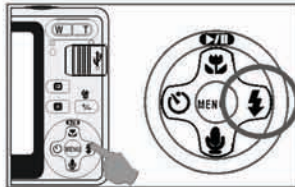

- Press the Up Button () to move up the submenu.
- When the menu is not displayed on the LCD display, the Up Button () operates as the Macro function.
- The Up Button also operates as the Play & Pause function to play voice recordings & movie clips in Playback Mode.

Right / Flash



- Press the Right Button () to highlight items in the right tab.
- The Right Button () also operates as the Flash function.

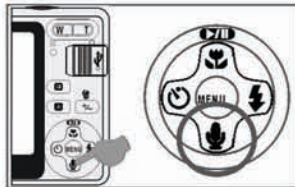

Down / Voice Memo



- Press the Voice Button () to highlight items in the down tab.
- There are two ways you can add your voice to a stored still image.
 1. Shooting Mode
 2. Playback Mode

Left / Self-timer



- Press the Left Button to highlight items in the left tab.
10 sec. Self-timer (): The image will be taken 10 seconds after the shutter is released.
2 sec. Self-timer (): The image will be taken 2 seconds after the shutter is released.
With the Double Self-timer (): The first image will be taken after 10 seconds. The second image will be taken a few seconds after the first shot. Two pictures will be taken once the shutter is released.

5. Still Image Mode

Capturing Images

Taking a Picture

1. Press Power Button to power on the camera.
2. Press the Shutter Button half way to focus.
3. Press Shutter Button fully to capture the image.

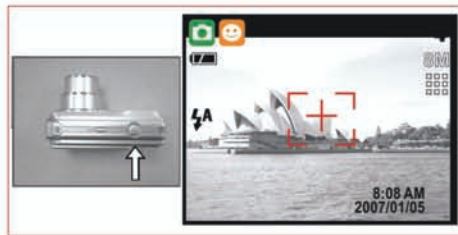

- Using the Zoom
Press T or W on the Zoom Button



It is recommended that you take photos with the camera mounted on a tripod or other device if the Shaking Hand () icon appears.

Mode Set

Auto Mode

In this mode the following settings will be automatically locked at the factory default settings and cannot be adjusted.

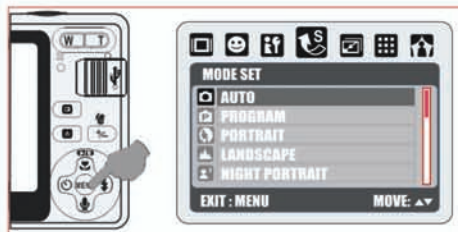

- (a) Metering: Multi
- (b) Sharpness: Normal
- (c) Effect: Normal
- (d) Shooting (Continuous Shooting): Single
- (e) Available Flash modes:
 - (1) Auto Flash
 - (2) Red-eye Reduction
 - (3) Flash Off

Program Mode

After the above procedure, you can press the Menu Button again to configure your own settings for the image.

In Program Mode, metering, sharpness, effect, white balance, shooting flash & ISO can be adjusted.

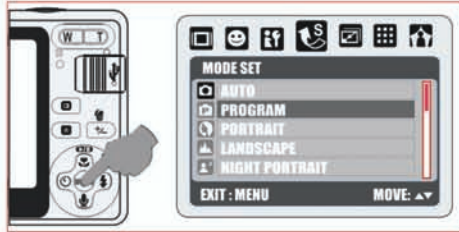

Portrait Mode

In this mode the settings will be locked as indicated below:

- (a) Metering: Multi
- (b) Sharpness: Normal
- (c) Shooting (Continuous Shooting): Single
- (d) Available Flash modes:
 - (1) Auto Flash
 - (2) Red-eye Reduction
 - (3) Flash Off

Night Portrait Mode

In this mode the settings will be locked as indicated below:

- (a) Metering: Multi
- (b) Sharpness: Normal
- (c) Effect: Normal
- (d) Shooting (Continuous Shooting): Single
- (e) Available Flash modes:
 - (1) Auto Flash
 - (2) Red-eye Reduction
 - (3) Fill-in Flash
 - (4) Slow Sync
 - (5) Flash off

Sunset Mode

In this mode the settings will be locked as indicated below:

- (a) Metering: Multi
- (b) Sharpness: Normal
- (c) Effect: Normal
- (d) White Balance: Daylight
- (e) Shooting (Continuous Shooting): Single
- (f) Flash: Off

Fireworks Mode

In this mode the settings will be locked as indicated below:

- (a) Metering: Multi
- (b) Sharpness: Normal
- (c) Effect: Normal
- (d) White Balance: Daylight
- (e) Shooting (Continuous Shooting): Single
- (f) Flash: Off

Beach Mode

In this mode the settings will be locked as indicated below:

- (a) Metering: Multi
- (b) Sharpness: Normal
- (c) Effect: Normal
- (d) Shooting (Continuous Shooting): Single
- (e) Available Flash modes:
 - (1) Auto Flash
 - (2) Red-eye Reduction
 - (3) Flash off

Landscape Mode

In this mode the settings will be locked as indicated below:

- (a) Metering: Multi
- (b) Sharpness: Normal
- (c) Effect: Normal
- (d) Shooting (Continuous Shooting): Single
- (e) Available Flash modes:
 - (1) Auto Flash
 - (2) Red-eye Reduction
 - (3) Flash Off

Night Landscape Mode

In this mode the settings will be locked as indicated below:

- (a) Metering: Multi
- (b) Sharpness: Normal
- (c) Effect: Normal
- (d) White Balance: Auto
- (e) Photo Frame: Off
- (f) Shooting (Continuous Shooting): Single
- (g) Available Flash modes:
 - (1) Slow Sync
 - (2) Flash Off

Backlight Mode

In this mode the settings will be locked as indicated below:

- (a) Metering: Multi
- (b) Sharpness: Normal
- (c) Effect: Normal
- (d) Shooting (Continuous Shooting): Single
- (e) Flash: Fill-in

Candle Light Mode

In this mode the settings will be locked as indicated below:

- (a) Metering: Multi
- (b) Sharpness: Normal
- (c) Effect: Normal
- (d) White Balance: Daylight
- (e) Shooting (Continuous Shooting): Single
- (f) Flash: Off

Auction Mode

In this mode the settings will be locked as indicated below:

- (a) Metering: Multi
- (b) Sharpness: Normal
- (c) Effect: Normal
- (d) Shooting (Continuous Shooting): Single
- (e) Flash: Off

6. Menu Mode

Mode Set

Here you can select the scene mode from the following options:

- | | |
|---|--|
| () Auto | () Sunset |
| () Program | () Backlight |
| () Portrait | () Fireworks |
| () Landscape | () Candle Light |
| () Night Portrait | () Beach |
| () Night Landscape | () Auction |

Image Size (Default: 8M)

This feature is for you to select the image resolution.

- (8M) 3264 x 2448
- (5M) 2592 x 1944
- (3M) 2048 x 1536
- (1M) 1280 x 960

Metering (Default: Multi)

The Metering Setting allows you to obtain superior exposure conditions and to capture a brighter picture.



Multi Metering ()

Exposure will be evaluated according to the average of the available light sources in the image area. This is suitable for general use.

Spot Metering ()



If the subject is against the light source or has little contrast, you can use this function to have the subject made brighter.

Sharpness (Default: Normal)



SOFT		This effect makes the edges of the captured image look smoother, making it suitable for image editing on PC.
NORMAL		This effect emphasizes the edges, making the captured image suitable for printing.
VIVID		This effect emphasizes the edges. The captured image looks sharper but may result in more image noise.

Quality (Default: FINE)

This feature allows you to select image quality for photo & video from the following options.

- () S. FINE (Super Fine)
- () FINE
- () NORMAL





Shooting (Continuous) (Default: Single)

1. SINGLE (): Single Image capture.
2. CONTINUOUS (): Press and hold down the Shutter Button to start the continuous shooting function and release to end.

Note:

The Continuous Shooting function will not be cancelled until "Single" is selected.

Effect (Default: Normal)

NORMAL		No special effect is added to the picture.
B&W		Turns the image black and white.
SEPIA		Gives the image a yellowish brown tone.
NEGATIVE		Gives the image a negative photo effect.

OSD Information (Default: Detail)

There are 5 options for the OSD information.

1. OFF: No OSD information is displayed.
2. BASIC: Only basic information is displayed.
3. DETAIL: Detailed information is displayed.
4. GRID 3X3: Grid lines for 9 grids will show on the LCD display for you to compose an image.
5. GRID 6X4: Grid lines for 24 grids will show on the LCD display for you to compose an image.

Note:

Select "OFF" to cancel the grid lines if you prefer not to use them for the next image.

Face Detection (Default: On)

What You Should Know Before Using Face Detection

Face Detection allows you to focus on human faces. It is effective with the camera held horizontally or vertically.

- Face Detection can only be used for still images.
- Face Detection is effective within a range of 2.5m.



Subjects not suitable for Face Detection:

1. A face that is obscured by glasses, a hat or hair.
2. A person who is turned sideways, or who has their head turned.
3. A subject who is too far away to distinguish a face.

7. Movie Clip Mode

Size

The video size options provided are as follows:

1.  720 x 480
2.  640x 480
3.  320 x 240

Metering

The Metering Setting allows you to obtain superior exposure conditions and to capture a brighter picture.





Multi Metering:

Press the (MENU) Button on the camera to switch to Movie Clip Mode. Press the Menu Button, then select Metering Mode. The Exposure will be evaluated according to the average of the available light sources in the image area. This is suitable for general use.

Spot Metering:

Press the (MENU) Button on the camera to switch to Movie Clip Mode. Press the Menu Button, then select Metering Mode. If the subject is against the light source or has little contrast, you can use this function to have the subject made brighter.

Effect

NORMAL		No special effect is added to the picture.
B&W		Turns the image black and white.
SEPIA		Gives the image a yellowish brown tone.
NEGATIVE		Gives the image a negative photo effect.



OSD Information

There are 3 options for the OSD information.

1. OFF : No OSD information is displayed.
2. BASIC : Only basic information is displayed.
3. DETAIL : Detailed information is displayed.

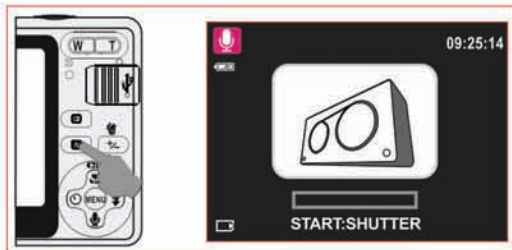
8. Voice Recording Mode







1. Press the Mode Button and select the Voice Recording Mode ().
2. Press the Shutter Button to start recording and press the Shutter Button again to stop recording.
3. Press the Play / Pause Button () during recording to pause recording and press the Play / Pause Button again to continue recording.

9. Playback Mode



Protect

Protecting Selected Image(s)

1. Press the Menu Button and select "PROTECT".
2. Choose "SELECT" and press the Menu Button to confirm the request.
3. Choose one image and press the T Button ()().
4. () will appear on the LCD when a file is protected.
5. Press the Menu Button to confirm the protection of the selected image(s).
6. To cancel the protection, press the T Button () or W Button ().
7. Press the Shutter Button (**EXIT : SH**) to return to "Playback Mode".







Protecting All Images

1. Press the Menu Button and select "PROTECT"..
2. Select "ALL" and press the Menu Button to confirm.
3. To cancel the protection, press the T Button () and W Button ().

Slide



Operation Steps

1. MENU
2.  or 
3.  or 

SHOW: This option allows you to start the slide show after you have made the INTERVAL and EFFECT settings.

Here you can also choose whether to play the slide show once or repeatedly.

INTERVAL: This option allows you to select the interval time between each still image.

EFFECT: This option allows you to select the effects of the slide show. There are 5 effects to choose from.

Note:

After having completed setting up INTERVAL and EFFECT, enter SHOW to select PLAY / REPEAT to start the slide show.

Delete



Operation Steps

1. MENU
2. ► or ◀
3. ▲ or ▼

There are 2 ways to DELETE images:

1. Press the Delete / Exposure Button ()
2. Select "Delete" on the display to delete the image or select "Cancel" to cancel the request.

Deleting All Images

1. Press the Menu Button and select "DELETE".
2. Select "ALL" and press the Menu Button.
3. Select "DELETE" to confirm the file deleting request or select "CANCEL" to cancel the request.
4. Press the Menu Button again to proceed.

DPOF



Operation Steps

1. MENU
2. ► or ◀
3. ▲ or ▼

This function can only be used when a memory card is inserted.

This option allows you to store the number of copies to print (MAX. 30 pcs) on your memory card.

[ONE PIC] - specifies the number of copies for a selected image.

[ALL PICS] - specifies the number of copies for all pictures apart from movie clips and voice recording files.

Note:

You cannot see the "PRINT" function on the LCD display if a memory card is not inserted.

Copy To Card



Operation Steps

1. MENU
2. ► or ◀
3. ▲ or ▼

This function allows you to copy the images stored in the internal flash memory onto a memory card.

Resize



Operation Steps

1. MENU
2. ► or ◀
3. ▲ or ▼

This function allows you to resize a still image.

1. Select the image you want to resize
2. Press the Menu Button and select "RESIZE".
3. Select the image size you prefer.
4. You can choose your own image as the start-up image by selecting "USER IMAGE 1" & "USER IMAGE 2".

Note:

To set the "USER IMAGE 1" & "USER IMAGE 2" as the start-up image please refer to "Start-up image" under Set Up Mode

Rotate



Operation Steps

1. MENU
2. ► or ◀
3. ▲ or ▼

This setting allows you to rotate the image RIGHT 90°, LEFT 90°, 180°, HORIZONTAL and VERTICAL.

1. Select the image you want to rotate.
2. Press Menu Button and select "ROTATE".
3. Select the rotation you prefer and press the Menu Button.
4. After rotating, the image will be stored as a new image.

Effect

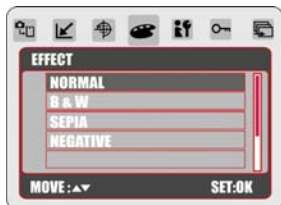

Operation Steps

1. MENU
2. ► or ◀
3. ▲ or ▼

This function allows you to apply a special effect to an image.

1. Select the image you want to apply a special effect to.
2. Press the Menu Button and select "EFFECT".
3. Select the special effect you prefer and press the Menu Button.
4. The image with the special effect will be stored as a new image.

10. Set Up Mode

You can enter the SETUP Mode by pressing the Menu Button and selecting SETUP.



Operation Steps

1. MENU
2. ► or ◀
3. ▲ or ▼



1. LCD
2. S. IMAGE
3. S. SOUND
4. SH. SOUND
5. SYS. VOLUME
6. Q.VIEW
7. PWR SAVE
8. IMPRINT
9. DATE & TIME
10. LANGUAGE
11. FILE
12. USB
13. FREQUENCY
14. RESET ALL
15. FORMAT

LCD



Start-up Image



Start Sound



Shutter Sound



Sys Vol



Quick View



Power Save



Imprint



Date & Time



Language



File



USB



Frequency

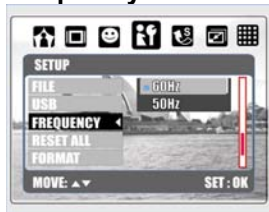

Reset All



Format



11. PC Connection

Computer / Notebook Connection

When the USB cable is connected to a Computer / Notebook / Disk Drive while the camera is on, the camera will automatically go to the PC mass storage Mode from any working mode. The display will turn off. In this Mode, you can download images to your computer.

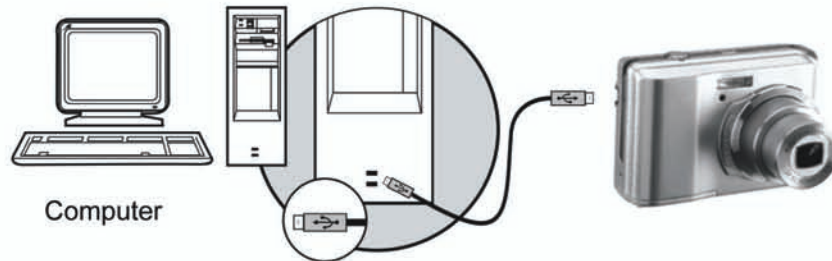

12. Specifications

Image Sensor	Type	1/2.5" 8M CMOS Sensor		
	Effective Pixels	8.0 Mega Pixels (3,264 × 2,448)		
Lens	Lens Type	Optical 3X Zoom (35mm Film Equivalent: 36~108 mm)		
	F No.	F2.8~F4.8		
	Digital Zoom	Still Image mode: 1.0X ~ 5.0X Play mode: 1.0X ~ 8.0X (depends on image size)		
LCD Display	2.4" Color LTPS LCD			
Focusing	Type	Auto Focus, Face Recognition AF		
	Range	Macro: 5cm~40cm (Wide only) Normal: 40cm ~ infinity		
Shutter	Type	Mechanical and Electrical Shutter		
	Speed	Normal: 1/2 sec. – 1/2000 sec., Night Scene: 4 sec. - 1/2000 sec.		
Exposure	Control	Programmed AE		
	ISO Equivalent	Auto, 100, 200, 400, 800		
Flash	Modes	Auto, Auto & Red Eye Reduction, SlowSync, Fill-in Flash, Flash Off		
Effect	Normal, Sepia, Negative, B&W			
White Balance	Auto, Daylight, Cloudy, Fluorescent, Tungsten, Sunset, Custom			
Voice Recording	Voice Recording (depends on capacity) Voice Memo in Still Image (max. 10 sec.)			
Date Imprinting	Date, Date & Time, Off (user selectable)			
Shooting	Still Image	Mode	Single Image, Continuous Shooting	
		Image Size	[8M]: 3264 X 2448 pixels [5M]: 2592 X 1944 pixels [3M]: 2048 X 1536 pixels [1M]: 1280 X 960 pixels	
		Image Quality	Super Fine, Fine, Normal	
	Self-Timer	10 sec. , 2 sec., Double, with LED indicator		
	Red-Eye Removal	Supported		
	Face Detection	Automatically finds faces and optimizes focus, AWB and exposure.		
	Scene Mode	Auto, Program, Portrait, Landscape, Night Portrait, Night Landscape, Sunset, Backlight, Fireworks, Candle-light, Beach, Auction		
	Movie Clip	Movie Size	720 x 480 (D1), 640 x 480 (VGA), 320 x 240 (QVGA)	
		Frame Rate	30fps	
	Photo Frame	9 frame options		
Storage	Media	Internal memory: 32M External memory: supporting SD card (up to 4G, SDHC supported)		
	File Format	Still Image	JPEG (DCF), EXIF 2.2, DPOF 1.1, PictBridge 1.0	
		Movie Clip	AVI, (Motion JPEG format)	
		Audio	Audio for Voice Recording and Memo: WAV	

Interface		Digital output connector: USB 2.0 (High Speed) Other interface: MIC-in,
Power Source		2 x AA alkaline, Ni-MH Battery
Dimensions (WxHxD)		91.7 x 30 x 61.5 mm
Weight		Approx. 120g (without battery and card)
Software	Camera Driver	Windows 2000/ME/XP, Vista32/64
	Application	Arcsoft MediaImpression

13. Customer care

Customer care

More information on the complete AgfaPhoto digital camera product range can be found under www.plawa.com / www.plawausa.com

Service & Repair (USA/ Canada):

1-866 475 2605

www.plawausa.com

Support Service (USA/ Canada)

Support-apdc@plawausa.com

Service & Repair Hotline (EU):

00800 752 921 00 (from a landline only)

Service & Support Hotline (Germany):

0900 1000 042 (1.49 Euro/ min. from a German landline only)

Online Service / International contact (Not for USA/ Canada):

support-apdc@plawa.com

Manufactured by

plawa-feinwerktechnik GmbH & Co. KG

Bleichereistraße 18

73066 Uhingen

Germany

AgfaPhoto is used under license of Agfa-Gevaert NV & Co. KG. Agfa-Gevaert NV & Co. KG. does not manufacture this product or provide any product warranty or support.

For service, support and warranty information, contact the distributor or manufacturer.

Contact: AgfaPhoto Holding GmbH, www.agfaphoto.com

Disposal of Waste Equipment by Users in Private Households in the European Union



This symbol on the product or on its packaging indicates that this product must not be disposed of with your other household waste. Instead, it is your responsibility to dispose of your waste equipment by handing it over to a designated collection point for the recycling of waste electrical and electronic equipment. The separate collection and recycling of your waste equipment at the time of disposal will help to conserve natural resources and ensure that it is recycled in a manner that protects human health and the environment. For more information about where you can drop off your waste equipment for recycling, please contact your local city office, your household waste disposal service or the shop where you purchased the product.

FCC Compliance and Advisory

This device complies with Part 15 of the FCC Rules. Operation is subject to the following two conditions: 1.) this device may not cause harmful interference, and 2.) this device must accept any interference received, including interference that may cause unsatisfactory operation. This equipment has been tested and found to comply with the limits for a Class B peripheral, pursuant to Part 15 of the FCC Rules. These limits are designed to provide reasonable protection against harmful interference in a residential installation. This equipment generates, uses, and can radiate radio frequency energy and, if not installed and used in accordance with the instructions, may cause harmful interference to radio communication. However, there is no guarantee that interference will not occur in a particular installation. If this equipment does cause harmful interference to radio or television reception, which can be determined by turning the equipment off and on, the user is encouraged to try to correct the interference by one or more of the following measures.

- Reorient or relocate the receiving antenna.
- Increase the separation between the equipment and receiver.
- Connect the equipment to an outlet on a circuit different from that to which the receiver is connected.
- Consult the dealer or an experienced radio/TV technician for help.

Any changes or modifications not expressly approved by the party responsible for compliance could void the user's authority to operate the equipment. When shielded interface cables have been provided with the product or when specified additional components or accessories have elsewhere been designated to be used with the installation of the product, they must be used in order to ensure compliance with FCC regulations.

AgfaPhoto is used under license of Agfa-Gevaert NV & Co. KG. Agfa-Gevaert NV & Co. KG does not manufacture this product or provide any product warranty or support. For service, support and warranty information, contact the distributor or manufacturer. All other brands and product names are registered trademarks of their respective owners. Product design and technical features can be changed without notice.

AgfaPhoto Holding GmbH, www.agfaphoto.com
Manufactured by plawa-feinwerktechnik GmbH & Co. KG, www.plawa.com