

# User Manual



## Digital Still Camera



A Series    A950 / A1050 / A1250 / WM1050  
              / A1035 / A1235

E Series    E1255W

GETTING READY

BASIC OPERATION

USING THE MODES

PLAYBACK

USING THE MENU

CONNECTIONS

APPENDICES



# WARNING

To prevent fire or shock hazard, do not expose the unit to rain or moisture.

**For customers in the U.S.A.**

## **Tested To Comply With FCC Standards FOR HOME OR OFFICE USE**

### **FCC Statement**

This device complies with part 15 of the FCC Rules. Operation is subject to the following two conditions:

- (1) This device may not cause harmful interference, and
- (2) this device must accept any interference received, including interference that may cause undesired operation.

**For customers in Europe**



"CE" mark indicates that this product complies with the European requirements for safety, health, environment and customer protection. "CE" mark cameras are intended for sales in Europe.



This symbol [crossed-out wheeled bin WEEE Annex IV] indicates separate collection of waste electrical and electronic equipment in the EU countries.

Please do not throw the equipment into the domestic refuse. Please use the return and collection systems available in your country for the disposal of this product.

### **Declaration of Conformity**

Model Name : A950/A1050/A1250/A1035/A1235/  
WM1050/E1255W

Trade Name : GE

Responsible Party : General Imaging Co.

Address : 2158 W.190th Street, Torrance, CA 90504, USA

Telephone Number : 1-800-730-6597

Conforms to the following Standards:

EMC : EN 55022:1998/A1:2000/A2:2003 Class B  
EN 55024:1998/A1:2001/A2:2003  
EN 61000-3-2:2000/A1:2001  
EN 61000-3-3:1995/A1:2001

following the provision of the EMC Directive (89/336/  
EEC,2004/108/EEC)

# SAFETY PRECAUTIONS

## Camera notes:

- ⚠** Do not store or use the camera in the following types of locations:
  - In the rain, very humid and dusty places.
  - In a place where the camera can be exposed directly to the sunlight or subject to high temperature, e.g. Inside a closed car in summer.
  - In a place where the camera is subject to a high magnetic field, e.g. near motors, transformers or magnets.
- ⚠** Do not place the camera on a wet surface or places where dripping water or sand may come in contact with the camera, which may cause irreparable faults.
- ⚠** If the camera will not be used for a long period of time, we suggest you remove the battery and the memory card.
- ⚠** If you carry the camera suddenly from a cold location to a warm place, moisture may condense inside the camera. We suggest you wait for a while before turning on the camera.
- ⚠** No compensation for loss of recordings. Loss of recordings cannot be compensated for if a malfunction of your camera or recording media, etc, makes the playback of recordings not possible.

## Battery notes:

- ⚠** Incorrect use of the batteries may cause them to leak, become hot, ignite or burst. Always observe the precautions given below.
  - Do not expose the batteries to water, and take particular care to keep the terminals dry.
  - Do not heat the batteries or throw them into a fire.
  - Do not attempt to deform, disassemble or modify the batteries.
  - Use GE charger in the package to charge the lithium battery only (for G and E series).
- ⚠** Keep the batteries out of reach of babies and small children.
- ⚠** In cold locations, battery performance deteriorates and the time for which they can be used shortens markedly.

## Memory card notes:

- ⚠** When using a new memory card, or a memory card has been initialized by a PC, be sure to format the card with your digital camera before using it.
- ⚠** To edit image data, copy the image data to the PC's hard disk and then format memory card if upgrade the firmware.
- ⚠** Do not change or delete the directory names, or file names in the memory card from your PC, as this may make it impossible to use the card in your camera.

# BEFORE YOU START

## Preface

Thank you for purchasing GE digital cameras. Please read this manual carefully and keep it in a safe place for future reference.

## Copyright

© Copyright 2009 General Imaging Company All rights reserved.

No part of this publication may be reproduced, transmitted, transcribed, stored in a retrieval system, or translated into any language or computer language, in any form, by any means, without the prior written permission of General Imaging Company.

## Trademarks

All trademarks mentioned in this manual are used for identification purposes only and may be properties of their respective owners.

## Safety information

Please read the following important information carefully before using the product.

- Do not take apart or attempt to service the camera yourself.
- Do not drop or knock the camera. Improper handling may damage the product.
- Turn off the camera before inserting or removing the battery and memory card.
- Use only the type of battery and charger that came with your camera. Using other types of batteries or chargers may damage the camera and invalidate the warranty.
- When using Li-ion batteries in this product, ensure that they are inserted correctly. Inserting the batteries upside down can cause damage to the camera and possibly start a fire.
- Do not touch the camera lens.

- Do not expose the camera to moisture, or extreme temperatures. Extreme environments may shorten the life of your camera or damage the batteries.
- Do not use or store the camera in dusty, dirty, or sandy areas, as its components may be damaged.
- Do not expose the lens to direct sunlight for extended periods.
- Download all pictures and remove the batteries from the camera if you are going to store the camera for long periods.
- Do not use abrasive cleansers, alcohol-based, or solvent-based cleaners to clean the camera. Wipe the camera with a slightly damp soft cloth.

## About this manual

This manual provides you with instructions on how to use your GE digital camera. Every effort has been made to ensure that the contents of this manual are accurate, but General Imaging Company reserves the right to make changes without notice.

## Symbols used in this manual

Throughout this manual, the following symbols are used to help you locate information quickly and easily.



Indicates the useful information to know.



Indicates the precautions to be taken while operating the camera.

# CONTENTS

## WARNING

## SAFETY PRECAUTIONS

### BEFORE YOU START ..... 1

Preface.....1

Copyright.....1

Trademarks.....1

Safety information.....1

About this manual.....2

Symbols used in this manual .....2

### CONTENTS..... 3

### GETTING READY ..... 7

Unpacking.....7

Camera Views : A Series.....8

: E Series..... 10

Charging the battery..... 12

Inserting the battery ..... 13

Inserting an optional SD/SDHC card..... 16

Turning on and off..... 17

Using the Mode Dial..... 18

Setting date/time and language ..... 19

Setting the Date and Time..... 19

Setting the Language ..... 20

About the LCD screen ..... 21

### BASIC OPERATION ..... 22

Shooting in Auto mode..... 22

Using the zoom function..... 22

Using the flash ..... 23

Using the self-timer/Multiple shots ..... 23

Using Macro mode ..... 24

Exposure compensation ..... 24

Advanced function menu (quick menu setup)..... 25

WB (White Balance)..... 25

ISO ..... 26

|                                   |           |  |    |
|-----------------------------------|-----------|--|----|
| Quality.....                      | 27        | Sport .....                            | 38 |
| Size.....                         | 28        | Children.....                          | 38 |
| Color .....                       | 29        | Indoor .....                           | 38 |
| <b>USING THE MODES .....</b>      | <b>32</b> | Leaf .....                             | 38 |
| LCD Screen display.....           | 32        | Snow .....                             | 38 |
| Still shooting mode display ..... | 32        | Sunset.....                            | 39 |
| Video shooting mode display.....  | 34        | Fireworks.....                         | 39 |
| Playback mode display.....        | 35        | Glass .....                            | 39 |
| Auto Scene mode (ASCN).....       | 36        | Museum .....                           | 39 |
| Landscape Mode.....               | 37        | Landscape .....                        | 39 |
| Portrait mode .....               | 37        | Night landscape.....                   | 39 |
| Night Portrait .....              | 37        | Night portrait .....                   | 39 |
| Backlit Portrait.....             | 37        | Return to the scene mode palette ..... | 40 |
| Night Landscape Mode.....         | 37        | Pan-Capture Panorama.....              | 40 |
| Macro Mode .....                  | 37        | Image Stabilization mode.....          | 42 |
| Auto Mode .....                   | 37        | Face Detection .....                   | 44 |
| Scene mode (SCN).....             | 38        | Smile Detection.....                   | 45 |
|                                   |           | Blink Detection.....                   | 46 |



|  |           |   |           |
|--|-----------|---|-----------|
| <b>PLAYBACK .....</b>                              | <b>47</b> | <b>Slow Shutter.....</b>                | <b>57</b> |
| Viewing photos and videos .....                    | 47        | Blink Detection.....                    | 58        |
| Editing video .....                                | 49        | Date Imprint.....                       | 58        |
| Thumbnail view.....                                | 50        | Movie menu .....                        | 59        |
| Using zoom playback (for still pictures only)..... | 51        | Expo Metering (Exposure Metering).....  | 60        |
| Using the Delete button.....                       | 52        | Playback menu.....                      | 61        |
| <br>   |           | Protect.....                            | 61        |
| <b>USING THE MENUS .....</b>                       | <b>53</b> | Delete .....                            | 62        |
| Still menu .....                                   | 53        | DPOF (Digital Print Order Format) ..... | 63        |
| AF mode (Auto-Focus mode).....                     | 54        | Info. Box (Information Box) .....       | 64        |
| AF-assist beam.....                                | 54        | Trim.....                               | 64        |
| Expo Metering (Exposure Metering).....             | 54        | Resize.....                             | 65        |
| Cont.Shot (Continuous shot).....                   | 55        | Rotate.....                             | 65        |
| Grid .....   | 55        | Slide show.....                         | 66        |
| Quick Review .....                                 | 56        | Red-eye removal.....                    | 67        |
| Digital Zoom.....                                  | 56        | Setup menu.....                         | 68        |
| Histogram.....                                     | 57        | Format Memory.....                      | 68        |

|  |           |   |           |
|--|-----------|---|-----------|
| Beep.....  | 69        | Connecting to a PictBridge compatible printer.... | 79        |
| LCD Brightness.....  | 69        | Setting the USB mode.....                         | 79        |
| Power Saver.....   | 70        | Connecting the camera and printer.....            | 80        |
| Date/Time.....   | 71        | Using the PictBridge menu.....                    | 81        |
| World time.....  | 71        | Print with date.....                              | 81        |
| File Numbering.....  | 71        | Print without date.....                           | 82        |
| Language.....  | 72        | Print index.....                                  | 83        |
| Video system.....  | 72        | Print DPOF.....                                   | 84        |
| Copy to Card (Copy internal<br>memory to memory card)..... | 73        | Exit.....   | 84        |
| Reset Settings.....  | 73        | <b>APPENDICES .....</b>                           | <b>85</b> |
| FW Ver. (Firmware version).....                            | 74        | Specifications:                                   |           |
| <b>CONNECTIONS .....</b>                                   | <b>75</b> | A950/A1050/WM1050/A1250.....                      | 85        |
| Connecting to a TV.....                                    | 75        | A1035/A1235.....                                  | 90        |
| Connecting to a PC.....                                    | 76        | E1255W.....                                       | 94        |
| Setting the USB mode.....                                  | 76        | Error messages.....                               | 98        |
| Transferring files to your PC.....                         | 76        | Troubleshooting.....                              | 100       |

# GETTING READY

## Unpacking

Your package should contain the camera model you purchased along with the following items. If anything is missing or appears to be damaged, please contact your vendor. The accessories will vary based on model purchased and are noted below.



Rechargeable  
Lithium-ion battery  
(except A Series)

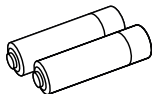

AA-size alkaline  
batteries X2 (A  
Series only)



User Manual



Quick start guide



Wrist strap

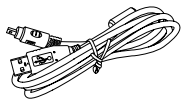

USB cable

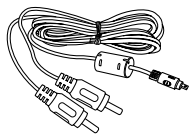

AV cable

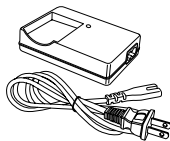

Battery charger  
(except A Series)

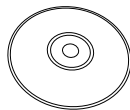

CD-ROM



Warranty card

## Camera views : A Series

Front View

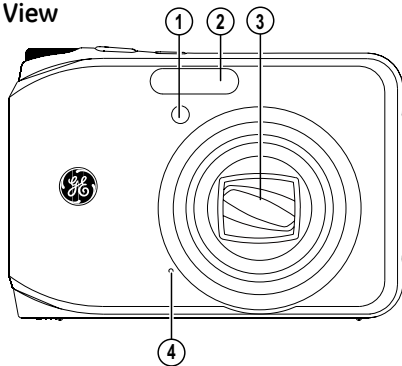

Back View

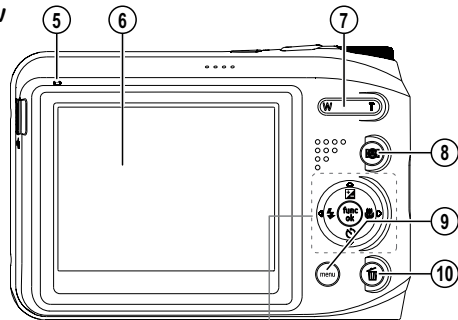

Right View

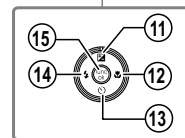
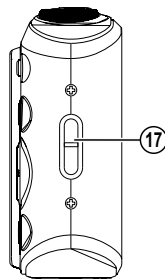

## Top View

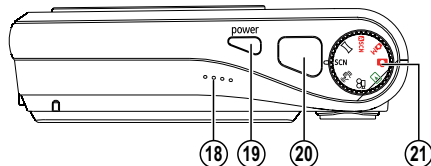

## Bottom View

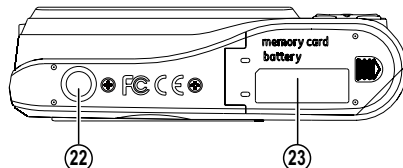

## Left View

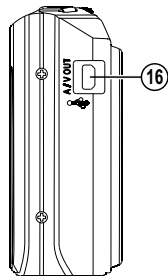

|    |                                   |    |                                   |
|----|-----------------------------------|----|-----------------------------------|
| 1  | AF assist beam / Timer indicator  | 13 | Self-timer / Down button          |
| 2  | Flash                             | 14 | Flash mode / Left button          |
| 3  | Lens                              | 15 | Func / ok button                  |
| 4  | Mic                               | 16 | USB/ AV port                      |
| 5  | Status LED                        | 17 | Wrist strap mount                 |
| 6  | LCD screen                        | 18 | Speaker                           |
| 7  | Zoom scroll wheel                 | 19 | Power button                      |
| 8  | Face detection AF button          | 20 | Shutter button                    |
| 9  | Menu button                       | 21 | Mode dial                         |
| 10 | Erase button                      | 22 | Tripod mount point                |
| 11 | Exposure compensation / Up button | 23 | Memory card / Battery compartment |
| 12 | Macro mode/ Right button          |    |                                   |

## Camera views : E Series

Front View

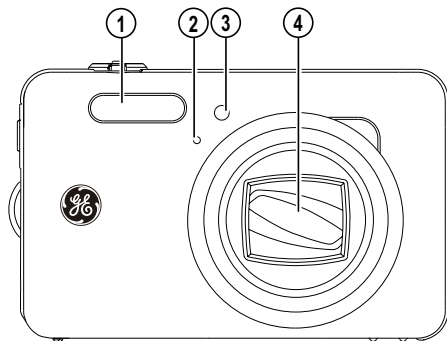

Back View

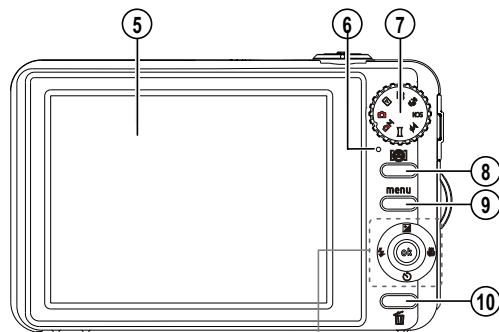

Right View

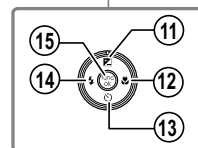
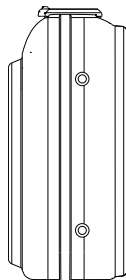

## Top View

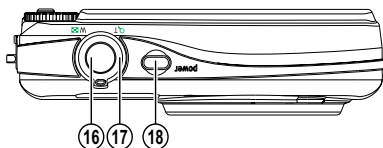

## Bottom View

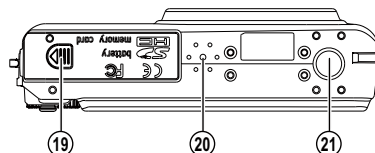

## Left View

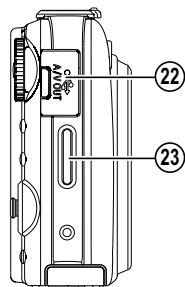

|    |                                   |    |                                   |
|----|-----------------------------------|----|-----------------------------------|
| 1  | Flash                             | 13 | Self-timer / Down button          |
| 2  | Mic                               | 14 | Flash mode / Left button          |
| 3  | AF assist beam / Timer indicator  | 15 | Func / ok button                  |
| 4  | Lens                              | 16 | Shutter button                    |
| 5  | LCD screen                        | 17 | Zoom scroll wheel                 |
| 6  | Status LED                        | 18 | Power button                      |
| 7  | Mode dial                         | 19 | Memory card / Battery compartment |
| 8  | Face detection AF button          | 20 | Speaker                           |
| 9  | Menu button                       | 21 | Tripod mount point                |
| 10 | Erase button                      | 22 | USB / AV port                     |
| 11 | Exposure compensation / Up button | 23 | Wrist strap mount                 |
| 12 | Macro mode / Right button         |    |                                   |

## Charging the battery (except A Series)

1. Place the battery into the charger as shown.
2. Plug one end of the connecting cable into the charger base.
3. Plug the other end of the connecting cable into a wall outlet.



Throughout the rest of the manual, the following illustrations show the A1050 model as an example. The A950, A1250, A1035, A1235, WM1050, E1255W models operate similarly.)

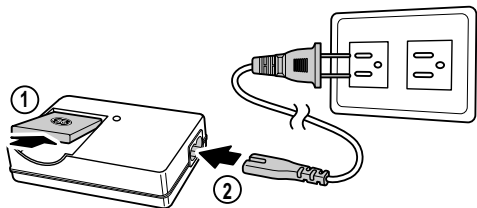

Leave the battery to charge until the charger light goes green.

(To maximize battery life, the first charge should be at least 4 hours)



## Inserting the battery

1. Open the battery compartment.

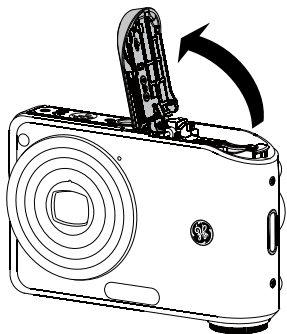
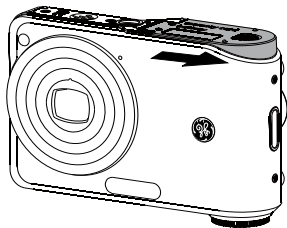

2. Insert the battery while observing the correct polarity. Use the side of battery to press down the stopper as shown, allowing the battery to be inserted properly.

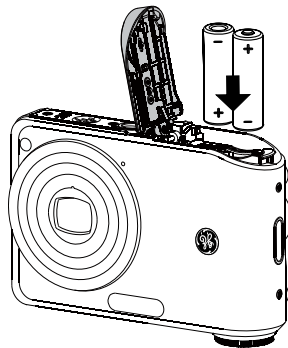

3. Close the battery compartment.

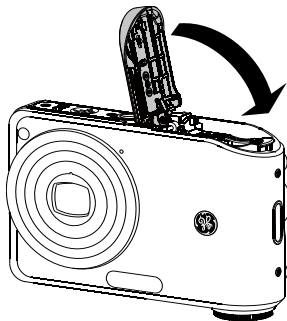

## Inserting the battery (E Series)

1. Open the battery compartment.

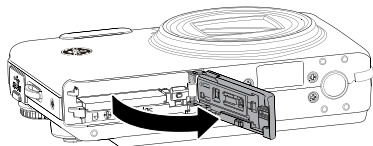
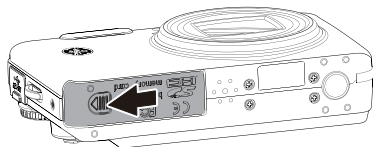

2. Insert the battery while observing the correct polarity. Use the side of battery to press down the stopper as shown, allowing the battery to be inserted properly.

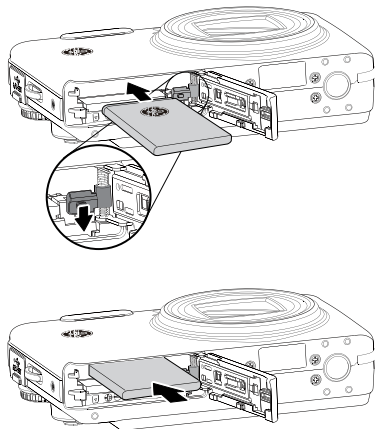

3. Close the battery compartment.

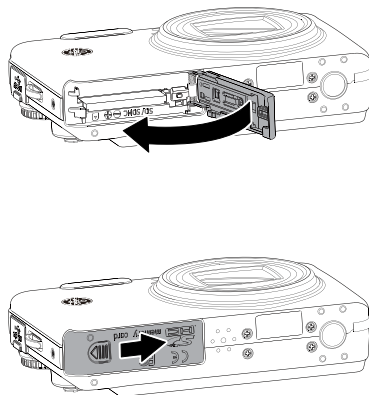

Battery capacity decreases with usage.

## Inserting an optional SD/SDHC card

1. Open the battery compartment.

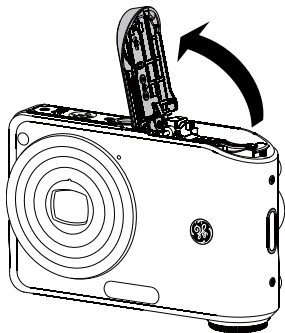
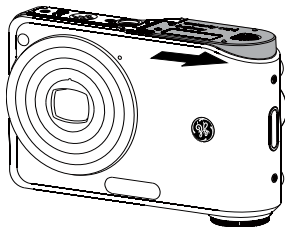

2. Insert an optional SD/SDHC card into the memory card slot as shown.

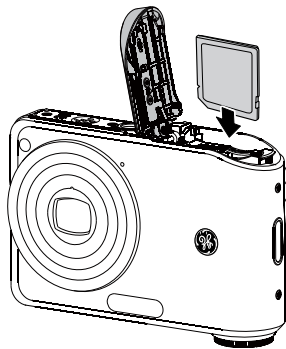

Optional SD/SDHC cards are not included. The use of 64MB to 8GB memory cards from recognized manufacturers such as SanDisk, Panasonic and Toshiba is recommended for reliable data storage.

3. Close the battery compartment.

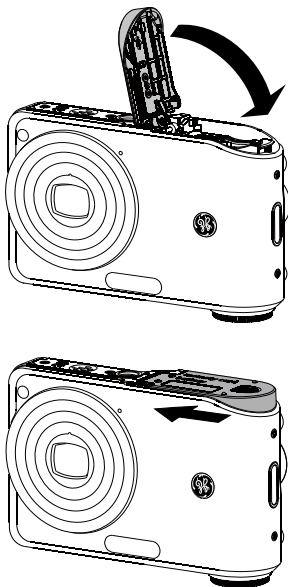

To remove the SD/SDHC card, open the battery compartment and gently push the card to release it. Pull the card carefully.

## Turning on and off



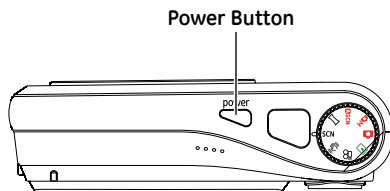



Press the **Power** button to turn the camera on. To turn off the camera, press the **Power** button again.



When turned on, the camera will enter the mode according to the mode dial setting. You can also turn the mode dial to change the modes after the camera is turned on.

## Using the Mode Dial

The GE camera provides a convenient mode dial that allows you to switch between different modes with ease. All the available modes are listed as follows.

| Mode Name           | Icon  | Description  |
|---------------------|---|--|
| Auto                |  | Switch to take still pictures. (The camera uses the default programmed automatic settings.)  |
| Playback            |  | Switch to view the pictures/videos stored in the memory card and internal memory.  |
| Movie               |  | Switch to record videos.   |
| Image Stabilization |  | Switch to use Image Stabilization when taking still pictures.  |
| Scene               | SCN   | Switch to use a preset scene mode for taking still pictures. There are 12 scenes in total.   |
| Auto Scene          |  | In the "ASCN" mode, different conditions are detected intelligently and the most suitable settings will be automatically selected. |
| Panorama            |  | Switch to capture a sequence of shots and stitch them together into a panoramic photo.   |
| Manual              |  | Switch to take still pictures in manual mode, where many camera settings can be configured. (Recommended for advanced users only)  |

## Setting date/time and language

To set the language, date, and time, the following settings need to be configured in the **Setup** menu.

- Date / Time
- Display language

To access the **Setup** menu, do the following:

1. Press **Power** to turn the camera on.
2. Press the  button and use **Up/Down/Left/Right** to select the **Setup** menu.

### Setting the Date and Time

1. Use the **Up/Down** to select **Date/Time**. Then press the **Right** to enter the setting.

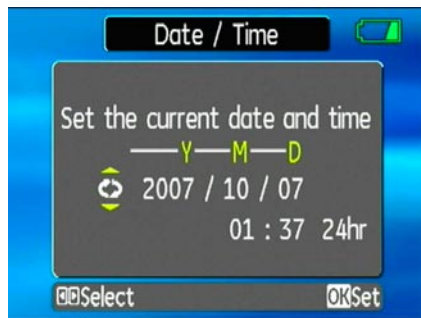



2. Press the **Left/Right** to highlight each field and use the **Up/Down** to adjust the value.
3. Press the  button to confirm the setting.

## Setting the Language

1. Use the **Up/Down** to select **Language**. Then press the **Right** to enter the setting.



2. Use the navigation buttons to select the desired language.
3. Press the  button to confirm the setting.

 The Set date/time and language screen will automatically appear when the camera is turned on the first time.



## About the LCD screen

When you turn the camera on, various icons are shown on the LCD screen to indicate the current camera settings and status. To learn more about the displayed icons, see “LCD Screen display” on page 32.

### LCD Screen notes:

Extremely high-precision technology had been used to manufacture the LCD screen so that most of the pixels are operational for use. However, there may be some minute points (black, white, red, blue or green) that constantly appear on the LCD screen. These points are normal in the manufacturing process and the recording is not affected in any way.



If the LCD monitor is damaged, take particular care with the liquid crystal in the monitor. If any of the following situations arise, take the urgent action indicated.

- If liquid crystal comes in contact with your skin, wipe the area with a cloth and then wash thoroughly with soap and running water.
- If liquid crystal gets into your eye, flush the affected eye with clean water for at least 15 minutes and then seek medical assistance.
- If liquid crystal is swallowed, flush your mouth thoroughly with water. Drink large quantities of water and induce vomiting. Then seek medical assistance.

# BASIC OPERATION

## Shooting in Auto mode

**Auto mode** is the easiest mode to take photos. While operating in this mode, the camera automatically optimizes your photos for best results.

To start shooting, do the following:

1. Set the mode dial to **Auto mode** (  ).
2. Press **Power** to turn the camera on.
3. Compose your picture on the LCD screen and press the shutter button halfway to focus on the subject.
4. When the subject is in focus, the green colored focus frame appears on the center of the LCD screen.
5. Press **Shutter** fully to capture the image.

## Using the zoom function

Your camera is equipped with two types of zoom: optical zoom and digital zoom. Press the **Zoom button** on either the **Wide** or **Tele** position of the camera to zoom in or out on your subject while taking pictures.

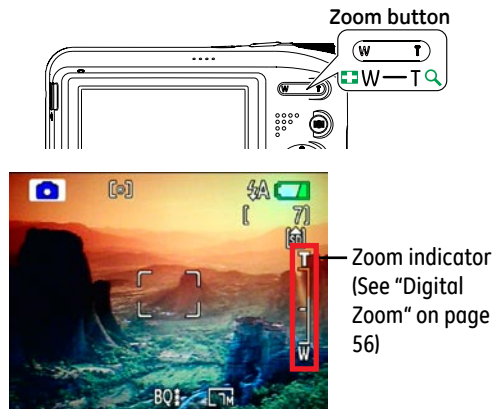

When the optical zoom factor reaches its maximum value, it stops momentarily. Keep pressing down the **Tele** position (  ) and the zoom will switch over to digital zoom automatically.

## Using the flash

There are six flash modes. Press the **Left/Flash** to cycle through the following flash modes.

- Auto flash  
Camera flash fires automatically based on existing light conditions.
- Red-eye reduction flash  
The camera fires a brief flash before the picture is taken to reduce red-eye effects.
- Forced flash  
Flash always fires.
- Flash off  
Flash is turned off.
- Slow Synchro  
This allows you to take pictures of people at night that clearly show both your subjects and the night time backdrop.
- Red-Eye Reduction+Slow Synchro  
Use this mode for slow synchro shots with red-eye reduction.

## Using the self-timer/Multiple shots

To enable the self-timer function, press the **Down/Self-timer** to select 2-second timer delay, 10-second timer delay, or a continuous shot.

- 2-second timer delay  
A single picture is shot 2 seconds after the shutter button is pressed.
- 10-second timer delay  
A single picture is shot 10 seconds after the shutter button is pressed.
- Continuous shot  
Pictures are shot continuously when the shutter button is pressed based on the Continuous Shot settings in the menu. (See “Continuous Shot” on page 55).

## Using Macro mode

In **Macro** mode, you can capture tiny details of the subject at a very close range. Press the **Right/Macro** to take close-up shots.



Macro

Select this to focus on subjects 5cm from the lens.

## Exposure compensation

The exposure compensation allows you to adjust the background brightness to produce the best result of photos. To change the exposure values, do the following:

1. When taking a picture, press the Up/Exposure button to activate the set exposure screen.



2. Use the **Left/Right** to adjust the exposure value for the picture. The range is from EV -2.0 to EV+2.0 (steps of 0.3).

## Advanced function menu (quick menu setup)

### WB (White Balance)







The white balance allows the user to adjust the color temperature under different light source to ensure faithful color reproduction.

(The WB setting is only available when the camera is in the **M Manual** mode).

To set the white balance, do the following:

1. Press the  button to enter the **Function** menu. Make sure the **WB** function is selected.



2. Use **Up/Down** navigation buttons to select the setting you want. The following options are available:
  - **AUTO** Auto
  -  Daylight
  -  Cloudy
  -  Fluorescent
  -  Fluorescent CWF
  -  Incandescent
  -  Manual WB adjustment (press the menu button to set)
3. Use the **Left/Right** buttons to select other options, or press the  button once to confirm your selection and exit the current menu.

## ISO

The ISO function allows you to set the camera sensor sensitivity to light. To improve the performance in darker environments, a higher ISO value is required. On the other hand, a lower ISO value is needed when in bright conditions.

(The ISO setting is only available when the camera is in the **M Manual mode**).



To set the ISO value, do the following:

1. Press the  button to enter the **Function** menu.
2. Use the **Left/Right** navigation buttons to highlight the **ISO** function.



Higher ISO pictures will naturally have more noise than lower ISO pictures.



3. Use the **Up/Down** navigation buttons to select the desired ISO value from **Auto, 64, 80, 100, 200, 400, 800, or 1600**.
4. Press the  button to confirm your setting.
5. Use the **Left/Right** buttons to select other options, or press the  button once to confirm your selection and exit the current menu.

## Quality





The quality setting adjusts the compression ratio of the images. Higher quality settings give better photos, but will take up more memory space.

To set the image quality, do the following:

1. Press the  button to enter the **Function** menu.
2. Use the **Left/Right** navigation buttons to highlight the **Quality** function.



3. Use the **Up/Down** navigation buttons to select a desired setting. Three options are available.

-  : Best quality (Standard compression)
  -  : Fine quality (High compression)
  -  : Normal quality (Maximum compression)
4. Press the  button to confirm your setting.
  5. The number of available shots remaining is displayed on the LCD.
  6. Use the **Left/Right** buttons to select other options, or press the  button once to confirm your selection and exit the current menu.

## Size

The size setting refers to the image resolution in pixels. A higher image resolution allows you to print that image in larger sizes without degrading the image.

To set the image size, do the following:

1. Press the  button to enter the **Function** menu.
2. Use the **Left/Right** navigation buttons to highlight the **Size** function.



3. Use the **Up/Down** navigation buttons to select a resolution.
4. Press the  button to confirm your setting.

5. The number of available shots is displayed on the screen.

 The bigger the number of recorded pixels is, the better the image quality becomes. As the number of recorded pixels becomes smaller, you will be able to record more frames on a memory card.

 Please refer to page 30 for a list of image sizes that are available to the various GE digital camera models.



## Color

The color setting allows you to add artistic effects directly when taking shots. You can try different color tones to alter the mood of your pictures.

(The Color setting is only available when the camera is in the **Ⓜ Manual** mode).

To set the image color, do the following:

1. Press the **func ok** button to enter the **Function** menu.
2. Use the **Left/Right** navigation buttons to highlight the **Color** function.



3. Use **Up/Down** to select an option. The following options are available:

- **Off** Auto
- **SE** Black & White
- **SE** Sepia
- **UV** Vivid

4. Press the **func ok** button to confirm your setting.

• Size settings in shooting mode. (•: available)

| File size (Pixels)     | Model name : |       |       |       |       |        |        |
|------------------------|--------------|-------|-------|-------|-------|--------|--------|
|                        | A950         | A1050 | A1250 | A1035 | A1235 | WM1050 | E1255W |
| 0.3M:<br>640×480       | •            | •     | •     | •     | •     | •      | •      |
| 2M:<br>1600×1200       |              |       |       |       |       |        | •      |
| 3M:<br>2048×1536       | •            | •     | •     | •     | •     | •      | •      |
| 5M:<br>2560×1920       | •            | •     | •     | •     | •     | •      | •      |
| 7M(16:9):<br>3456×1944 | •            | •     |       | •     |       | •      |        |
| 8M:<br>3264×2448       | •            | •     | •     | •     | •     | •      | •      |
| 8M(3:2):<br>3456×2304  | •            |       |       |       |       |        |        |
| 8M(16:9):<br>3842×2152 |              |       |       |       |       |        |        |

| File size (Pixels)       | Model name : |       |       |       |       |        |        |
|--------------------------|--------------|-------|-------|-------|-------|--------|--------|
|                          | A950         | A1050 | A1250 | A1035 | A1235 | WM1050 | E1255W |
| 9M:<br>3456×2584         | •            | •     |       | •     |       | •      |        |
| 9M(3:2):<br>3648×2432    |              | •     |       | •     |       | •      |        |
| 9M(16:9):<br>4000×2248   |              |       | •     |       | •     |        | •      |
| 10M:<br>3648×2736        |              | •     | •     | •     | •     | •      | •      |
| 10M(3:2):<br>3824×2548   |              |       | •     |       | •     |        |        |
| 10.5M(3:2):<br>4000×2672 |              |       |       |       |       |        | •      |
| 11M:<br>3824×2868        |              |       |       |       |       |        |        |
| 12M:<br>4000×3000        |              |       | •     |       | •     |        | •      |

# USING THE MODES

## LCD Screen display

### Still shooting mode display

Mode: SCN SCN

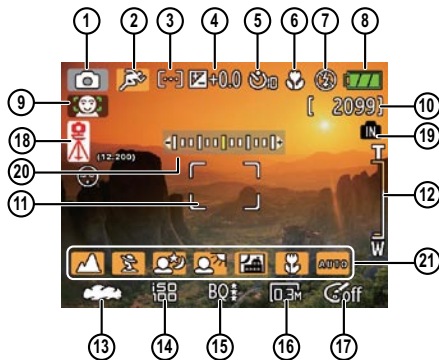

#### 1. Shooting mode icon



#### 2. Scene icon (only available for Scene mode)





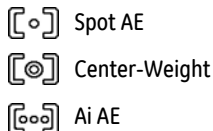



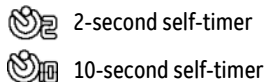

#### 3. Light metering method



#### 4. EV indicator

#### 5. Self-timer indicator



-  Continuous shot
- 6. Macro mode indicator
  -  Macro mode
- 7. Flash mode indicator
  -  Auto flash
  -  Red-eye reduction flash
  -  Forced flash
  -  Flash off
  -  Slow Synchro
  -  Red-Eye Reduction+Slow Synchro
- 8. Battery status
- 9. Face detection "on" indicator
- 10. Remaining number of photos that can be taken.
- 11. Focus frame
- 12. Zoom indicator
- 13. White balance (only available for **Manual mode**)
- 14. ISO (only available for **M Manual mode**)
- 15. Image quality
- 16. Image size
- 17. Image color (only available for **M Manual mode**)
- 18. Slow shutter warning indicator
- 19. Memory card/internal memory indicator
- 20. EV adjustment meter
- 21. Auto Scene mode icon

## Video shooting mode display

Mode: 

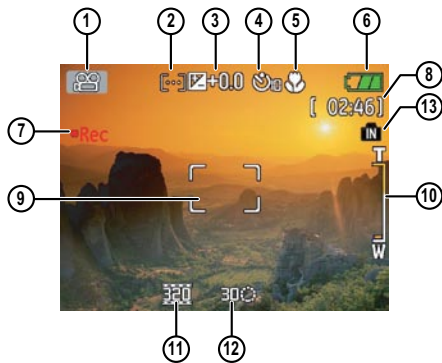



1. Shooting mode icon
2. Light metering method

 Spot AE

 Center-Weight

 Ai AE

3. EV indicator
4. Self-timer indicator  
 10-second self-timer
5. Macro mode indicator  
 Macro mode
6. Battery status
7. Movie recording "on" indicator
8. Remaining time for videos that can be taken.
9. Focus frame
10. Zoom indicator
11. Video resolution
12. Video quality
13. Memory card/built-in memory indicator

 For best movie results, the use of SD cards is recommended. Movie recordings using internal memory are subject to quality degradations.

 While movie recording is in progress, optical zoom will stay fixed, but up to 1.5X digital zoom will remain available.

## Playback mode display

Mode: 

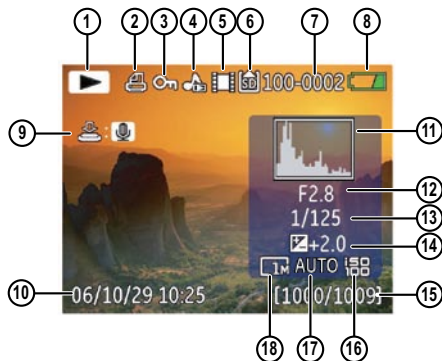

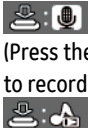
1. Playback mode icon
2. DPOF file icon
3. File protection icon
4. Audio file icon
5. Video file icon
6. Memory card/internal memory indicator
7. Picture ID
8. Battery status
9. Photo audio status  
  
(Press the shutter button to record sound)  
(Press the shutter button to play sound)
10. Recording date and time
11. Histogram
12. Aperture value
13. Shutter speed
14. Exposure value
15. Memory capacity (current picture/total picture number)
16. ISO value
17. WB
18. Image size

## Auto Scene mode (ASCN)

In the "ASCN" mode, different conditions are detected intelligently and the most suitable settings will be automatically selected. With "ASCN" you can always take good pictures.

Follow these steps to create a "ASCN":

1. Turn the mode dial to "ASCN", LCD display showing the following diagram.
2. Hold the camera steady and aim at the subject. At this time, an appropriate mode will be selected to suit the lighting conditions of the scene you are photographing.
3. Press the shutter button halfway down to focus.
4. Press the shutter button all the way down to take the picture.



| Icon | Mode name        | Icon | Mode name            |
|------|------------------|------|----------------------|
|      | Landscape Mode   |      | Night Landscape Mode |
|      | Portrait mode    |      | Macro Mode           |
|      | Night Portrait   |      | Auto Mode            |
|      | Backlit Portrait |      |                      |



In the "ASCN" mode, different conditions are detected intelligently and the most suitable settings will be automatically selected.



## **Landscape Mode**

For landscapes, ASCN will automatically adjust the exposure to match the background.

## **Portrait mode**

For portraits, ASCN will automatically adjust the exposure and skin tones to give clear pictures.

## **Night Portrait**

When you shoot portraits at night, or in low light conditions, ASCN will automatically adjust the exposure for people and night scenes.

## **Backlit Portrait**

When the sun or any other light source is behind you, ASCN will automatically adjust the foreground exposure to produce good pictures.

## **Night Landscape Mode**

For night scenes, ASCN will automatically increase the ISO value to compensate for low light.

## **Macro Mode**

To capture object detail for close-ups, ASCN will automatically adjust the focus.

## **Auto Mode**

The camera automatically adjusts the exposure and focus to ensure good pictures.

## Manual Scene mode (SCN)

In **Manual Scene** mode, you can select from a total of 12 scene types to match your needs. You just need to select the right scene for the occasion and the camera will automatically adjust to the optimal settings for you.

To enter the scene mode, turn the mode dial to **Manual Scene** mode. The scene mode palette appears.



Use **Up/Down/Left/Right** to select a scene, and press the  button.

### **Sport**

For shooting fast-moving objects. Bring lively pictures to life.

### **Children**

Suitable for photographing children and pets. The flash shuts off automatically in order not to disturb the subject being photographed.

### **Indoor**

For shooting people indoors. Clearly show background and atmosphere.

### **Leaf**

For shooting plants. Vivid reproduction of green.

### **Snow**

Suitable for snowy landscape. Camera automatically adjusts and corrects exposure value (EV).

### **Sunset**

For shooting sunsets. Vivid reproduction of red and yellow.

### **Fireworks**

For shooting at night and fireworks. Shutter speed is slower than normal. (Use of tripod is recommended)

### **Glass**

Suitable for photographing objects behind glass or window.

### **Museum**

For shooting in museums or places where flash is not allowed.

### **Landscape**

For shooting landscapes. Vivid reproduction of green and blue.

### **Night landscape**



For shooting night scenes. Use of tripod is recommended.

### **Night portrait**

For shooting portraits with night scenes as background.

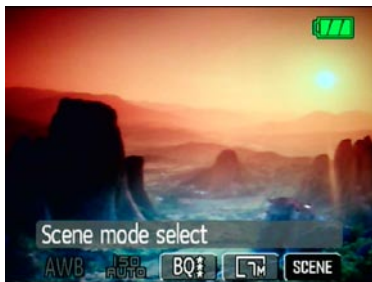
## Returning to the Scene selection menu



1. In **Scene mode**, press the  button to activate the main function menu.
2. Select the "SCENE" menu option and then press the  button to return to the Scene selection menu.

The main function menu also allows you configure image quality and image size. Please refer to the "**Advanced Functions Menu**" section on pages 25 for detailed instructions.

## Pan-Capture Panorama

Panorama mode allows you to create a panoramic picture. The camera will automatically compose a panoramic picture using the individual shots that you take.

Follow these steps to create a panoramic picture:

1. Turn the mode dial to the Panorama Stitching Mode. Then enter the Still menu to Select either Auto Stitching or Manual Stitching (Please refer to Page53 to enter the Still menu.)



2. Set the mode dial to **Panorama mode** ().

3. Use the **Left/Right** buttons to specify the direction of picture taking, and then in 2 seconds the panoramic sequence will commence automatically.
4. Compose your first view on the LCD screen and press the shutter button.
5. Use "Stitching Mode" selected from the Menu.

#### When Using Auto Stitching:

After the first shot is taken, the camera will make a calculation and two icons will appear on the LCD screen. Once they appear, move the camera and the circle icon on the screen will move with the scenery until it reaches the square frame icon. When circle icon and square frame become green, the camera will take pictures automatically and finish the stitching.







#### When Using Manual Stitching:

After the first shot is taken, the semi-transparent image of the first shot will appear at the edge of the screen. You can use this image to compose your picture before you press the shutter button to finish manual stitching.



6. The camera will then stitch the pictures into a panorama automatically.
7. Turn the mode dial to playback mode to view the panoramic picture.

- 
 While in panorama mode, press the  button to save images and exit panorama shooting. Press the  button to discard images and exit.
- 
 Flash mode, self-timer, macro mode, and exposure compensation cannot be adjusted after the first picture is taken.
- 
 Pictures cannot be deleted, nor the zoom adjusted until the series is finalized.





## Image Stabilization mode

The Image Stabilization mode combats the effect of hand shake and allows you to take pictures that would otherwise be blurred.





1. Switch the mode dial to (  ) mode.
2. Press **Shutter** halfway to focus on the subject.
3. Press **Shutter** fully to capture the image.

The stabilizer function is used for less blur picture caused by hand shake under a dark environment, the camera would increase the ISO level under the mode to have a higher shutter speed.

-  This function may not help to take a clear picture of a fast moving target, such as a car passing by, etc.
-  This function may not help to stabilize photos if you are in a moving vehicle (car, boat, etc.). It is best used when taking normal shots.
-  Increasing the ISO level may cause heavier noise on the photo.
-  Use of a tripod is always best to get the clearest picture.

## Face Detection

The Face Detection mode will detect faces of persons in a photo so that the faces will be as clear as possible.

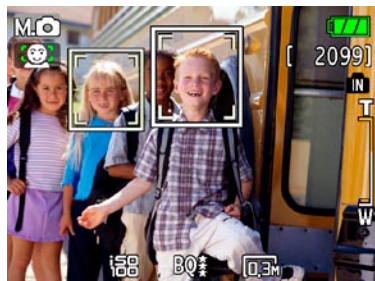

1. While in photography mode, press the  button to activate Face Detection. The  indicator appears on the LCD.
2. Hold the camera securely, and point the camera towards the subject to start the face detection process. When the camera detects a face, a white rectangular frame will be drawn around the face. (Note: For best results, the face of the subject should be relatively large on the LCD screen, and the subject should be facing the camera as front on as possible.)
3. Press **Shutter** halfway to focus on the subject.
4. Press **Shutter** fully to capture the image.
5. Press the  button again to deactivate face detection.





## Smile Detection

With the camera's new "smile detection" feature, which automatically detects and captures a person smiling, you'll never miss a smile.

1. While in shooting mode, press the  button repeatedly until  appears on the LCD. This icon indicates that the camera is in Smile Detection mode.
2. Point the camera at the subject until the subject's face is detected and bracketed by a square box. Press the shutter button all the way down and release the shutter button. The camera will now 'wait' for the subject to smile.
3. When the subject smiles, the camera will automatically release the shutter and capture the photo.
4. To disable the automatic shutter release, press the shutter again  .



### Note:

- A face must be detected by the camera in order for smile detection to function correctly.
- For optimal detection results, the subject should be framed to occupy most of the screen space.



## Blink Detection

The Blink Detection feature is on by default, and after taking each photo, a warning message will pop up if a blink had been detected in the photo.

1. In photography modes, press the button  to enter the Photo menu.
2. Use the Up/Down navigation buttons to select "Blink detection" setting.
3. Use the Right navigation buttons to enter the submenu, and select "On" option.
4. Press the button  to confirm the setting and exit the menu.
5. The "Blink detection" indicator appears on the LCD.
6. Press the shutter button fully to capture the image, if someone's eyes blink, the camera will automatically show blink detection warning message.

### Note:

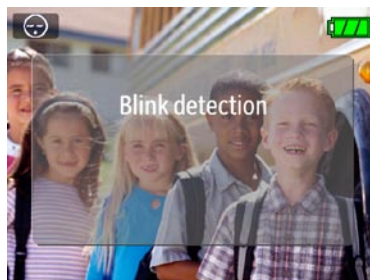

- For optimal results, the subject should be framed to occupy most of the screen space.



# PLAYBACK

## Viewing photos and videos

To view the captured photos and video clips on the LCD screen:

1. Turn your camera to **Playback** mode. The last recorded photo or video clip is displayed.
2. Use the **Left/Right** navigation buttons to scroll through the photos or video clips stored in the internal memory or memory card.
3. To play a selected video clip, press the  button to enter the movie playback mode.
4. Use the **Left/Right** navigation buttons to select a program button and press the  button to confirm the selection. The function of each button is described in the following.



- |   |             |   |                |
|---|-------------|---|----------------|
| 1 | Exit        | 5 | Previous frame |
| 2 | Play        | 6 | Next frame     |
| 3 | Slow motion | 7 | Edit Movie     |
| 4 | First frame |   |                |

During the video playback, an operation guide appears on the screen. You can use the navigation pad to perform the functions accordingly.



During the video playback, you can use the **Up/Down** navigation buttons to adjust the volume of playback.

During the slow motion playback, you can use the **Left/Right** navigation buttons to adjust the speed of playback.

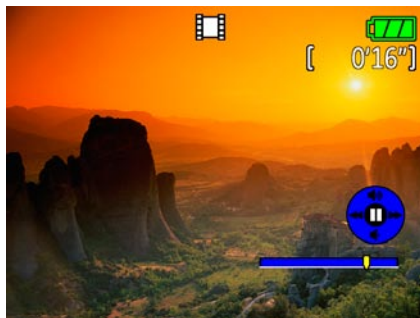



Volume will be muted when using the slow motion playback.

## Editing video

Press the **Edit**  program button to enter the following screen and use the buttons on the left side to edit the playback. Use the **Up/Down** navigation buttons to select a button.



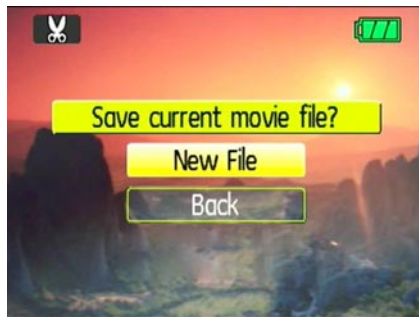

1. Select the **%/1st** button and use the **Left/Right** navigation buttons to specify the new beginning of the playback.
2. Select the **%2nd** button and use the **Left/Right** navigation buttons to specify the new end of the playback.

3. To save the file, select the  button and press the  button.
4. Use the **Up/Down** navigation buttons to select an option.



- **New file:** Save as a new file.
  - **Back:** Do not save the file and return to the Edit screen.
5. Press the  button to confirm your setting.

To exit the Edit screen, select the  button and press the  button.



 Edited video must be at least 1 second long .



 With sufficient battery and at least 1GB available memory, up to 30 minutes of footage can be recorded per movie.

## Thumbnail view

When in **Playback** mode, press down the Zoom button at the Wide position ( W) once to display the thumbnail of photos and video clips on the screen.

1. Use the Zoom button to switch between the 2x2, 3x3, and 4x4 thumbnail display.
2. Use **Up/Down/Left/Right** to select a photo or video clip to view.

 If the  indicator appears on the LCD, then a movie file is currently being displayed.

 Press the  button to restore a preview icon to its original image size.

## Using zoom playback (for still pictures only)

The zoom scroll wheel can also be used during playback. This allows you to magnify photos up to 8X.

1. Turn your camera to **Playback** mode.
2. Use the **Left/Right** navigation buttons to select a photo to magnify.
3. Move the zoom scroll wheel to the Tele position ( **TQ** ) once.
4. Use the zoom scroll wheel to zoom in and out. The zoom indicator and pan box appear on the screen.



5. Use the navigation buttons to pan across the image.
6. Press the  button to return the image to its original scale.



Movie images cannot be enlarged.

## Using the Delete button

The camera is equipped with a quick **Delete** button  for you to delete photos or videoclips without entering the **Playback** menu.

To delete a photo or video:

1. Turn your camera to **Playback** mode.
2. Use the navigation buttons to select the photo/video clip you want to delete.
3. Press the  button. The Delete screen appears.

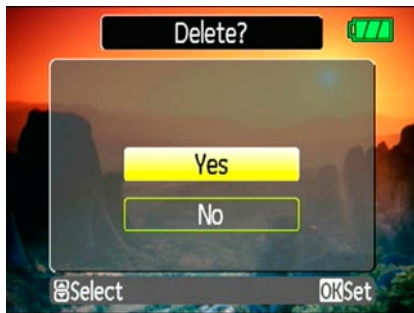

4. Press the **Up/Down** navigation buttons to select **Yes** or **No**. Then press the  button to confirm.



Erased photos/video clips cannot be recovered.



Please refer to page 62 for instructions on the delete menu options.



The  indicator appears if the picture has a sound file attached. You can choose to delete the attached sound file alone or to delete both the picture and the sound file.



# USING THE MENUS

## Still menu

Mode: SCN

In still shooting modes, press the button to enter the Still menu.

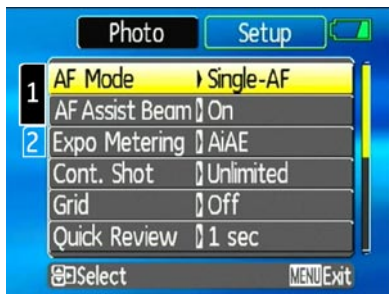

To configure the settings:

1. In the Still menu, press the **Up/Down** button to switch between the page numbers of the function menu, and press the **Right** button to enter the function menu option.
2. Switch between various functions with the **Up/**

**Down** button.

3. Press the **Right** button to enter the sub-menu.
4. Select an option with the **Up/Down** navigational button.
5. Press the button to confirm the setting and exit the menu.

Refer to the following sections for more detailed information on each setting.



## AF mode (Auto-Focus mode)

Use this setting to control the auto-focus mechanism while taking pictures.

Two options are available:

- **Single-AF:** The focus frame appears on the center of the LCD screen to focus on the subject.
- **Multi-AF:** The camera automatically focuses the subject in a wide area to find the focus point.



## AF-assist beam

Use this setting to aid focus in dark conditions. Select **On** to turn on the AF assist beam, or **Off** to disable the function.



## Expo Metering (Exposure Metering)

Use this setting to select an area for the exposure to be obtained.

Three options are available:

- **Spot AE (Spot Auto Exposure)**
- **Center-Weight**
- **AiAE (Artificial Intelligence AE)**



## Cont. Shot (Continuous shot)

Use this setting to perform continuous shooting. Once in this mode, you must continuously hold the shutter button to use this function.

Four options are available:

- **Off:** Capture a single shot only.
- **3 shot:** Capture up to 3 consecutive pictures.
- **Last 3 shots:** Capture pictures continuously until the shutter button is released but only the last 3 shots are recorded.

- **Time-Lapse :** Automatically capture pictures in at predefined intervals.

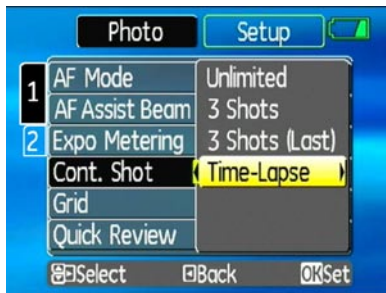

- 📖 The flash is designed not to work in this mode in order to enable quick succession of shots.
- 📖 To activate this mode, the camera must have the self-timer for multiple shots already turned on (as described on page 23)

## Grid

Use this setting to turn on or off the framing grids when taking photos. This may help you position the subject in your composition.



## Quick Review

This setting refers to the quick photo review immediately after taking a picture. The picture stays on the LCD screen for an adjustable period of time.



Four options are available:

- Off
- 1 sec
- 2 sec
- 3 sec

## Digital Zoom

Use this setting to enable or disable the digital zoom function. When disabled, only the optical zoom is enabled.

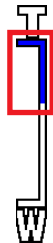

## Digital Zoom indicator

- **Off:** gray color.
- **On:** reddish color.

## Histogram

The histogram is used for checking the exposure while taking pictures. Use this setting to enable or disable the histogram display on the LCD screen.



- Off
- On

## Slow Shutter

In Slow shutter mode, the shutter will remain open as long as the shutter button is pressed. This gives you complete control over the duration of exposure. (The slow shutter mode is available only in **M** manual mode.)



- **Manual** : To set a long exposure time between 2~30 sec.



The use of tripod is recommended for prolonged exposure.

## Blink Detection

The Blink Detection feature is on by default, and after taking each photo, a warning message will pop up if a blink had been detected in the photo.



- Off:
- On

## Date Imprint

Include a date/time stamp in the photo image.



- Off:
- Date
- Date and time

## Movie menu

Mode: 

In movie shooting mode, press the  button to enter the **Movie** menu.



To configure the settings:

1. In the Short Movie Shot menu, press the **Up/Down** button to switch between the page numbers of the function menu, and press the **Right** button to enter the function menu option.
2. Switch between various functions with the **Up/Down** button.
3. Press the **Right** button to enter the sub-menu.
4. Press the  button to confirm the setting and exit the menu.

Refer to the following sections for more detailed information on each setting.

## Expo Metering (Exposure Metering)

Set metering mode for various lighting conditions.



Three options are available:

- Spot metering
- Center-weighted average metering
- Artificial intelligence automatic exposure (Ai AE)



## Playback menu

Mode: 

In playback mode, press the  button to enter the Playback menu.

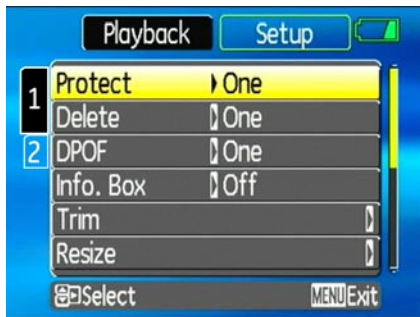

Please refer to the following sections for detailed instructions on the various menu options.



## Protect

To prevent pictures or videos being erased accidentally, you can use this setting to lock one or all files.



To protect/unprotect a picture or video:

1. Switch to playback mode using the mode dial. Use the **Left/Right** buttons to locate and display the photo or movie that you want to protect.
2. Select the **Protect** setting from the **Playback** menu as described previously.

3. Use the **Up/Down** navigation buttons to select **One** to protect this picture/video, or select **All** to protect all pictures/videos in the internal memory or memory card. Then press the **Right** navigation button.
4. Use the  button to select **Yes** to lock the displayed picture/video or **Unlock** to unlock it, and use the **Up/Down** navigation buttons to select **Back** to return to the **Playback** menu.
5. A key () icon will appear on the top of the screen to indicate that the picture/video is protected.
6. Select **reset** to cancel protection for all files that have been placed in the protected mode.

## Delete

There are three ways to delete files: (please note that a file cannot be recovered once it is deleted.)



### • Delete One:

1. On the Delete menu, select **Delete One** and then press the **Right** button.
2. Using the **Left/Right** buttons, locate the photo or movie file to be deleted. Select **Yes** (to delete file) or **No** (to return to the previous menu) using the **Up/Down** buttons, then press the  button to confirm.

- **Delete All:**

1. On the Delete menu, select **Delete All** and then press the **Right** button.
2. Using the **Left/Right** buttons, select **Yes** (to delete all files) or **No** (to cancel and return to the previous menu).



The “” indicator means a file is protected. File protection must be removed first before a file can be deleted.



Deleting files will cause DPOF settings to be reset.

## DPOF (Digital Print Order Format)

DPOF allows you to record your selection of pictures that you would like to print, and will save your selection in the memory card, so that you can simply hand your memory card to a photo kiosk without having to tell them in person which photos you would like to print.



## Info. Box (Information Box)

Use this setting to enable or disable the text display for taking pictures. The following information will be displayed on the screen: histogram display, aperture value, shutter speed, exposure value, image size, image quality, and ISO value. (Please refer to page 35 for information on the menu options shown.)





## Trim

The trim setting allows you select an area of the photo you want to keep and then save it as a new photo.

To trim a picture:

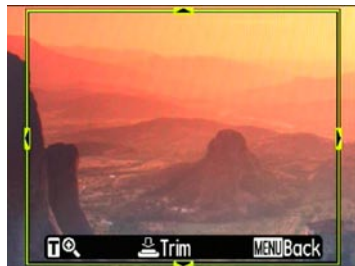
1. Select the **Trim** setting from the **Playback** menu.
2. Using the **Left/Right** buttons, locate the photo that you want to crop and have it displayed on the LCD.
3. Use the zoom scroll wheel and navigation buttons to adjust the trimming box to fit the location and size of the new picture.



4. Press the **Shutter** button to save what you see on the LCD screen as a new picture, or the  button to cancel and return to the **Playback** menu.

## Resize

This setting allows you to resize a picture to a specified resolution, and saves it as a new picture.

1. Select the **Resize** setting from the **Playback** menu as described previously.



2. Use the **Left/Right** navigation buttons to select a picture to resize.
3. Use the **Up/Down** navigation buttons to select a

resolution (**1024X768** or **640X480**) to resize the image or **back** to cancel and return to the **Playback** menu.

4. Press the  button to confirm the setting.

 Resizing an image creates a new file that contains the image in the size you select. The file with the original image also remains in memory.

 If the message “The image cannot be edited.” appears, it means that the current image cannot be resized.

## Rotate

You can use this setting to change the picture orientation of the picture.

1. Select the **Rotate** setting from the **Playback** menu as described previously.
2. Use the **Left/Right** navigation buttons to select a picture to rotate.
3. Use the **Up/Down** navigation buttons to select the

direction for rotation or **Back** to cancel and return to the **Playback** menu.

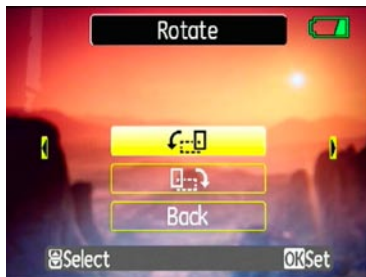

4. Press the  button to confirm the setting.

 The rotated image will be saved as a new file, and the original image will remain intact in memory.

## Slide show

This setting allows you to view all the stored pictures as a slideshow.

1. Select the **Slide show** setting from the **Playback** menu.
2. Use the **Up/Down** navigation buttons to select **Effect**, **Interval time**, or **Repeat** and use the **Left/Right** navigation buttons to adjust the setting.

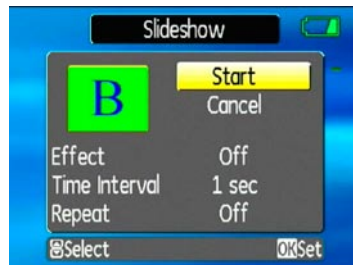

3. Use the **Up/Down** navigation buttons to select **Start** to run the slideshow or **Cancel** to return to the **Playback** menu.
4. Press the  button to confirm the setting.

## Red-eye removal

Use this setting to remove red-eye effect in your photos.

1. Select the **Red-eye removal** setting from the **Playback** menu as described previously.
2. Use the **Left/Right** navigation buttons to select the image for which red-eye will be removed.
3. Use the **Up/Down** navigation buttons to select **Yes** to fix the selected image or **back** to cancel and return to the **Playback** menu.



4. Press the  button to confirm the setting.



For best results, the face of the subject should be relatively large on the LCD screen, the subject should be facing the camera as front on as possible, and the red eyes should be as large as possible.

## Setup menu

Mode: SCN

The **Setup** menu is available in all modes. Press the button in any modes, then use the navigation buttons to select the **Setup** menu.

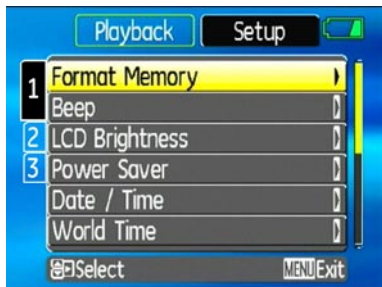

To configure the settings:

1. In the Setting menu, press the **Up/Down** button to switch between the page numbers of the function menu, and press the **Right** button to enter the Setting menu option.

2. Switch between various functions with the **Up/Down** button.
3. Press the **Right** button to enter the sub-menu.

Refer to the following sections for more detailed information on each setting.

### Format Memory

Please note: formatting enables you to delete all contents in the memory card and built-in memory, including protected photo and movie files.

To use this setting:

1. Select the **Format Memory** setting from the **Setup** menu as described previously.
2. Use the **Left/Right** navigation buttons to select **Yes** or **No**, and press the button to confirm.





3. The current media is formatted.

## Beep

Use this setting to adjust the volume of beep when buttons are pressed and change the tones for shutter, buttons, self-timer, and power-on/power-off.

To change this setting:

1. Select the **Beep** setting from the **Setup** menu as described previously.
2. Use the **Up/Down** navigation buttons to switch between volume, shutter tone, key tone, self-timer tone, and power tone fields.



3. Use the **Left/Right** navigation buttons to adjust the volume and change each tone style. Then press the  button to confirm.

## LCD Brightness

Use this setting to adjust the brightness of your LCD screen.

1. Select the **LCD Brightness** setting from the **Setup** menu as described previously.
2. Use the **Up/Down** buttons to select to **Auto** or **Manual** brightness adjustment, and then press  to confirm your election.



3. For manual adjustment, use the **Left/Right** buttons to adjust the brightness.

## Power Saver

This setting allows you to save power and get the maximum possible running time for your battery. Follow the steps below to turn off the LCD screen and camera automatically after a period of inactivity.

1. Select the **Power Save** setting from the **Setup** menu as described previously.
2. Use the **Up/Down** navigation buttons to switch between LCD power and Camera power fields.



3. Use the **Left/Right** navigation buttons to specify the idle period before automatic power-off. The level bars correspond to the following idle periods.
  - LCD off:  
30 seconds, 1 minute, 2 minutes, and Always on.
  - Camera off:  
3 minutes, 5 minutes, 10 minutes, and Always on.
4. Press the  button to confirm.

## Date/Time

See “Setting the Date and Time” section on page 19.

## World time

The world time setting is a useful function on your overseas trips. This feature enables you to display the local time on the LCD screen while you are overseas.

1. Select the **World time** setting from the **Setup** menu as described previously. The world time screen appears.
2. Use the **Up/Down** navigation buttons to switch between the hometown (🏠) and travel destination (➔) fields.
3. Use the **Left/Right** navigation buttons to select a city close to the desired time zone. Then press the  button to confirm.



## File Numbering

After capturing photos or videos, the camera will automatically save the file with a numeric suffix.



|                      |   |
|----------------------|---|
| Select this setting: | Serial number is derived and assigned to a new file as follows:           |
| Continue             | whether the number should continue on from the last photo you have taken  |
| Reset                | reset the counter to 1 and save files in a new folder in the memory card. |

## Language

See “Setting the Language” section on page 20.

## Video system

Use this setting to determine your video system in the current area.

1. Select the **Video system** setting from the **Setup** menu as described previously.
2. Use the **Up/Down** navigation buttons to select **NTSC** or **PAL**. Then press the  button to confirm.

The video output signal can be switched to NTSC or PAL to accommodate different regional standards. The appropriate setting will vary between regions.

**NTSC** : USA, Canada, Taiwan, Japan, etc.

**PAL** : Europe, Asia (excluding Taiwan), Oceania, etc.

**Note** : The TV output will not display properly if an incorrect video system is selected.



## Copy to Card (Copy internal memory to memory card)

Use this setting to copy the files stored in the internal memory to the memory card.

1. Select the **Copy to memory card** setting from the **Setup** menu as described previously.
2. Use the **Up/Down** navigation buttons to select **Yes** or **No**. Then press the  button to confirm.



## Reset Settings

Use this setting to restore the camera to its default settings.

1. Select the **Reset** setting from the **Setup** menu as described previously.
2. Use the **Up/Down** navigation buttons to select **Yes** or **No**. Then press the  button to confirm.



## FW Ver. (Firmware version)

Use this setting to view the current camera firmware version.

1. Select the **FW Ver.** setting from the **Setup** menu as described previously.
2. If SD card contains a new version of firmware, please upgrade accordingly as necessary.



## Connecting to a TV

You can connect your camera to your television, computer, or printer to view picture you have taken.

By using the AV cable, you can view the captured images on a TV. Follow the steps below to connect the supplied AV cable to a TV.

1. Choose [NTSC] or [PAL] to match your TV video standard (see page 72) and then turn off the camera.
2. Connect one end of the AV cable to the USB/AV OUT port on your camera.
3. Connect the plugs on the other end of the cable to the audio and video input ports on the TV.
4. Turn on the camera and the TV on.

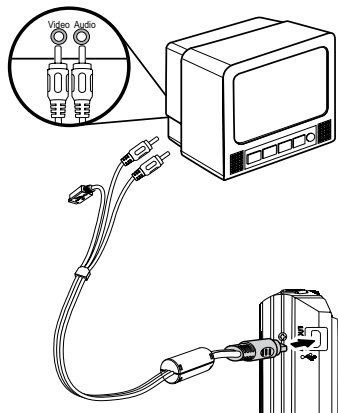

Make sure that both the camera and TV are turned off before connecting the AV cable.





Use a fully charged battery to prevent the camera from turning off unexpectedly while connected.

## Connecting to a PC

Use the USB cable and ArcSoft software (CD-ROM) supplied with your camera to copy (transfer) pictures to a computer.

### Setting the USB mode

Since the camera's USB port can be set to connect with either a PC or a Printer, the following steps will allow you to ensure that the camera is correctly configured to connect with a PC.

1. Press the  button and use the Up/Down navigation buttons to select **USB Connect**, and then press the Right navigation button.
2. Use the Up/Down navigation buttons to select **PC**.
3. Press the  button to confirm the setting.

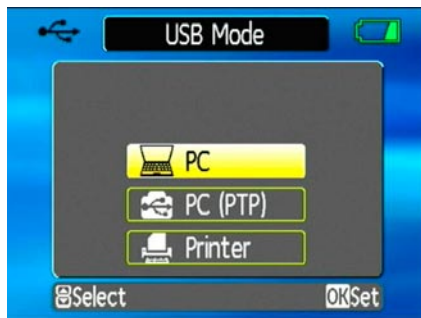

### Transferring files to your PC

The computer will automatically detect the camera as a removable drive. Double-click **My Computer** icon on the desktop to locate the removable drive and to copy the folders and files in the drive to a directory on your PC as you would copy any typical folder or file.



By using the USB cable, you can transfer the captured photos and videos to a PC. Follow the steps below to connect the camera to a PC.

1. Start a computer to which ArcSoft software has been installed.
2. Make sure both the camera and PC are turned on.
3. Connect one end of the supplied USB cable to the USB/AV OUT port on your camera.
4. Connect the other end of the cable to an available USB port on your PC.

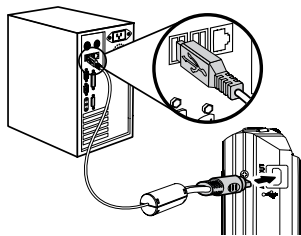

5. Disconnect the camera once transfer is completed.

#### **If the USB option is set to [PC] :**

Turn the camera off and disconnect the USB cable.

#### **If the USB option is set to [PC (PTP)] :**

Remove the camera from the system as described below before turning the camera off and disconnecting the USB cable.

#### **Window XP Home Edition/XP Professional**

Click the [Safely Remove Hardware] icon  in the taskbar and select [Safely remove USB Mass Storage Device] from the menu displayed.



## Window 2000 Professional

Click the [Unplug or Eject Hardware] icon  in the taskbar and select [Stop USB Mass Storage Device] from the menu displayed.

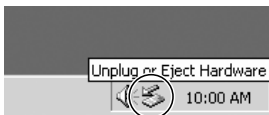

## Macintosh

Drag the untitled icon to the Trash. ("Untitled")



## Connecting to a PictBridge compatible printer





PictBridge allows printing images from a memory card in a digital camera directly to a printer, regardless of brand. To find out if a printer is PictBridge compatible,

simply look for the PictBridge logo on the packaging or check the manual for specifications. With the PictBridge function on your camera, you can print the captured photos directly with a PictBridge compatible printer using the supplied USB cable, without the need for a PC.

### Setting the USB mode

Since the camera's USB port can be set to connect with either a PC or a Printer, the following steps will allow you to ensure that the camera is correctly configured to connect with a Printer.

1. Press the  button and use **Up/Down** to select **USB Connect**, and then press the Right navigation button.
2. Use **Up/Down** to select **Printer**.

3. Press the  button to confirm the setting.

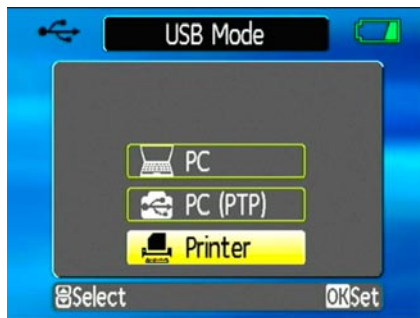

-  Every time the camera is powered off, the USB Mode will automatically revert back to PC mode.

## Connecting the camera and printer.

1. Make sure both the camera and printer are turned on.
2. Connect one end of the supplied USB cable to the USB port on your camera.
3. Connect the other end of the cable to the USB port on the printer.

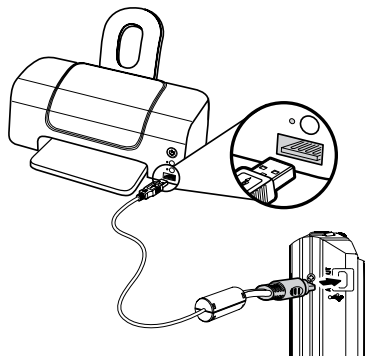

If the camera is not connected to a PictBridge compatible printer, the following error message appears on the LCD screen.



-  The above error message would also appear if the USB mode were set incorrectly, in which case you should disconnect the USB cable, check the USB mode settings, ensure that the Printer is turned on, and then try connecting the USB cable again.

## Using the PictBridge menu

After setting the USB mode to Printer, the **PictBridge** menu appears.

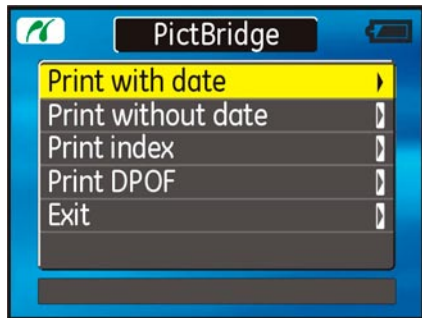

Use the **Up/Down** navigation buttons to select a menu item, and press the **Right** navigation button to enter.

Refer to the following sections for more detailed information on each setting.

### Print with date

If you have set the date and time of your camera, the date record would be saved with the photos you take. You can print the photos with date by following the steps below.

1. Select **Print with date** from the **PictBridge** menu. The following screen appears.



2. Use the **Left/Right** navigation buttons to scroll through the photos.

3. Use the **Up/Down** navigation buttons to select the number of prints for the current displayed photo.
4. Press the  button and the following screen appears.

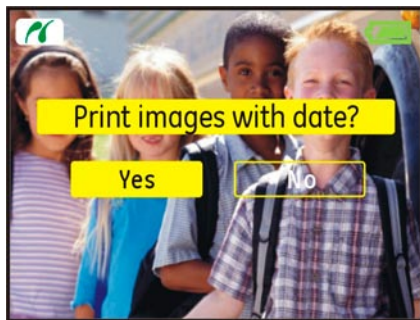



5. Select **Yes** to confirm printing, or **No** to cancel. Then press the  button.

## Print without date

Use this setting to print the photos without dates on them.

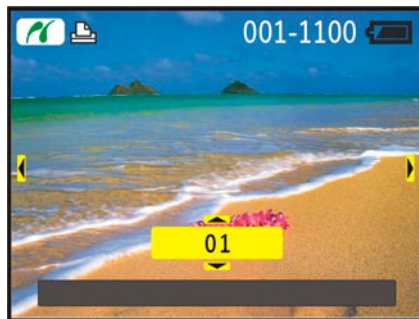
1. Select **Print without date** from the PictBridge menu. The following screen appears.



2. Use the **Left/Right** navigation buttons to scroll through the images.
3. Use the **Up/Down** navigation buttons to select the number of prints for the current displayed image.
4. Press the  button and the following screen appears.

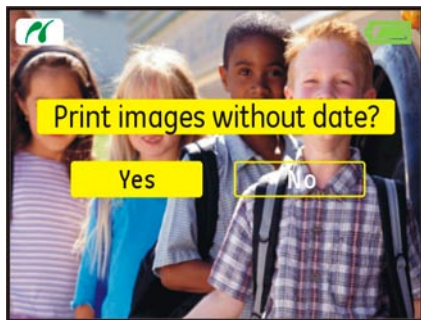

5. Select **Yes** to confirm printing, or **No** to cancel. Then press the  button.



2. Select **Yes** to confirm the printing, or **No** to cancel. Then press the  button.

## Print index

You can use this setting to print all indexes to show all the photos currently in your camera.

1. Select **Print index** from the **PictBridge** menu. The following screen appears.

## Print DPOF (Digital Print Order Format)

To use DPOF printing, you must make the selection of photos for printing using the DPOF settings before hand. See “DPOF” section on page 63.

1. Select **Print DPOF** from the **PictBridge** menu. The following screen appears.



2. Select **Yes** to confirm the printing, or **No** to cancel. Then press the  button.

## Exit

To exit the **PictBridge** menu, select **Exit**. The “Remove USB cable” message will be displayed.



Disconnect the USB cable from the camera and printer.



# APPENDICES

## Specifications : A950/A1050/WM1050/A1250



"Design and specifications are subject to change without notice."

| Model name                    | A950  | A1050                          | WM1050                         | A1250                         |
|-------------------------------|---|--------------------------------|--------------------------------|-------------------------------|
| Effective Image Sensor Pixels | 9.1 Megapixels  | 10.1 Megapixels                | 10.1 Megapixels                | 12.2 Megapixels               |
| Image Sensor                  | 9.4 Megapixels<br>1/2.33" CCD   | 10.4 Megapixels<br>1/2.33" CCD | 10.4 Megapixels<br>1/2.33" CCD | 12.4 Megapixels<br>1/2.3" CCD |
| Lens Focal Length<br>F =      | 6.3mm (Wide) ~ 31.5mm (Tele)  |                                |                                |                               |
| 35mm film<br>equivalent       | 35mm (Wide) ~ 175mm (Tele)  |                                |                                |                               |
| Lens F number                 | F3.0 (Wide) ~ F4.7 (Tele)   |                                |                                |                               |
| Lens Construction             | 9 elements in 7 groups  |                                |                                |                               |
| Optical Zoom                  | 5X  |                                |                                |                               |
| Lens Focusing<br>Range        | Normal: (Wide) 60cm ~∞, (Tele) 80cm ~∞;<br>Macro: (Wide) 5cm ~ 80cm, (Tele) 60cm ~∞ |                                |                                |                               |

| Model name                               | A950  | A1050  | WM1050   | A1250  |
|--|---|--|--|--|
| Anti-Handshake                           | Electronic Image Stabilization                            |  |  |  |
| Digital Zoom                             | 5.7X digital zoom (Combined Zoom: 28.5X)                  |  |  |  |
| Number of Recording Pixels : Still Image | 9MP, 8MP(3:2), 8MP, 7MP(16:9), 5MP, 3MP, 0.3MP            | 10MP, 9MP(3:2), 9MP, 8MP, 7MP(16:9), 5MP, 3MP, 0.3MP | 10MP, 9MP(3:2), 9MP, 8MP, 7MP(16:9), 5MP, 3MP, 0.3MP | 12MP, 10MP(3:2), 10MP, 9MP(16:9), 8MP, 5MP, 3MP, 0.3MP |
| Number of Recording Pixels : Movie       | 640x480pixels: 30fps/15fps,<br>320x240pixels: 30fps/15fps |  |  |  |
| Image Compression                        | Best, Fine, Normal  |  |  |  |
| DCF, DPOF (Ver1.1) Support               | Yes   |  |  |  |
| File Format : Still Image                | Exif 2.2 (JPEG)   |  |  |  |
| File Format : Movie                      | Quick Time Motion JPEG, Audio: G.711 [Monaural]           |  |  |  |
| File Format : Audio                      | WAVE [Monaural] (Max 60 seconds)                          |  |  |  |

| Model name              | A950  | A1050 | WM1050 | A1250 |
|-------------------------|---|-------|--------|-------|
| Shooting Modes          | Auto, Manual, ASCN, Image Stabilization, Movie, Scene (Sport, Children, Indoor, Leaf, Snow, Sunset, Fireworks, Glass, Museum, Landscape, Night Landscape, Night Portrait, Portrait), Panorama |       |        |       |
| Smile Detection         | Yes   |       |        |       |
| Blink Detection         | Yes   |       |        |       |
| Face-Detection          | Yes   |       |        |       |
| Red-eye Removal         | Yes   |       |        |       |
| Pan-Capture Panorama    | Yes   |       |        |       |
| LCD Display             | 2.5 inch LTPS TFT color LCD (230,400 pixels)  |       |        |       |
| ISO Sensitivity         | Auto, ISO 64/100/200/400/800/1600   |       |        |       |
| AF Method               | Single AF, Multi-AF (TTL 9-point), Face-Detection, AF Assist Light (On/Off)   |       |        |       |
| Light Metering Method   | Artificial Intelligence AE (Ai AE), Center-weighted Average, Spot (Fixed to center of frame)  |       |        |       |
| Exposure Control Method | ProgramAE (AE-lock available)   |       |        |       |

| Model name                         | A950  | A1050                                 | WM1050                                | A1250                                 |
|------------------------------------|---|---------------------------------------|---------------------------------------|---------------------------------------|
| Exposure Compensation              | ±2 EV in 1/3 steps  |                                       |                                       |                                       |
| Shutter Speed                      | 4 ~ 1/2000 second (Manual 30 seconds)   |                                       |                                       |                                       |
| Continuous Shooting                | Approx. 1.65 fps<br>(Large/Fine mode)   | Approx. 1.65 fps<br>(Large/Fine mode) | Approx. 1.65 fps<br>(Large/Fine mode) | Approx. 1.39 fps<br>(Large/Fine mode) |
| Playback Modes                     | Single Photo, Index (4/9/16 thumbnails), Slide Show, Movie (Slow-Motion possible), Zoom (Approx. 2X~8X), Audio, Histogram Display |                                       |                                       |                                       |
| White Balance Control              | Auto (AWB), Daylight, Cloudy, Fluorescent, Fluorescent CWF, Incandescent, Manual  |                                       |                                       |                                       |
| Internal Flash<br>(Shooting Range) | Auto/Red-Eye Reduction/Forced Flash/No Flash/Slow Synchro/Red-Eye Reduction+Slow Synchro  |                                       |                                       |                                       |
|                                    | Gno. 5.3 (ISO 100)  |                                       |                                       |                                       |
|                                    | (Shooting Range): (Wide) : Approx. 0.3m~4.9m<br>(Tele) : Approx. 0.3m~3.1m (ISO 800)  |                                       |                                       |                                       |

| Model name                                   | A950  | A1050 | WM1050 | A1250 |
|--|---|-------|--------|-------|
| Jacks  | USB2.0/AV-OUT (Integrated Proprietary Connector)                                |       |        |       |
| Recording Media                              | Internal Memory: 24MB   |       |        |       |
|  | SD Card/SDHC Card (Up to 8GB support)   |       |        |       |
| Other Features                               | PictBridge, Exif Print Support, Multi-language Support (31 languages)           |       |        |       |
| Power  | 2 x AA Alkaline Battery, AA NiMH Battery [Not Included]                         |       |        |       |
| Shooting Capability<br>(Battery Performance) | AA Alkaline Batteries: Approx. 150 (A1250: 140) shots (based on CIPA standards) |       |        |       |
|  | AA NiMH Battery : Approx. 400 shots (CIPA Standards)                            |       |        |       |
| Operation Environment                        | Temperature: 0~40 <sup>0</sup> C, Humidity: 0~90%                               |       |        |       |
| Dimensions (W x H x D)                       | 92.4mm x 61mm x (24.1 ~ 25.9)mm   |       |        |       |
| Mass   | Approx. 145g (without the battery)  |       |        |       |

## Specifications : A1035/A1235



"Design and specifications are subject to change without notice."

| Model name                    | A1035   | A1235                      |
|-------------------------------|---|----------------------------|
| Effective Image Sensor Pixels | 10.1 Megapixels   | 12.2 Megapixels            |
| Image Sensor                  | 10.4 Megapixels 1/2.33" CCD   | 12.4 Megapixels 1/2.3" CCD |
| Lens Focal Length F =         | 6.3mm (Wide) ~ 18.9mm (Tele)  |                            |
| 35mm film equivalent          | 35mm (Wide) ~ 105mm (Tele)  |                            |
| Lens F number                 | F3.0 (Wide) ~ F4.0 (Tele)   |                            |
| Lens Construction             | 9 elements in 7 groups  |                            |
| Optical Zoom                  | 3X  |                            |
| Lens Focusing Range           | Normal: (Wide) 60cm ~∞, (Tele) 80cm ~∞;<br>Macro: (Wide) 5cm ~ 80cm, (Tele) 60cm ~∞ |                            |
| Anti-Handshake                | Electronic Image Stabilization  |                            |
| Digital Zoom                  | 5.7X digital zoom (Combined Zoom: 17.1X)  |                            |

| Model name                               | A1035   | A1235  |
|--|---|--|
| Number of Recording Pixels : Still Image | 10MP, 9MP(3:2), 9MP, 8MP, 7MP(16:9), 5MP, 3MP, 0.3MP  | 12MP, 10MP(3:2), 10MP, 9MP(16:9), 8MP, 5MP, 3MP, 0.3MP |
| Number of Re-cording Pixels :Movie       | 640x480pixels: 30fps/15fps,<br>320x240pixels: 30fps/15fps   |  |
| Image Compression                        | Best, Fine, Normal  |  |
| DCF, DPOF (Ver1.1) Support               | Yes   |  |
| File Format : Still Image                | Exif 2.2 (JPEG)   |  |
| File Format : Movie                      | Quick Time Motion JPEG, Audio: G.711 [Monaural]   |  |
| File Format : Audio                      | WAVE [Monaural] (Max 60 seconds)  |  |
| Shooting Modes                           | Auto, Manual, ASCN, Image Stabilization, Movie, Scene (Sport, Children, Indoor, Leaf, Snow, Sunset, Fireworks, Glass, Museum, Landscape, Night Landscape, Night Portrait, Portrait), Panorama |  |
| Smile Detection                          | Yes   |  |
| Blink Detection                          | Yes   |  |
| Face-Detection                           | Yes   |  |

| Model name              | A1035   | A1235                              |
|-------------------------|---|------------------------------------|
| Red-eye Removal         | Yes   |                                    |
| Pan-Capture Panorama    | Yes   |                                    |
| LCD Display             | 2.5 inch LTPS TFT color LCD (230,400 pixels)  |                                    |
| ISO Sensitivity         | Auto, ISO 64/100/200/400/800/1600   |                                    |
| AF Method               | Single AF, Multi-AF (TTL 9-point), Face-Detection, AF Assist Light (On/Off)   |                                    |
| Light Metering Method   | Artificial Intelligence AE (Ai AE), Center-weighted Average, Spot (Fixed to center of frame)                                      |                                    |
| Exposure Control Method | ProgramAE (AE-lock available)   |                                    |
| Exposure Compensation   | ±2 EV in 1/3 steps  |                                    |
| Shutter Speed           | 4 ~ 1/2000 second (Manual 30 seconds)   |                                    |
| Continuous Shooting     | Approx. 1.65 fps (Large/Fine mode)  | Approx. 1.39 fps (Large/Fine mode) |
| Playback Modes          | Single Photo, Index (4/9/16 thumbnails), Slide Show, Movie (Slow-Motion possible), Zoom (Approx. 2X~8X), Audio, Histogram Display |                                    |
| White Balance Control   | Auto (AWB), Daylight, Cloudy, Fluorescent, Fluorescent CWF, Incandescent, Manual  |                                    |



| Model name                                | A1035  | A1235  |
|---|--|--|
| Internal Flash (Shooting Range)           | Auto/Red-Eye Reduction/Forced Flash/No Flash/Slow Synchro/Red-Eye Reduction+Slow Synchro |  |
|   | Gno. 5.3 (ISO 100)   |  |
|   | (Shooting Range): (Wide) : Approx. 0.3m~4.9m, (Tele) : Approx. 0.3m~3.1m (ISO 800)       |  |
| Jacks                                     | USB2.0/AV-OUT (Integrated Proprietary Connector)   |  |
| Recording Media                           | Internal Memory: 24MB  |  |
|   | SD Card/SDHC Card (Up to 8GB support)  |  |
| Other Features                            | PictBridge, Exif Print Support, Multi-language Support (31 languages)                    |  |
| Power                                     | 2 x AA Alkaline Battery, AA NiMH Battery [Not Included]                                  |  |
| Shooting Capability (Battery Performance) | AA Alkaline Batteries: Approx. 150 shots (based on CIPA standards)                       | AA Alkaline Batteries: Approx. 140 shots (based on CIPA standards) |
|   | AA NiMH Battery : Approx. 400 shots (CIPA Standards)                                     |  |
| Operation Environment                     | Temperature: 0~40 <sup>o</sup> C, Humidity: 0~90%  |  |
| Dimensions (W x H x D)                    | 92.4mm x 61mm x (24.1 ~ 25.9)mm  |  |
| Mass                                      | Approx. 145g (without the battery)   |  |

# APPENDICES

## Specifications : E1255W



"Design and specifications are subject to change without notice."

|                               |                      |  |
|-------------------------------|----------------------|--|
| Effective Image Sensor Pixels |                      | 12.2 Megapixels  |
| Image Sensor                  |                      | 12.4 Megapixels [1/2.3" (CCD)]   |
| Lens                          | Focal Length F =     | 5.2mm (Wide) ~ 26mm (Tele)   |
|                               | 35mm film equivalent | 28mm (Wide) ~ 140mm (Tele)   |
|                               | F number             | F3.3 (Wide) ~ F5.2 (Tele)  |
|                               | Construction         | 9 elements in 8 groups   |
|                               | Optical Zoom         | 5X   |
|                               | Focusing Range       | Normal: (Wide) 60cm ~ ∞, (Tele) 120cm ~ ∞;<br>Macro: (Wide) 5cm ~ 80cm, (Tele) 120cm ~ ∞ |
| Anti-Handshake                |                      | Electronic Image Stabilization   |
| Digital Zoom                  |                      | 4.5X digital zoom (Combined Zoom: 22.5X)   |

|                            |             |   |
|----------------------------|-------------|---|
| Number of Recording Pixels | Still Image | 12MP, 10.5MP(3:2), 10MP, 9MP(16:9), 8MP, 5MP, 3MP, 2MP, 0.3MP   |
|                            | Movie       | 640x480pixels: 30fps/15fps, 320x240pixels: 30fps/15fps  |
| Image Compression          |             | Best, Fine, Normal  |
| DCF, DPOF (Ver1.1) Support |             | Yes   |
| File Format                | Still Image | Exif 2.2 (JPEG)   |
|                            | Movie       | AVI (Image Compression: MPEG4, Audio: G.711 [Monaural])   |
|                            | Audio       | WAVE [Monaural] (Max 60 seconds)  |
| Shooting Modes             |             | Auto, Manual, ASCN, Image Stabilization, Movie, Scene (Sport, Children, Indoor, Leaf, Snow, Sunset, Fireworks, Glass, Museum, Landscape, Night Landscape, Night Portrait, Portrait), Panorama |
| Smile Detection            |             | Yes   |
| Blink Detection            |             | Yes   |
| Face-Detection             |             | Yes   |
| Red-eye Removal            |             | Yes   |

|                         |   |
|-------------------------|---|
| Pan-Capture Panorama    | Yes   |
| LCD Display             | 3.0 inch (230,400 pixels) LTPS (low-temperature polycrystalline silicon) TFT color LCD  |
| ISO Sensitivity         | Auto, ISO 64/100/200/400/800/1600   |
| AF Method               | Single AF, Multi-AF (TTL 9-point), AF Assist Light (On/Off)   |
| Light Metering Method   | Artificial Intelligence AE (Ai AE), Center-weighted Average, Spot (Fixed to center of frame)                                      |
| Exposure Control Method | ProgramAE (AE-lock available)   |
| Exposure Compensation   | ±2 EV in 1/3 Step increments  |
| Shutter Speed           | 4 ~ 1/2000 second (Manual 30 s)   |
| Continuous Shooting     | Approx. 1.39 fps (Large/Fine mode)  |
| Playback Modes          | Single Photo, Index (4/9/16 thumbnails), Slide Show, Movie (Slow-Motion possible), Zoom (Approx. 2X~8X), Audio, Histogram Display |
| White Balance Control   | Auto (AWB), Daylight, Cloudy, Fluorescent , Fluorescent CWF, Incandescent, Manual   |

|   |  |
|---|--|
| Internal Flash (Shooting Range)           | Auto/Red-Eye Reduction/Forced Flash/No Flash/Slow Synchro/Red-Eye Reduction+Slow Synchro |
|   | Gno. 5.0 EV (ISO 100)  |
|   | Shooting Range Wide: Approx. 0.6m~3.2m / Tele: Approx. 1.2m ~ 2.0m (ISO 400)             |
| Recording Media                           | Internal Memory: 24MB  |
|   | SD Card/SDHC Card (Up to 8GB support)  |
| Other Features                            | PictBridge, ExifPrint Support, Multi-language Support (31 languages)                     |
| Jacks                                     | USB2.0/AV-OUT (Integrated Proprietary Connector)   |
| Power                                     | Rechargeable Lithium-ion Battery DS5370, 3.7V 700mAh                                     |
| Shooting Capability (Battery Performance) | Approx. 200 shots (based on CIPA standards)  |
| Operation Environment                     | Temperature: 0~40 <sup>0</sup> C, Humidity: 0~90%  |
| Dimensions (W x H x D)                    | 92mm x 58mm x (19.5 ~ 22.5)mm  |
| Mass                                      | Approx. 145g (Body only)   |

## Error messages

| Messages              | Explanation   |
|-----------------------|---|
| No card               | <ul style="list-style-type: none"><li>• The memory card is not inserted.</li></ul>  |
| Card error            | <ul style="list-style-type: none"><li>• The memory card is not formatted.</li></ul>   |
| Card full             | <ul style="list-style-type: none"><li>• The memory card is full and cannot store any new images.</li></ul>                      |
| Write protect         | <ul style="list-style-type: none"><li>• The memory card is write-protected.</li></ul>   |
| Picture error         | <ul style="list-style-type: none"><li>• The picture is not captured correctly.</li><li>• The picture is damaged.</li></ul>      |
| No picture            | <ul style="list-style-type: none"><li>• There are no images in the memory card or in the internal memory.</li></ul>             |
| Lens error            | <ul style="list-style-type: none"><li>• The lens is probably stuck and the camera will power off automatically.</li></ul>       |
| System error          | <ul style="list-style-type: none"><li>• Unexpected error encountered.</li></ul>   |
| No sound file         | <ul style="list-style-type: none"><li>• There are no audio files in the memory card or in the internal memory.</li></ul>        |
| Image cannot be saved | <ul style="list-style-type: none"><li>• The write protection switch in the memory card is set to the "LOCK" position.</li></ul> |

| Messages                                 | Explanation  |
|--|--|
| Card is not formatted, format?           | <ul style="list-style-type: none"> <li>• Confirm whether the memory card should be formatted.</li> </ul>   |
| This image cannot be deleted             | <ul style="list-style-type: none"> <li>• The picture or video you are trying to delete is protected.</li> </ul>  |
| Cannot record movie                      | <ul style="list-style-type: none"> <li>• The write protection switch in the memory card is set to the "LOCK" position.</li> </ul>                          |
| Sound file cannot be saved               | <ul style="list-style-type: none"> <li>• The write protection switch in the memory card is set to the "LOCK" position.</li> </ul>                          |
| Warning!! Camera recording, please wait. | <ul style="list-style-type: none"> <li>• No other actions allowed to perform during video/audio recording.</li> </ul>                                      |
| Warning!! Battery exhausted.             | <ul style="list-style-type: none"> <li>• The battery is out of charge.</li> </ul>  |
| This file cannot be played back          | <ul style="list-style-type: none"> <li>• The picture format cannot be recognized by the camera.</li> </ul>   |
| No connection                            | <ul style="list-style-type: none"> <li>• The camera is not connected to the printer correctly.</li> </ul>  |
| Print error                              | <ul style="list-style-type: none"> <li>• There is a problem with camera or printer.</li> </ul>   |
| Cannot print                             | <ul style="list-style-type: none"> <li>• Check that the printer is out of paper or out of ink.</li> <li>• Check if the printer has a paper jam.</li> </ul> |

## Troubleshooting

| Problem   | Possible causes  | Solution  |
|---|--|---|
| Camera does not turn on.                              | <ul style="list-style-type: none"><li>• The battery has run out.</li><li>• The battery is not inserted correctly.</li></ul>  | <ul style="list-style-type: none"><li>• Charge the battery or replace with a fully charged battery.</li><li>• Re-insert the battery observing the correct polarity.</li></ul> |
| Camera turns off suddenly during operation.           | <ul style="list-style-type: none"><li>• The battery has run out.</li></ul>   | <ul style="list-style-type: none"><li>• Charge the battery or replace with a fully charged battery.</li></ul>   |
| The picture is blurred.                               | <ul style="list-style-type: none"><li>• The lens is dirty.</li><li>•  appears when taking pictures.</li></ul> | <ul style="list-style-type: none"><li>• Use a soft cloth to clean the lens on your camera</li><li>• Use the <b>Image Stabilization</b> mode.</li></ul>                        |
| Images, video clips, and audio files cannot be saved. | <ul style="list-style-type: none"><li>• The memory card is full.</li></ul>   | <ul style="list-style-type: none"><li>• Replace the memory card with a new one.</li><li>• Delete unwanted images.</li><li>• Unlock the memory card.</li></ul>                 |



| Problem   | Possible causes  | Solution   |
|---|--|--|
| No picture is taken when pressing the shutter button. | <ul style="list-style-type: none"> <li>• The memory card is full.</li> <li>• No available space to store the files.</li> <li>• The mode dial is in <b>Playback</b> mode.</li> </ul>  | <ul style="list-style-type: none"> <li>• Replace the memory card with a new one or clean off current memory card.</li> <li>• Delete unwanted images.</li> <li>• The memory card is locked.</li> <li>• Turn the mode dial to any still shooting mode.</li> </ul>                              |
| Images cannot print from the connected printer.       | <ul style="list-style-type: none"> <li>• The camera is not connected to the printer correctly.</li> <li>• The printer is not PictBridge compatible.</li> <li>• The printer is out of paper or out of ink.</li> <li>• The paper is jammed.</li> </ul> | <ul style="list-style-type: none"> <li>• Check the connection between the camera and printer.</li> <li>• Use a PictBridge compatible printer.</li> <li>• Load some paper in the printer.</li> <li>• Replace the ink cartridge in the printer.</li> <li>• Remove the jammed paper.</li> </ul> |

<http://www.ge.com/digitalcameras>

